

~~CONFIDENTIAL~~

DEPARTMENT OF THE ARMY TECHNICAL MANUAL

DEPARTMENT OF THE NAVY

DEPARTMENT OF THE AIR FORCE

MARINE CORPS PUBLICATIONS

TM 23-200

OPNAV INSTRUCTION 03400.1B

AFL 136-1

NAVMC 1104 REV

CAPABILITIES OF ATOMIC WEAPONS (U)



Prepared by
Armed Forces Special Weapons Project

DEPARTMENTS OF THE ARMY, THE NAVY
AND THE AIR FORCE

REVISED EDITION NOVEMBER 1957

~~CONFIDENTIAL~~

WARNING NOTICES

Authority for release of this document to a foreign government must be secured from the Assistant Chief of Staff, Intelligence, Headquarters, Department of the Army.

When this document is released to a foreign government, it is released subject to the following conditions: This information is furnished with the understanding that it will not be released to another nation without specific approval of the United States of America, Department of the Army; that it will not be used for other than military purposes; that individual or corporation rights originating in the information whether patented or not will be respected, and that the information will be afforded substantially the same degree of security as afforded by the United States of America, Department of the Army.

This document contains information affecting the national defense of the United States within the meaning of the Espionage Laws, Title 18 U. S. Sections 793 and 794. The transmission or the revelation of its contents in any manner to an unauthorized person is prohibited by law.

~~CONFIDENTIAL~~

Department of the Army Technical Manual
Department of the Navy
Department of the Air Force Manual
Marine Corps Publications

C 1, TM 23-200
OPNAV Instruction 03400.1B, CH-1
AFM 136-1A
NAVMC 1104 REV, CH-1

Capabilities of Atomic Weapons (U)

CHANGES
No. 1

DEPARTMENTS OF THE ARMY, THE NAVY,
AND THE AIR FORCE
WASHINGTON 25, D.C., 24 June 1960

TM 23-200/OPNAV Instruction 03400.1B/AFM 136-1/NAVMC 1104 REV, 29 November 1957,
is changed as follows:

1. Change the Air Force number to read:
AFM 136-1.
2. Remove pages v and vi and substitute pages v and vi of Changes Number One.
3. Remove pages xv through xxii and substitute pages xv through xxii of Changes Number One.
4. Remove pages 2-15 through 2-18 and substitute pages 2-15 through 2-18 of Changes Number One.
5. Remove pages 4-1 through 4-8 and substitute pages 4-1 through 4-8 of Changes Number One.
6. Following page 4-16, add pages 4-16a through 4-16d of Changes Number One.
7. Remove pages 4-21 through 4-24 and substitute pages 4-21, 4-22, 4-22a through 4-22d, 4-23, and 4-24 of Changes Number One.
8. Remove pages 9-3 and 9-4 and substitute pages 9-3 and 9-4 of Changes Number One.
9. Remove pages 9-9 through 9-12 and substitute pages 9-9 through 9-12 of Changes Number One.
10. Remove pages I-7 and I-8 and substitute pages I-7 and I-8 of Changes Number One.
11. Remove pages I-29 through I-32 and substitute pages I-29 through I-32 of Changes Number One.
12. Remove pages II-3 and II-4 and substitute pages II-3 and II-4 of Changes Number One.
13. Remove pages 1, 2, 5 through 8, and 11 and substitute pages 1, 2, 5 through 8, 11 and 12 of Changes Number One.

~~CONFIDENTIAL~~

PAGE LOCATOR FOR PHYSICAL PHENOMENA FIGURES AND TABLES*

	Free air	Air	Transition	Land surface	Water surface	Underground	Underwater
BLAST AND SHOCK:							
Altitude Effects.....	2-9; I-29, 30.	I-29, 30	I-29, 30	I-29, 30	I-29, 30		
Base Surge.....						2-86	2-94
Crater:							
Depth.....			2-65, 72	2-65, 72	2-78	2-65, 72	2-78
Lip.....			2-50	2-50	2-80	2-50	2-80
Profile.....			2-50	2-50		2-50	
Radius (Diameter).....			2-63, 68	2-63, 68	2-76	2-63, 68	2-76
Dynamic Pressure:							
Impulse.....	I-19						
Peak vs. Distance.....	2-21	2-40, 41	2-40, 41	2-40, 41	2-40		
Versus Time.....	2-1; I-16, 21.	2-1	2-1	2-1	2-1		
Wave Forms.....	I-5	I-5	I-5	I-5	I-5		
Ground Shock.....		2-83	2-83	2-53, 83			
Mach Stem.....		2-4, 23	2-4, 23				
Overpressure:							
Effect of Rain or Fog.....	2-43	2-43	2-43	2-43	2-43		
Impulse.....	I-13	I-24	I-24	I-24	I-24		
Peak vs. Distance.....	2-17	2-30, 32	2-30, 32	2-30, 32; I-32	2-30, I-32	2-47	2-47
Versus Time.....	2-1; I-15, 16.	2-1	2-1	2-1	2-1		
Wave Forms.....	I-3	I-3, 27	I-3, 27	I-3, 27	I-3		
Positive Phase:							
Duration.....	2-19	2-36	2-36	2-36	2-36		
Effect of Cut-Off.....							2-56, 57
Precursor.....		2-45	2-12, 45	2-45			
Relations of Various Parameters.....	2-3; I-11	I-11	I-11				
Time of Arrival.....	2-15	2-26	2-26	2-26	2-26		
Velocity:							
Peak Particle.....	2-3; I-10						
Shock.....	I-9						
Water Shock.....							2-59, 89
Water Waves.....					2-91		2-91
THERMAL:							
Atmospheric Transmissivity.....	3-14	3-14	3-14	3-14	3-14		
Fireball.....	3-5	3-5					
Generalized Pulse and Percent Emitted.....	3-7; 6-15	3-7; 6-15	3-7; 6-15	3-7; 6-15	3-7; 6-15		
Radiant Exposure.....	3-12, 18	3-18	3-18	3-18	3-18		
Times.....	3-10	3-10	3-10	3-10	3-10		
Yield vs. Altitude.....	3-12						
NUCLEAR:							
Cloud:							
Diameter.....	4-84	4-84	4-84	4-84	4-84	4-84	4-84
Height.....	4-81, 83	4-81, 83	4-81, 83	4-81, 83	4-81, 83	4-81, 83	4-81, 83
Penetration Dose.....	4-87	4-87	4-87	4-87	4-87	4-87	4-87
Initial Gamma:							
Dose vs. Distance.....	4-14, 15, 16, 16a, 16b, 16c, 16d.	4-14, 15, 16, 16a, 16b, 16c, 16d.	4-10, 11, 12, 13.	4-10, 11, 12, 13.	4-10, 11, 12, 13.	4-19	4-19
Percent vs. Time.....	4-20	4-20	4-20	4-20	4-20		
Shielding (Transmission) Factors.....	6-11; 6-19.	6-11; 6-19.	6-11; 6-19.	6-11; 6-19.	6-11; 6-19.	6-11; 6-19.	6-11; 6-19.

*Page numbers in italics are for tables.

PAGE LOCATOR FOR PHYSICAL PHENOMENA FIGURES AND TABLES*—Continued

	Free air	Air	Transition	Land surface	Water surface	Underground	Underwater
NUCLEAR—Continued							
Neutron:							
Dose, Fission Weapons.....	4-22a, 22b, 22c, 22d, 23.	4-22a, 22b, 22c, 22d, 23.	4-22a, 22b, 22c, 22d, 23.	4-22a, 22b, 22c, 22d, 23.	4-22a, 22b, 22c, 22d, 23.		
Dose, Thermonuclear Weapons.....	4-25	4-25	4-25	4-25	4-25		
Flux.....	12-9	12-9	12-9	12-9	12-9		
Induced Activity.....			4-66; 4-70, 73, 75, 76, 77, 78.				
Transmission Factors.....	6-11	6-11	6-11	6-11	6-11		
Fall-Out:							
Contours.....			4-38, 40, 42, 44, 46, 48.	4-29, 38, 40, 42, 44, 46.	4-38, 40, 42, 44, 46.	4-53, 54, 55, 56, 57.	4-59
Gamma Decay.....			4-35	4-35	4-35	4-35	4-35
Shielding (Transmission) Factors.....			6-11; 6-20.	6-11; 6-20.	6-11; 6-20.	6-11; 6-20.	6-11; 6-20.
Total Dose.....			4-61, 63	4-61, 63	4-61, 63	4-61, 63	4-61, 63
GENERAL:							
Atmospheric Conditions.....	11-3, 4; II-9, 10.	11-3, 4; II-9, 10.	11-3, 4; II-9, 10.	11-3, 4; II-9, 10.	11-3, 4; II-9, 10.		
Comparison of Phenomena.....		5-13, 18	5-13, 18	5-13, 18	5-13, 18		
Relative Air Density.....	4-2; II-9	4-2; II-9	4-2; II-9	4-2; II-9	4-2; II-9		
Water Vapor Density.....	II-10	II-10	II-10	II-10	II-10		

PAGE LOCATOR FOR DAMAGE FIGURES AND TABLES*

	Blast	Thermal	Nuclear
Aircraft.....	9-5, 7, 9, 11	9-11	
Clothing.....		12-3	
Earth-Covered Structures.....	7-4, 8; 7-40, 42, 46		
Electronics Equipment.....	10-15		
Engineer Equipment.....	10-21, 23		
Field Fortifications.....	7-9; 7-53, 54, 55		
Forests.....	11-2; 11-7, 8, 9, 10, 11, 12	11-3, 4; 11-15	
Land Mines.....	10-4		
Materials.....		12-3; 12-5, 10	
Ordnance Equipment.....	10-2		
Personnel.....	6-3; 6-13, 17	6-4, 5; 6-14, 15, 17	6-7, 11; 6-17, 19, 20
Railroad Equipment.....	10-17, 19		
Submarines.....	8-2; 8-10, 11		
Supply Dumps.....	10-13		
Surface Ships.....	8-2; 8-6, 7, 8		
Surface Structures:			
Bridges.....	7-4; 7-34, 36, 38, 46		
Buildings.....	7-3, 4; 7-14, 16, 18, 20, 22, 26, 28, 30, 32, 45, 46		
Oil Tanks.....	7-3; 7-24, 45		
Tanks and Artillery.....	10-11		
Tunnels.....	7-51		
Underwater Mines.....	8-13, 14, 15		
Urban Areas.....		12-1; 12-5, 6, 7	
Vehicles.....	10-9		
Subsurface burst damage distance reduction for surface targets.....	7-49		

*Page numbers in italics are for tables.

CAPABILITIES OF ATOMIC WEAPONS

CHANGES
No. 2

DEPARTMENTS OF THE ARMY, THE NAVY
AND THE AIR FORCE
WASHINGTON 25, D.C., 3 October 1960

TM 23-200/OPNAV Instruction 03400.1B/AFM 136-1/NAVMC 1104, REV, 29 November 1957,
is changed as follows:

1. Make the following pen and ink changes in Changes No. 1:

a. *Page (I)*. Change item 11 to read: Remove pages I-29 and I-30 and substitute pages I-29 through I-32 Changes No. One.

b. *Page (IV)*. Change Navy distribution to read:

F9 (Station CNO)

H23 (AV Med Ctr)

c. *Page v*. Change column 1, line 15 to read: 4-22a through 4-22d..... Change 1

4-23 and 4-24..... Change 1

Change column 1, line 16 to read: 4-25 through 4-88..... Original

Change column 2, line 9 to read: I-9 through I-28..... Original

d. *Index*. Change page numbers 9 and 10 to read 11 and 12, respectively. Add C 1, 24 June 1960, in the upper inside corners of pages 1, 2, 5 through 8, and renumbered pages 11 and 12.

2. Destroy, according to proper security procedures, the page of the Index issued in Changes No. 1 as page 12. The reverse of page 12 is blank.

3. After necessary action, file the transmittal sheet in the front of the manual for reference.

[AG 461 (9 Aug 60)]

BY ORDER OF THE SECRETARIES OF THE ARMY, THE NAVY, AND THE AIR FORCE:

OFFICIAL:

R. V. LEE,
*Major General, United States Army,
The Adjutant General.*

G. H. DECKER,
*General, United States Army,
Chief of Staff.*

G. R. DONAHO,
*Rear Admiral, United States Navy,
Assistant Vice Chief of Naval Operations,
Director of Naval Administration.*

OFFICIAL:

J. L. TARR,
*Colonel, United States Air Force,
Director of Administrative Services.*

THOMAS D. WHITE,
Chief of Staff, United States Air Force.

F. L. WIESEMAN,
*Major General, U.S. Marine Corps,
Deputy Chief of Staff (Plans).*

This publication supersedes TM 23-200/OPNAV INSTRUCTION 003400.1A/AFL 136-4/NAVMC 1104, 1 June 1955, including C 1, 1 April 1956; C 2, 17 October 1956; and C 3, 19 September 1957

PART ONE

PHYSICAL PHENOMENA

SECTION I

INTRODUCTION

1.1 Explosion of a Nuclear Weapon

a. General. An explosion is defined as the sudden release of a large amount of energy in a small space. For high explosives, this energy manifests itself primarily as blast energy, regardless of environmental conditions. In a nuclear explosion, on the other hand, the energy manifests itself in the form of blast, thermal radiation, and nuclear radiation. In addition, the energy released from a nuclear detonation is essentially from a point source, whereas a comparable amount of energy released from a high explosive detonation would require an enormous volume of explosive. Further, the energy released in a nuclear detonation results from a fission process, a fusion process or a combination of the two, while the energy released in a high explosive detonation results from a chemical process which does not affect the nuclei of the atoms involved. In the fission process, heavy atoms are split into pairs of lighter radioactive atoms, whereas in the fusion process two light atoms are combined to form a heavier atom. In both processes, there is a net loss of mass which appears as energy, and there is also an emission of neutrons and gamma rays. The high temperatures resulting from either of these processes in turn cause large pressures to develop, hence rapid expansion and the creation of a shock wave.

b. Energy Partition. Energy partition is defined as the distribution of the total energy released by a nuclear detonation among nuclear radiation, thermal radiation, and blast. Energy partition depends primarily upon environmental conditions, i. e., whether the detonation takes place in air, underground, or underwater. Furthermore,

energy partition has meaning only when related to a particular time after detonation. For example, the energy partition of a nuclear detonation in free air under ambient conditions varying from a homogeneous sea level atmosphere to the conditions existing at 50,000 feet altitude is in the proportion of about 50 percent blast, 35 percent thermal, and 15 percent nuclear (5 percent initial radiations, 10 percent in fission products), if evaluated within the first minute. The energy partition of an underground burst, on the other hand, is entirely different. There is a reduction of thermal radiation received at a distance due to the amount of heat used in vaporizing the surrounding soil and a reduction of air blast due to the amount of blast energy used to produce cratering and ground shock.

1.2 Weapon Ratings

a. In order to provide a yardstick for rating the total energy release of a nuclear detonation, it has become the practice to express the total yield of a nuclear device in terms of a TNT energy equivalent. For example, if the total energy of the blast, thermal radiation, and nuclear radiation released by a nuclear weapon is the same as the energy released by the detonation of 1,000 tons of TNT, the nuclear weapon is rated as a 1,000-ton, or 1-kiloton, weapon. When 1 kilogram of U-235 or plutonium undergoes fission nearly one gram (1/450 pound) of matter is converted into energy. This energy expressed in terms of TNT energy equivalence would be the same as for the detonation of 20,000 tons of TNT. Similarly, the fusion of 1 kilogram of deuterium results in the

transformation of 2.65 grams of matter into energy, with an energy release equivalent to that resulting from the detonation of 57,000 tons of TNT.

b. Another method of rating in common usage, and one which is often confused with the rating of *energy* in terms of TNT *energy* equivalence, is the rating of *effects* in terms of TNT *effects* equivalence, i. e., the *effect* of a particular phenomenon of a nuclear detonation expressed in terms of the amount of TNT which would produce the same *effect*. An example of TNT effect equivalence would be the expression of the crater radius of a nuclear surface burst in terms of the amount of TNT which would be required to produce the same radius.

c. For convenience these TNT equivalences are expressed in 1,000 ton or 1,000,000 ton units, KT (kiloton) or MT (megaton), where 1 ton equals 2,000 pounds and the energy content of TNT is defined as 1100 calories per gram.

d. A "nominal" weapon is one the yield of which is 20 KT. The use of this term arose from the approximately 20 KT yields at Hiroshima, Nagasaki, and the Bikini (Crossroads) tests. In some reports nuclear weapons effects data are based on the nominal weapon.

1.3 Data Presentation

This manual is divided into two parts. Part One, *Physical Phenomena*, treats the basic phenomena of blast and shock, thermal radiation, and nuclear radiation resulting from a nuclear explosion in various media and under various conditions. Part Two, *Damage Criteria*, discusses the mechanism of casualty production and damage to military targets, correlating the basic physical phenomena of a nuclear detonation with various defined degrees of damage.

Relatively simple scaling procedures exist for relating the majority of phenomena associated with weapons of one yield to weapons of other yields. For simplicity and convenience in the use of the manual, most physical phenomena data and much of the damage data are presented for 1 KT bursts, from which the phenomena or damage for other yields may be readily obtained by means of the appropriate scaling procedures which are explained wherever their use is required.

An estimate of the degree of reliability accompanies the presentation of nearly all physical

phenomena data. This estimated reliability indicates a range of values above and below the curve such that, for a large number of events, 90 percent of the data will fall within this range. Statements regarding reliability of damage data, on the other hand, describe the source and relative quantity of the data. Reliability estimates do not include operational considerations such as aiming error, target intelligence, and height of burst or yield variations.

1.4 Types of Burst

a. *General*. The medium in which a weapon is burst determines in great measure the relative magnitudes of the various physical phenomena. In particular, large differences result depending upon whether the detonation occurs in air above the surface, at the surface, or beneath the surface. It is often convenient to discuss weapon phenomena by these types of burst.

b. *Brief Description of an Air Burst*.

- (1) *Definition*. An air burst is defined as the explosion of a nuclear weapon at such a height that the weapon phenomenon of interest is not significantly modified by the earth's surface. For example, from a blast standpoint, this height is such that the reflected wave passing through the fireball does not overtake the incident wave above the fireball (heights greater than about $160 W^{1/3}$ feet $\pm 15\%$, where W is the weapon yield in kilotons). For thermal radiation an airburst occurs at such heights above the surface that the apparent thermal yield viewed from the ground is not affected by surface phenomena, such as heat transfer to the surface, distortion of the fireball by the reflected shock wave, thermal reflection from the surface, etc. (heights above the surface greater than about $180 W^{0.4}$ feet $\pm 20\%$ for yields of 10 KT to 100 KT, and $\pm 30\%$ for other yields). From the standpoint of fallout, an airburst occurs at such heights that militarily significant local fallout does not result (for yields less than 100 KT, a minimum height of burst of $100 W^{1/3}$ feet; for yields greater than 100 KT, in the absence of data,

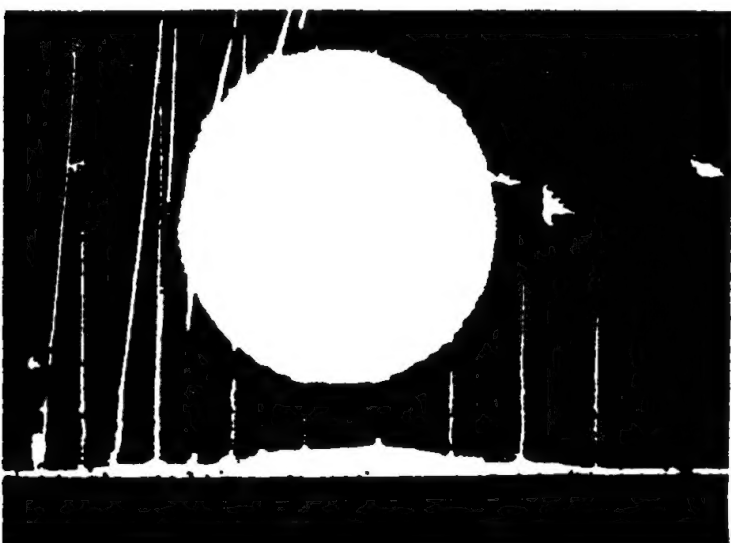
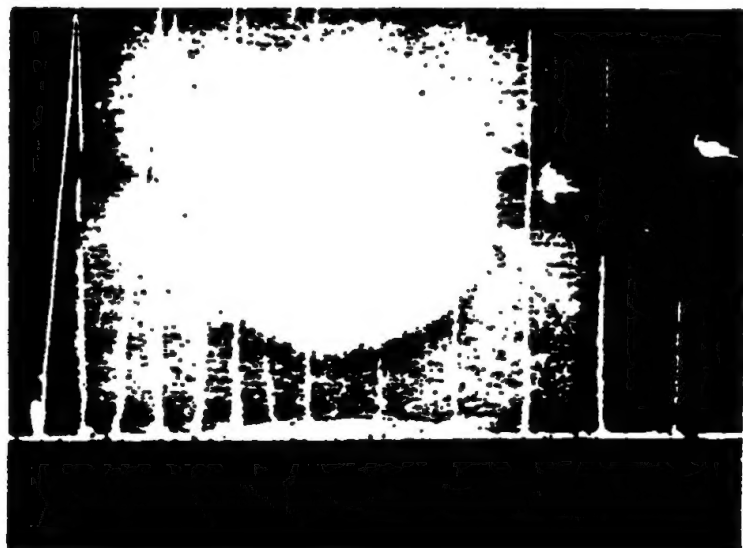
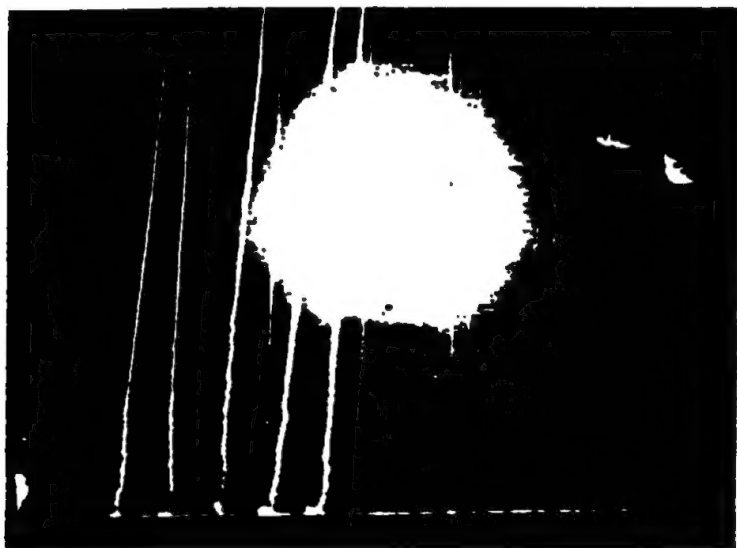

DEVELOPMENT OF AN AIR BURST

the minimum height of burst may be taken conservatively to equal $180 W^{0.4}$ feet). For certain other phenomena of interest, e. g., neutron induced activity, initial gamma or neutron flux, the height of burst at which the earth's surface fails to produce an effect is difficult or impossible to distinguish.

- (2) *Development.* Upon the detonation of a nuclear weapon, there occurs as a direct result of the fission and/or fusion process an emission of neutrons and of electromagnetic radiation in the form of a burst of gamma rays. The nuclear radiations are discussed further in (5) below and section IV.

The tremendous amount of energy created by the nuclear reaction gives rise

to extremely high temperatures, which in turn result in the vaporization of the fission products and the components of the weapon, and the emission of additional electromagnetic radiation covering a wide range of wave lengths from infra-red through visible to soft X-rays.

Until the temperature falls to about $300,000^{\circ}$ K. ($540,000^{\circ}$ F.), this additional electromagnetic radiation is the most rapid means of energy transfer, and hence is the means by which the surrounding air is heated to incandescence. When the temperature drops below about $300,000^{\circ}$ K., a shock wave becomes the primary mechanism for making the surrounding air incandescent. As long as the shock wave is strong enough to

cause the shock-heated air to be luminescent, the boundary of the observable luminous sphere (the fireball) is the shock front. Actually this observable sphere consists of two concentric regions. The inner (hotter) region is a sphere of uniform temperature, surrounded by a layer of shock-heated air at a somewhat lower but still very high temperature.

During the early stages of expansion of the incandescent shock front, the emitted radiant power increases as the luminous sphere increases in size, in spite of the fact that expansion causes a temperature decrease, until a maximum (the first maximum) is reached. At this point, the effect of the rapid rate of decrease in temperature overrides the enhancement of radiant power resulting from the increasing area of the luminous sphere.

Subsequently, further expansion causes a reduction in the radiant power. Eventually the shock front temperature is reduced to a point where the shock front is no longer incandescent; therefore, the rate of emission of radiation from the shock front is negligible. In effect, the shock front has become transparent, and the hotter incandescent inner core would be expected to be observable. Initially, however, the radiation emitted from the inner core is absorbed by compounds formed in the shock heated air, and the radiant power reaches a minimum. As these compounds break down, the radiant power emitted from the inner core begins to pass through, and the inner core becomes the visible source of radiation. Thus, the radiant power increases again. This change in boundary of the observable luminous sphere from the shock front to the incandescent inner core gives rise to the term "break-away."

As the opacity of the shock-heated air decreases, the apparent temperature as measured from a distance approaches that of the hot gases of the inner core, and the emitted radiant power ap-

proaches a second maximum. Further expansion and radiative cooling of the hot gases, however, give rise to a slow decrease in the radiant power. This decrease is so slow, relative to the previous rises and decline, that a large percentage of the total radiant energy emitted is delivered during this period. Finally, the rate of delivery of radiant energy drops to a low value.

The subsequent characteristics of the shock, or blast, wave are discussed in (3) below and section II. The effects of the thermal pulse are discussed in section III.

- (3) *Blast wave.* A blast wave is characterized by a sharp rise in pressure, temperature and density at its shock front. Thus, upon the arrival of a blast wave at a given location from the burst point, the sequence of events is a sudden increase in pressure, temperature and density, followed by a subsequent decrease in pressure, temperature and density to values below ambient, and a more gradual return to ambient conditions with the temperature going slightly above ambient. The overall characteristics of the blast wave are preserved over long distances from the burst point, but vary in magnitude with distance. With increase in distance, for example, the maximum pressure in the shock wave decreases, and the length of time over which the blast pressure is above ambient, the "positive phase," increases. In addition, under conditions of high relative humidity (50 percent or higher), the drop in air pressure below ambient lowers the temperature sufficiently to cause condensation of atmospheric moisture to form a large cloud called the Wilson Cloud. When the air pressure again becomes normal, in a matter of seconds, the cloud disappears. Although quite spectacular, the Wilson Cloud always occurs too far behind the shock front to modify the blast effects and too late to reduce the thermal effects appreci-

ably; therefore, the cloud has no military significance.

Also characteristic of a blast wave is the motion of the air away from the burst point during the positive phase and toward the burst point during the negative phase. The pattern of the air motion or air velocity is the same as for the other characteristics, with maximum velocity occurring just behind the shock front and decreasing with distance from the burst point. At 300 yards from the burst point of a 1 KT weapon, the peak wind velocity is about 240 miles per hour.

- (4) *Thermal radiation.* The relatively large amount of thermal radiation emitted in a nuclear detonation is one of its most striking characteristics. This radiant energy amounts to approximately one-third of the total energy of an air burst weapon. For a 1 KT weapon most of this radiation is emitted in less than a second, and is sufficient to cause serious burns to exposed personnel and to start fires in some combustible materials out to distances of about a thousand yards.
- (5) *Nuclear radiation.* A unique feature of a nuclear explosion is the nuclear radiation released. This consists of gamma rays, neutrons, alpha particles and beta particles. About a third of this energy is emitted within the first second after detonation, the remainder being released from radioactive fission products and unfissioned bomb materials over long periods of time after the burst. Nuclear radiation is primarily an anti-personnel effect, with the penetrating radiations (gamma rays and neutrons) being the most dangerous. Lethal doses of initial gamma radiation from a 1 KT burst are received by exposed personnel out to about 700 yards. Residual nuclear radiation, due either to fallout or to neutron-induced gamma activity, can under certain conditions deny entry into a bombed area for some period of time after a detonation. Nuclear radiation effects on materials and equipment are

negligible, except for sensitive photographic materials and certain electronic components.

- (6) *Cloud.* Because of its relatively low density compared to ambient conditions, the mass of hot gases comprising the fireball rises. The rate of rise may reach several hundred feet per second, after which it decreases rapidly. As the gases rise, they expand, cool and condense, forming a radioactive cloud which consists largely of water vapor and metallic oxides from the weapon. As the fireball cools, the color changes gradually from red to a reddish brown, and ultimately water vapor from the air condenses sufficiently to produce a white color. As the heated mass of air in the fireball rises, cool air is pulled in from the sides and below, which may cause a doughnut shaped ring to form around the column of hot air. This part of the cloud rolls violently as it rises. The cloud from a 1 KT detonation may reach a height of 5,000 to 10,000 feet above the burst point, after which it is gradually dispersed by the winds.

c. *Brief Description of a Surface Burst.*

- (1) *Definition.* A surface burst is defined as the explosion of a nuclear weapon at the earth's surface.
- (2) *Development and air blast wave.* When a nuclear weapon is burst at the surface of the earth the sequence of events in the development of the fireball and the formation of the blast wave is the same as that for an air burst, except that the fireball boundary and the shock front are roughly hemispherical. Since the earth's surface is an almost perfect reflector for the blast wave, the resulting blast effects are about the same as for a burst of twice the yield in free air.
- (3) *Ground shock.* When a burst takes place on the ground surface, a portion of the energy is directly transmitted to the earth in the form of ground shock. In addition, the air blast wave induces a ground shock wave which at shallow depths has essentially the same mag-

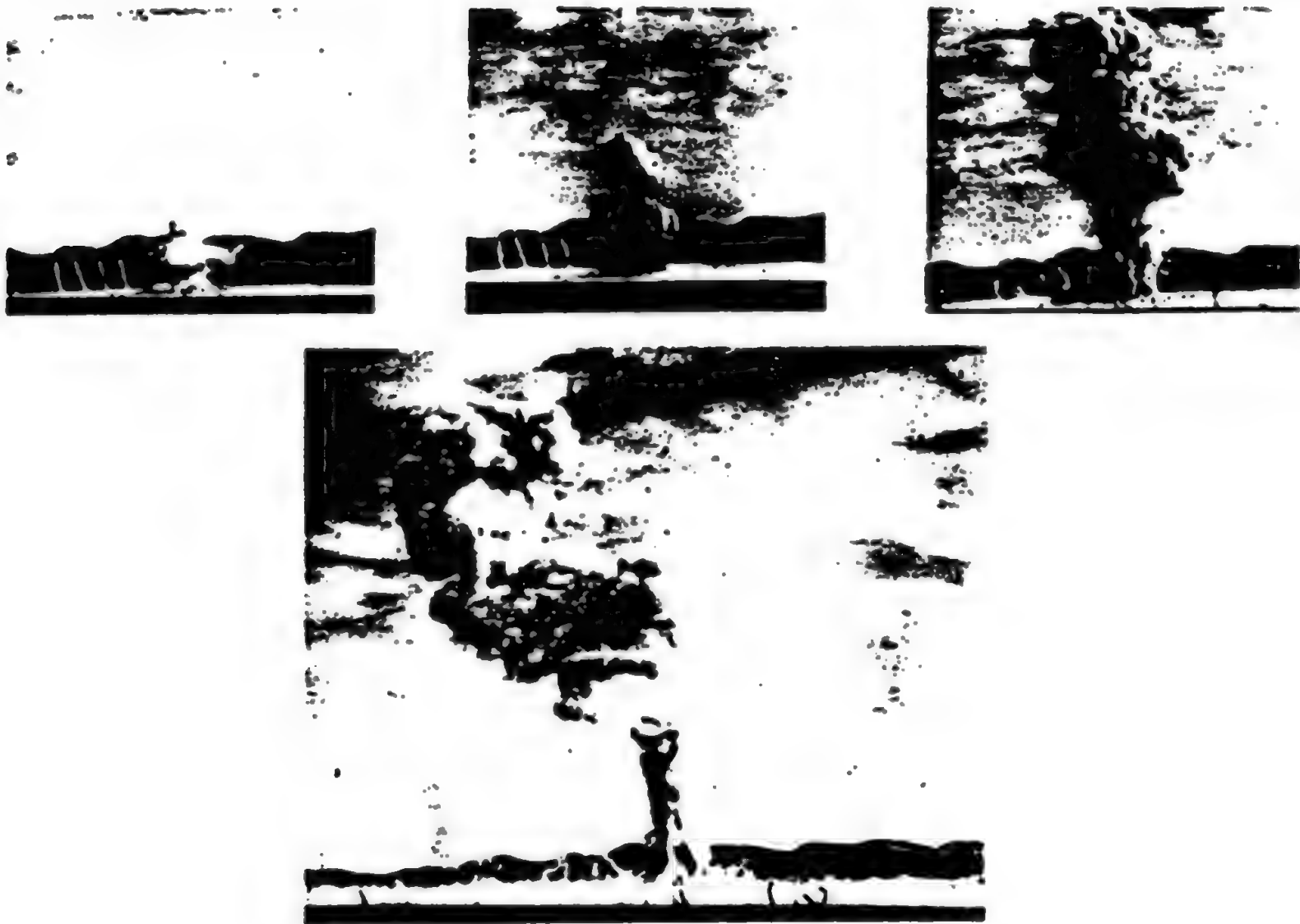

DEVELOPMENT OF A SURFACE BURST

nitude as the air blast wave at the same distance from the burst. The directly transmitted ground shock, although of higher magnitude initially, attenuates faster than the air blast induced shock.

- (4) *Crater.* For a burst on land, pressures of hundreds of thousands of pounds per square inch are exerted on the earth's surface, displacing material to form a crater and causing a downward compression of the soil. In addition to the material thrown out and compressed, a considerable quantity of earth is vaporized by the intense heat. A crater approximately 125 feet in diameter and 28 feet in depth is formed by a 1 KT weapon burst on a dry soil surface.
- (5) *Thermal radiation.* Because of the heat transfer to the surface, the hemispherical

shape of the fireball and the partial obscuration of the fireball by earth or water, the radiant exposure received by surface targets from a nuclear weapon burst on the surface is somewhat less than would be delivered by an air burst nuclear weapon of the same yield.

- (6) *Nuclear radiation.*

- (a) *Initial.* For a small yield weapon, owing largely to absorption by the surface, the initial gamma radiation from a surface burst is somewhat less at the same distance from the burst point than that from a burst of the same yield in free air. For high yield weapons, where hydrodynamic effects become important, a surface burst can be expected to produce as much or more initial gamma radiation as a

burst of the same yield in free air, at the same distance from the burst point.

(b) *Residual.* The contamination effects of residual nuclear radiation from a surface burst are very much greater than for an air burst, and hazardous radiological effects are produced over areas much greater than those seriously affected by blast or by thermal radiation. Roughly half of the available radioactivity resulting from a nuclear explosion on land, for example, can be expected to fall out in the general vicinity of the burst point. Dose rate contours near the burst point as great as 10,000 r/hr at $H+1$ hour have been observed at tests, regardless of yield.

(7) *Cloud.* For a burst on the surface, a great quantity of material is thrown out from the point of detonation. As the fireball rises, some material is drawn up under the fireball, forming a stem and sometimes forming a second cloud below the one which develops from the fireball. The stem and cloud(s) continue to rise and follow the course described for an air burst.

(8) *Surface bursts on water.* In general, the phenomena as outlined in (2), (5), (6), and (7) above will occur for a surface burst on water. In addition, the expanding sphere of hot gases depresses the water, causing the formation of a surface wave train and the transmission of a directly coupled shock wave into the water. The expanding air blast wave induces a shock wave in the water, which at shallow depths has essentially the same magnitude as the air blast wave at the same distance from the burst. Although the directly coupled water shock is of higher magnitude initially, it attenuates faster than the air blast induced water shock. As the height of burst increases from zero, depression, surface waves, and directly coupled water shock become smaller in magnitude. The formation of a crater on the bottom as the result of a surface burst in shallow water

will depend on the depth of the water, yield of the weapon and other factors. A 1 KT weapon, for example, detonated on the surface of water 50 feet deep with a soft rock bottom, will form a crater 130 feet in diameter and 4 feet deep.

d. Brief Description of a Burst in the Transition Zone Between an Air Burst and a Surface Burst.

(1) *General.* There is a sizable zone above the earth's surface such that, for weapons detonated in the zone, the presence of the earth's surface significantly modifies one or more of the basic weapon phenomena. As the height of burst is successively lowered in this transition zone, the earth's surface plays an increasingly important role in modifying weapon phenomena; there is a gradual transition from the characteristics of an air burst to those of a surface burst. The upper boundary of the transition zone varies depending upon the phenomenon being considered, since the effect of the earth's surface ceases to be of importance at different scaled heights of burst for different phenomena, as mentioned in *b(1)* above and covered in more detail in the discussion of specific weapon phenomena.

(2) *Development.* The development of a burst in the transition zone generally follows the sequence of events described in *b(2)* above for an air burst.

(3) *Blast wave, thermal and nuclear radiation.* From the standpoint of blast, as the height of burst decreases from that of an air burst, peak air overpressures are more and more affected by the blast wave reflected from the surface, until total coalescence of the incident wave and the reflected wave occurs for a surface burst. From the standpoint of thermal radiation, the apparent thermal yield viewed from the ground decreases with increasing distortion of the fireball by the reflected blast wave, until the thermal yield and the fireball shape approach those characteristic of a surface burst. For nuclear radiation, local fall-out becomes increasingly more significant with decreasing height of burst.

and, especially for large yield weapons burst close to the surface, the hydrodynamic enhancement of the initial gamma radiation (see par. 4.2a(1)) becomes of considerable importance.

- (4) *Ground shock and crater formation.* As the height of burst is lowered, ground shock increases in magnitude. Crater formation commences at a height of burst in the region of $60W^{1/3}$ feet by the mechanism of compression and scouring of the soil. At a height of burst less than about $10W^{1/3}$ feet, the expanding gases from a nuclear detonation form a crater by vaporization, throwing and compressing the soil in an outward direction from the detonation. Below this height of burst, crater radius and depth approach those of a surface burst.

e. Brief Description of an Underground Burst.

- (1) *Definition.* An underground burst is defined as the explosion of a nuclear weapon in which the center of the detonation lies at any point beneath the surface of the ground.
- (2) *Development.* When an atomic weapon is detonated at a sufficient depth underground, the ball of fire formed is composed primarily of vaporized materials from the bomb and vaporized earth. At shallow depths light from the fireball generally may be seen from the time it breaks through the surface until it is obscured by dust and vapor clouds, a matter of a few milliseconds. The characteristics of the explosion and their related effects depend upon the depth, yield, and soil type. As the depth below the surface is increased, the characteristics depart gradually from those of a surface burst and finally, at depths of the order of 20 feet for a 1 KT detonation, the explosion exhibits the phenomena commonly associated with underground explosions. It is emphasized that the transition from the observed characteristics of a surface burst to those

of an underground burst is not sudden, but that the characteristics change gradually.

- (3) *Air blast.* Bursts at depths shallow enough to permit significant venting will produce air blast waves similar to those of air or surface bursts. As the depth of burst increases, the magnitude of the air blast will decrease.
- (4) *Column, cloud and base surge.* The first physical manifestation of an underground explosion at shallow depths is an incandescence at the ground surface directly above the point of detonation. This is almost immediately followed by large quantities of material being thrown vertically as a consequence of the direct ground shock reflection along the ground surface. Concurrently large quantities of gas are released. These gases entrain additional quantities of material and carry them high into the air in the form of a cylindrical column. As the column rises it fans out and forms a dense cloud. Some of the particles thrown vertically, together with the entrained particles, behave like an aerosol with a density considerably greater than the surrounding air. This aerosol subsequently falls downward in the immediate vicinity of ground zero, and the finer soil particles spread out radially along the ground to form a low dust cloud called the base surge. For a 1 KT weapon burst at a depth of 20 feet, it is estimated that the column will reach a height of approximately 420 feet and a diameter of 660 feet, and the cloud will be 4,400 feet in diameter and 5,000 feet in height. Dimensions of the base surge are discussed in paragraph 2.2. For shallower depths of burst, the column tends to assume the shape of an inverted cone rather than a cylindrical column and has a more pronounced radial throw-out. Shallower depths of burst also become less favorable for the formation

SECTION II BLAST AND SHOCK PHENOMENA

2.1 Air Blast Phenomena

a. *General.* The shock wave which propagates through air as a consequence of a nuclear explosion is commonly referred to as a blast wave. The head of the blast wave, called the shock front, causes an abrupt rise in both overpressure and dynamic pressure as it passes a given point, as illustrated at point B in figure 2-1. In the case of overpressure, this abrupt rise is followed by a decline to a pressure below ambient and then a

gradual return to ambient. The portion of the wave in which the overpressure is above ambient is termed the positive overpressure phase, while the remaining portion, where the pressure is below ambient, is called the negative pressure phase. The decrease in pressure below ambient in the negative phase is usually small in comparison with the increase in pressure in the positive phase.

The dynamic pressure associated with mass motion of air has a positive duration somewhat

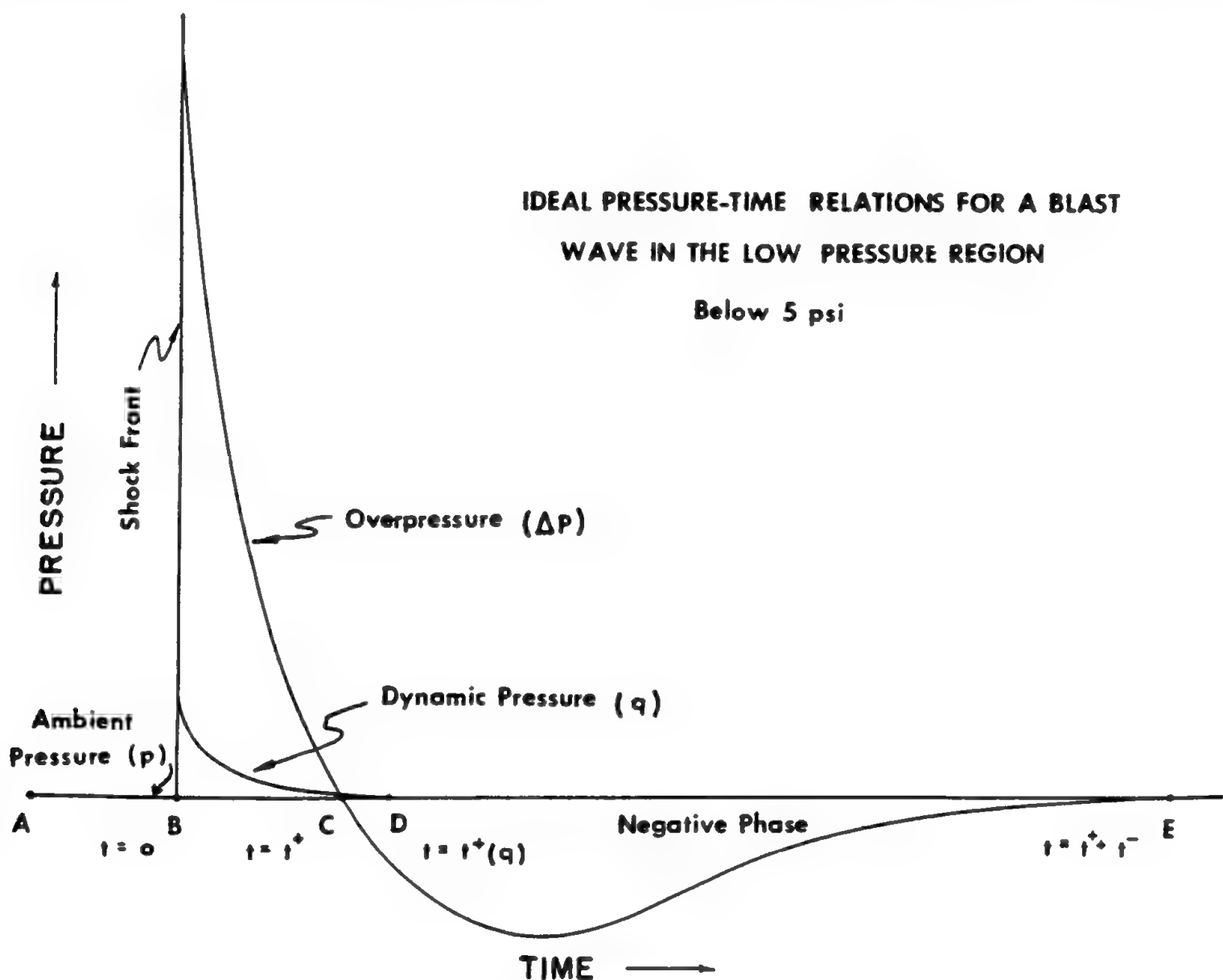

GROWTH OF THE MACH STEM
 (IDEALIZED)

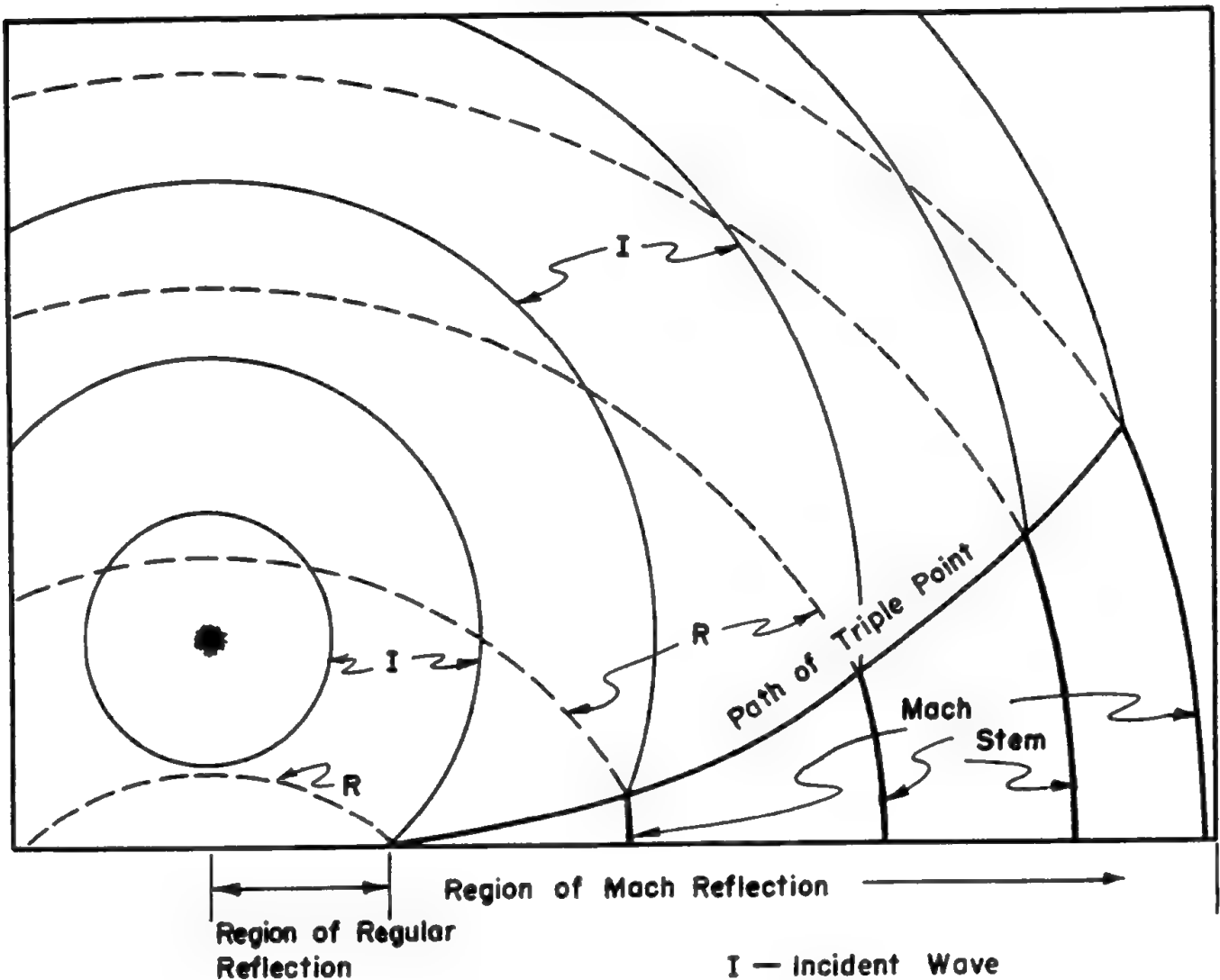

I — Incident Wave
 R — Reflected Wave

The characteristics of the blast wave at or near the surface, as well as the formation of the Mach stem, are dependent upon yield, height of burst, and the boundary or reflecting surface conditions. The region where the incident and reflected shocks have not merged to form a Mach stem is often referred to as the region of regular reflection; the region where they have merged is referred to as the region of Mach reflection. As the Mach stem travels along the surface, the triple point (the point of intersection of the incident wave, reflected wave, and the Mach stem) rises. The estimated height of the Mach stem as a function of height of burst and distance from ground zero is given in figure 2-7, for a 1 KT

burst. The procedure for scaling to other yields is illustrated in the example accompanying this figure. In addition to the fusing of the reflected and incident blast waves to form a Mach stem as just described, that portion of the reflected wave passing through the fireball of a burst in the transition zone will also fuse with that portion of the incident wave directly above the fireball. This fusion is primarily a result of the increased velocity of the reflected wave as it passes through the fireball, and as a consequence, is relatively narrow in lateral extent. As the height of burst varies from the surface to about $160 W^{1/3}$, the peak overpressures in the fused wave above the fireball vary from those ex-

pected from a particular weapon burst at the earth's surface to those expected from a free air burst of the same weapon. This is primarily the consequence of the spherical divergence of the reflected shock together with the dissipative effect of passing through a heated region.

(a) *Good surface conditions.* The preceding description of the reflection process considers the earth's surface as if it were an ideal reflector. For bursts over real target areas, however, the condition and nature of the surface must be considered, since it has been determined that under certain circumstances severe modifications of the blast wave may occur. These modifications are due to the physical characteristics of the surface, which result in thermal and mechanical effects on the blast wave. These effects will be discussed further in d(4) below. In a practical sense, the surfaces which most closely approach the ideal are ice, snow and water. These surfaces are considered as "good," since the influence of such surfaces in altering the blast wave is expected to be a minimum. The air blast characteristics for nuclear detonations over such "good" surfaces are presented in figures 2-8A, 2-9, and 2-11A.

(b) *Average surface conditions.* As noted above, the characteristics of the blast wave can be appreciably influenced by the type and condition of the surface over which it passes. In many target areas, it is expected that a significant thermal layer will form near the surface prior to shock arrival. The interaction of the incident blast wave with this thermal layer may affect the reflection process to a considerable degree, depending on the intensity of the thermal layer. Thus individual blast wave parameters such as shock velocity, peak overpressure, particle velocity, peak dynamic pressure and duration, as well as arrival times, wave forms and impulse values,

will be affected. The nature of these perturbations depends on the height of burst and ground range involved, and to a lesser extent on the yield. They are important for surface bursts, bursts in the transition zone, and air bursts over such surfaces as desert sand, coral, wooded and agricultural areas. In general, severe thermal effects on the blast wave may be expected over such surfaces for burst heights up to $650 W^{1/3}$ feet, while moderate to light thermal effects may be expected for burst heights between $650 W^{1/3}$ and $800 W^{1/3}$. However, these thermal effects are not expected in regions where pressures are below 6 psi for bursts over any surface. Mechanical influences on the blast wave may be present for any pressure level, but their relative importance is considerably less than the thermal effects previously mentioned. A detailed discussion of thermal and mechanical effects is given in d(4) below. The air blast characteristics for nuclear detonations over the real surfaces described above are presented in figures 2-8B, 2-10, and 2-11B. These figures should be used as representative for all target areas where surface conditions cannot be considered as good.

(2) *Time of arrival.* The time of arrival of the shock front on the surface is given in figure 2-8 as a function of height of burst and ground range for a 1 KT burst in a homogeneous sea level atmosphere. For other yields, cube root scaling applies to burst heights, ground range and time. Figure 2-8A applies to good surface conditions while 2-8B applies to average surface conditions.

(3) *Peak overpressure.*

(a) *General.* For given surface conditions, the variation of peak overpressure with distance as a function of the height of burst is presented in "height of burst" curves. Curves for good surface conditions are shown in figure

2-9, while those presented in figure 2-10 are considered appropriate for all other target areas. These figures give distances from ground zero at which various peak overpressures will be attained on the ground surface from a 1 KT explosion at different heights of burst in a homogeneous sea level atmosphere. In order to scale to other yields, the height of burst and the distance at which a given overpressure occurs are multiplied by the cube root of the selected yield. This procedure is illustrated in the example which accompanies these figures. Study of figure 2-10 reveals that if it is desired to obtain the maximum ground range for an overpressure of 10 psi or less, a height of burst should be selected which coincides as nearly as possible with the extreme right projection, sometimes called the "knee," of the desired pressure contour. If the range of an overpressure at the surface greater than 10 psi is of interest, it will be seen that the maximum coverage is obtained from bursts close to the ground (i. e., the extreme right projection of the curve occurs at low heights of burst).

(b) *Duration.* The duration of the positive phase of the blast wave at the surface depends upon height of burst, distance from ground zero, yield, and surface conditions. This dependence is illustrated in figure 2-11 for a 1 KT burst at sea level. Figure 2-11A applies to good surface conditions while 2-11B applies to average surface conditions. Accompanying figure 2-11 is the scaling procedure for other yields with an example of its use.

(c) *Impulse and wave forms.* The overpressure positive phase impulse is obtained from the area under the positive phase of the overpressure-time curve. The exact value at or near a reflecting surface for a particular range depends on the height

of burst and yield, as well as the extent of perturbation of the wave form as noted above. The classical wave form previously discussed for free air overpressures (characterized by an instantaneous rise to a peak value at shock arrival, followed by an exponential decay in some manner dependent upon shock strength) is seldom found along the surface for overpressure levels above 6 psi. Only for such specialized surface conditions as snow, ice and water, where thermal effects on the blast wave are expected to be at a minimum, do the wave forms for higher overpressure levels approach the ideal. Even then, minor mechanical effects may be present; for example, over water the rise time may not be instantaneous and there may be a slight rounding of the peak value of the overpressure wave form. In general, non-ideal overpressure wave forms which reflect precursor action will result for those bursts over such real surfaces as desert sand, coral, wooded and agricultural areas where significant thermal effects on the blast wave may be expected. The variation in the overpressure wave shape depends on height of burst and ground distance. For a detailed discussion of wave form types and overpressure impulse to be expected under various conditions, refer to appendix I. A detailed discussion of the precursor is given in d(4) below.

(4) *Dynamic pressure.*

(a) *General.* For given surface conditions, the variation of peak dynamic pressure at the surface with range depends on the yield and height of burst. This dependence is shown in the form of height of burst curves, such as those presented in figure 2-12 for 1 KT in a homogeneous sea level atmosphere for good surface conditions. These curves approach the ideal situation where thermal effects on the blast wave are

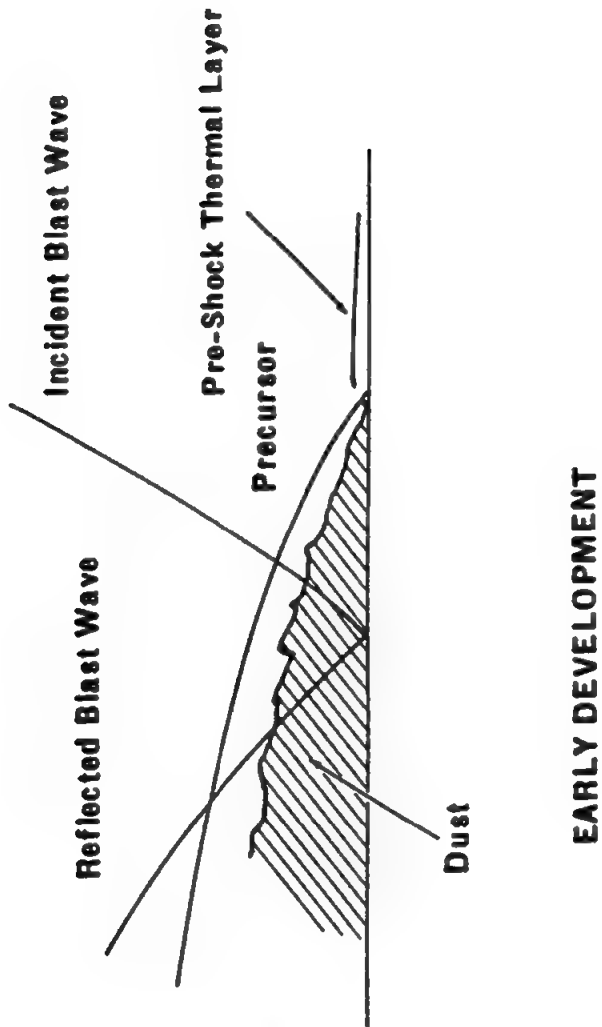
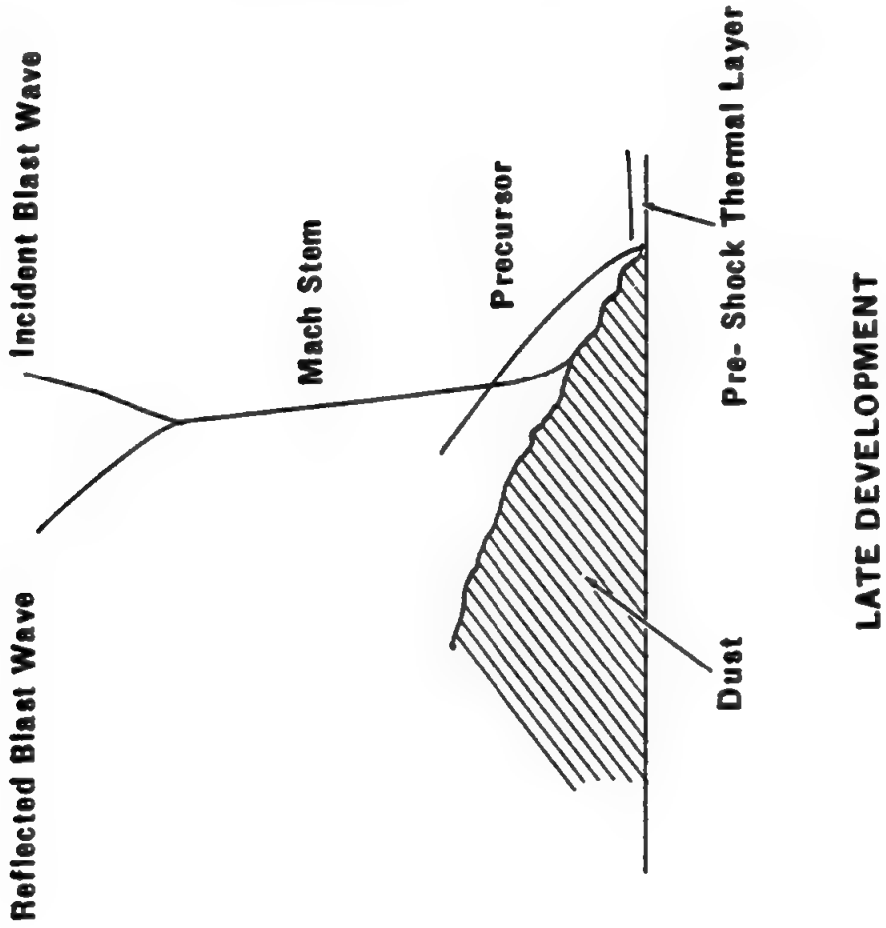

PRECURSOR CHARACTERISTICS

MACH STEM HEIGHT

Figure 2-7 is a plot of ground distance vs. Mach stem height for various heights of burst of a 1 KT detonation in a sea level atmosphere. These curves are for average surface conditions; depending upon the thermal qualities and the roughness of the surface, the triple point rise may be somewhat different from that shown.

Scaling. Distances scale as the cube root of the yield, so that—

$$\frac{H_1}{H_2} = \frac{h_1}{h_2} = \frac{d_1}{d_2} = \frac{W_1^{1/3}}{W_2^{1/3}}$$

where H_1 , h_1 and d_1 are Mach stem height, height of burst and ground distance for yield W_1 , and H_2 , h_2 and d_2 are the corresponding Mach stem height, height of burst and ground distance for yield W_2 .

Example.

Given: A 60 KT detonation at 1,000 feet height of burst.

Find:

- (a) The range at which the Mach stem is 50 feet high.
- (b) The minimum ground range for which an aircraft at 5,000 feet altitude is in the Mach reflection region.

Solution:

- (a) The corresponding burst height for 1 KT is—

$$h_1 = \frac{1,000 \times 1}{(60)^{1/3}} = 255 \text{ feet.}$$

The corresponding Mach stem height for a 1 KT burst is—

$$H_1 = \frac{50 \times 1}{(60)^{1/3}} = 13 \text{ feet.}$$

From figure 2-7, a Mach stem height of 13 feet is found at 95 yards for a 1 KT burst at 255 feet HOB. For a 60 KT burst, the range is $95 \times (60)^{1/3} = 370$ yards. *Answer.*

- (b) 5,000 feet altitude for a 60 KT burst

corresponds to $\frac{5,000}{(60)^{1/3}} = 1,280$ feet altitude for a 1 KT burst. Interpolating between the 200 feet and 300 feet burst height curves, the ground range for a Mach stem height of 1,280 feet is 810 yards. The corresponding range for a 60 KT burst is $810 \times (60)^{1/3} = 3,200$ yards. *Answer.* This indicates that for the burst condition and altitude specified, an aircraft at ranges greater than 3,200 yards will experience a single shock.

Reliability. The range at which a given Mach stem height occurs as obtained from figure 2-7 is considered to be reliable to ± 10 percent for 1 KT and to ± 25 percent for 20 MT. This decrease in reliability with increasing yield is a result of the lack of knowledge concerning the effect of atmospheric inhomogeneity on the triple point trajectory. It is suggested that no correction be made for altitude effects; however, when the basic data are applied to high yield air bursts, the results should be treated with somewhat less confidence.

Related material.

See paragraph 2.1.c(1).

See also figure 2-6.

MACH STEM HEIGHT (1 KT)

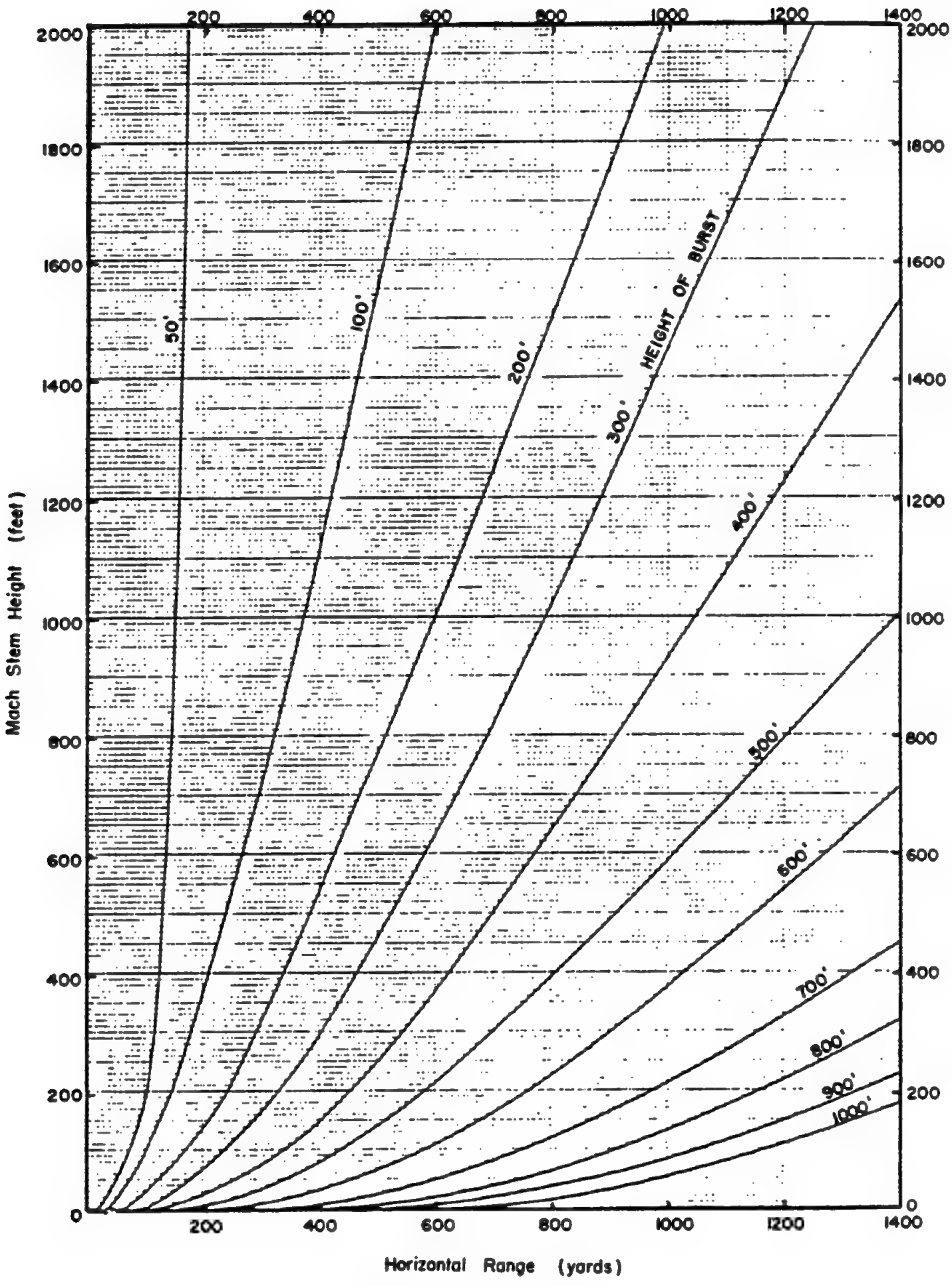

PEAK OVERPRESSURES ON THE SURFACE

(Good and Average Surface Conditions)

Figures 2-9 and 2-10 are families of curves representing peak overpressures on the ground as a function of ground range and height of burst for a 1 KT burst under sea level conditions. The solid lines are based upon experimental data established as a result of full-scale nuclear explosions and the dashed portions are based upon theory and high explosive experiments. The curves in figures 2-9A and 2-9B are considered representative for "good" target surfaces approaching the ideal, while the curves in figures 2-10A and 2-10B are considered appropriate for all other target conditions ("average"). Surface influences are discussed in paragraphs 2.1c and d(4).

Scaling. The height of burst and the range to which a given peak overpressure extends scale as the cube root of the yield, i. e.,

$$\frac{d_1}{d_2} = \frac{h_1}{h_2} = \frac{W_1^{1/3}}{W_2^{1/3}}$$

where for a given peak overpressure, d_1 and h_1 are ground range and height of burst for W_1 KT, and d_2 and h_2 are the corresponding ground range and height of burst for W_2 KT.

Example.

Given: An 80 KT detonation 2,580 feet above an average surface.

Find: The distance to which 3 psi extends.

Solution: The corresponding burst height for 1 KT is—

$$h_1 = \frac{W_1^{1/3} \times h_2}{W_2^{1/3}} = \frac{1 \times 2,580}{(80)^{1/3}} = 600 \text{ ft.}$$

From figure 2-10B, 3 psi extends to 920 yards for a 600 foot burst height for a 1 KT weapon. The corresponding distance for 80 KT is:

$$d_2 = \frac{W_2^{1/3} \times d_1}{W_1^{1/3}} = \frac{(80)^{1/3} \times 920}{1} =$$

3,960 yards. *Answer.*

Reliability. The pressures obtained from figures 2-9 and 2-10 are considered to be reliable to ± 20 percent for yields of 1 KT to 20 MT. Outside this range of yields the figures may be used with somewhat less confidence.

Related Material.

See paragraphs 2.1c(3) and d(4).

See also figures 2-3, 2-8, 2-11 through 2-13, and 2-18.

~~CONFIDENTIAL~~

PEAK OVERPRESSURE ON THE SURFACE AS A FUNCTION OF HEIGHT OF BURST AND HORIZONTAL RANGE
1 KT AT SEA LEVEL FOR GOOD SURFACE CONDITIONS

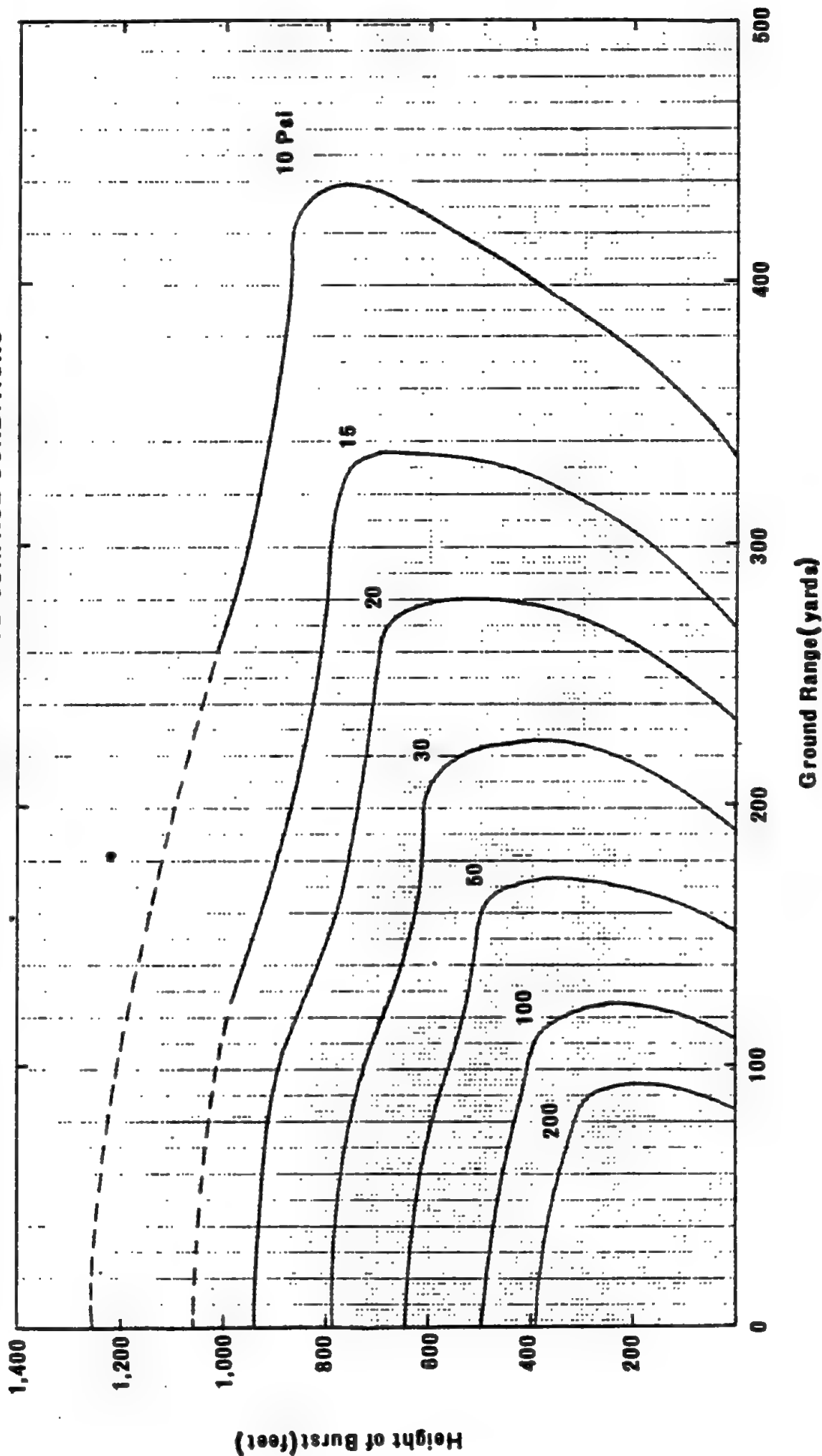

~~CONFIDENTIAL~~

PEAK OVERPRESSURE ON THE SURFACE AS A FUNCTION OF HEIGHT OF BURST AND GROUND RANGE
1 KT AT SEA LEVEL FOR GOOD SURFACE CONDITIONS

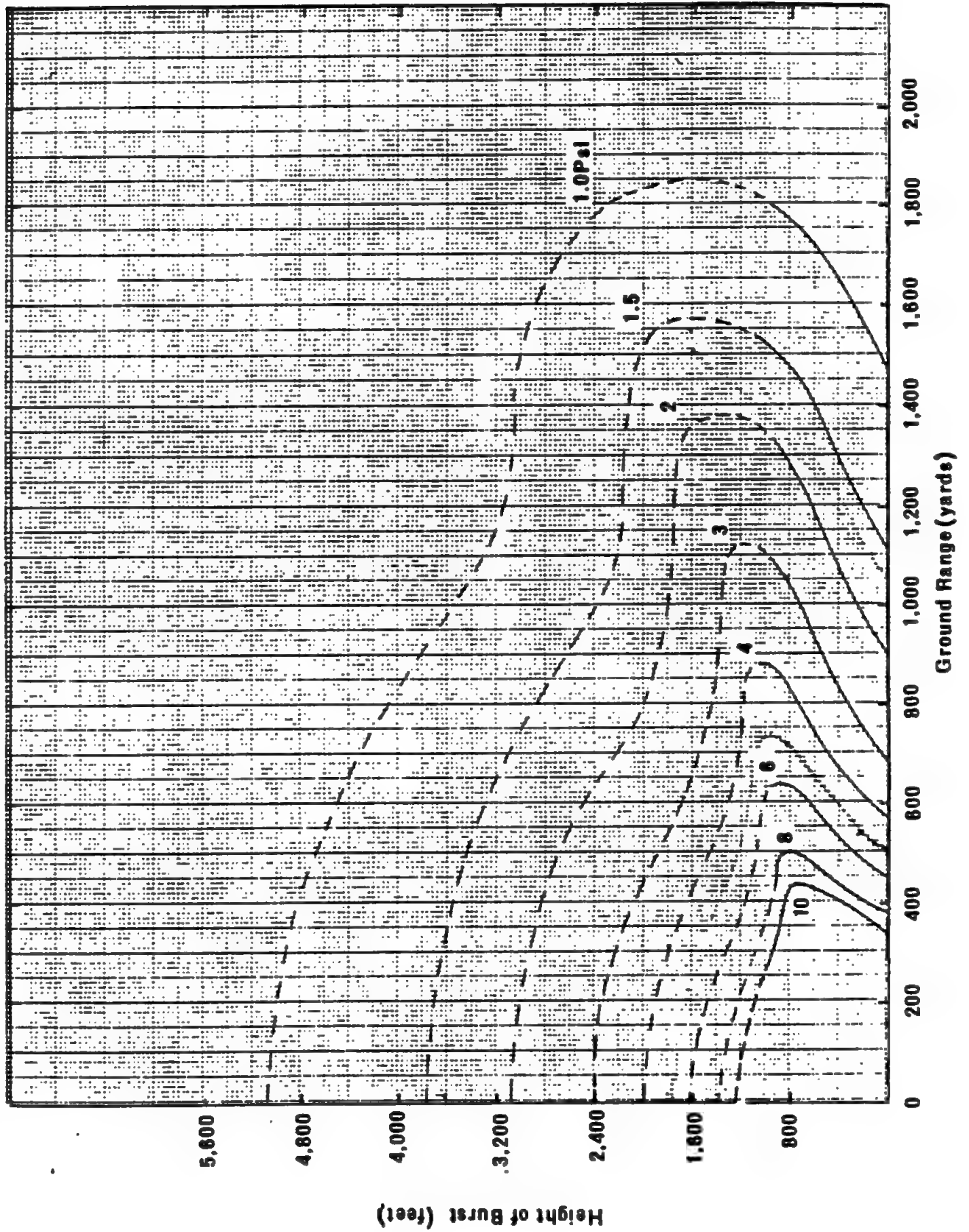

PEAK OVERPRESSURE ON THE SURFACE AS A FUNCTION OF HEIGHT OF BURST AND GROUND RANGE
1 KT AT SEA LEVEL FOR AVERAGE SURFACE CONDITIONS

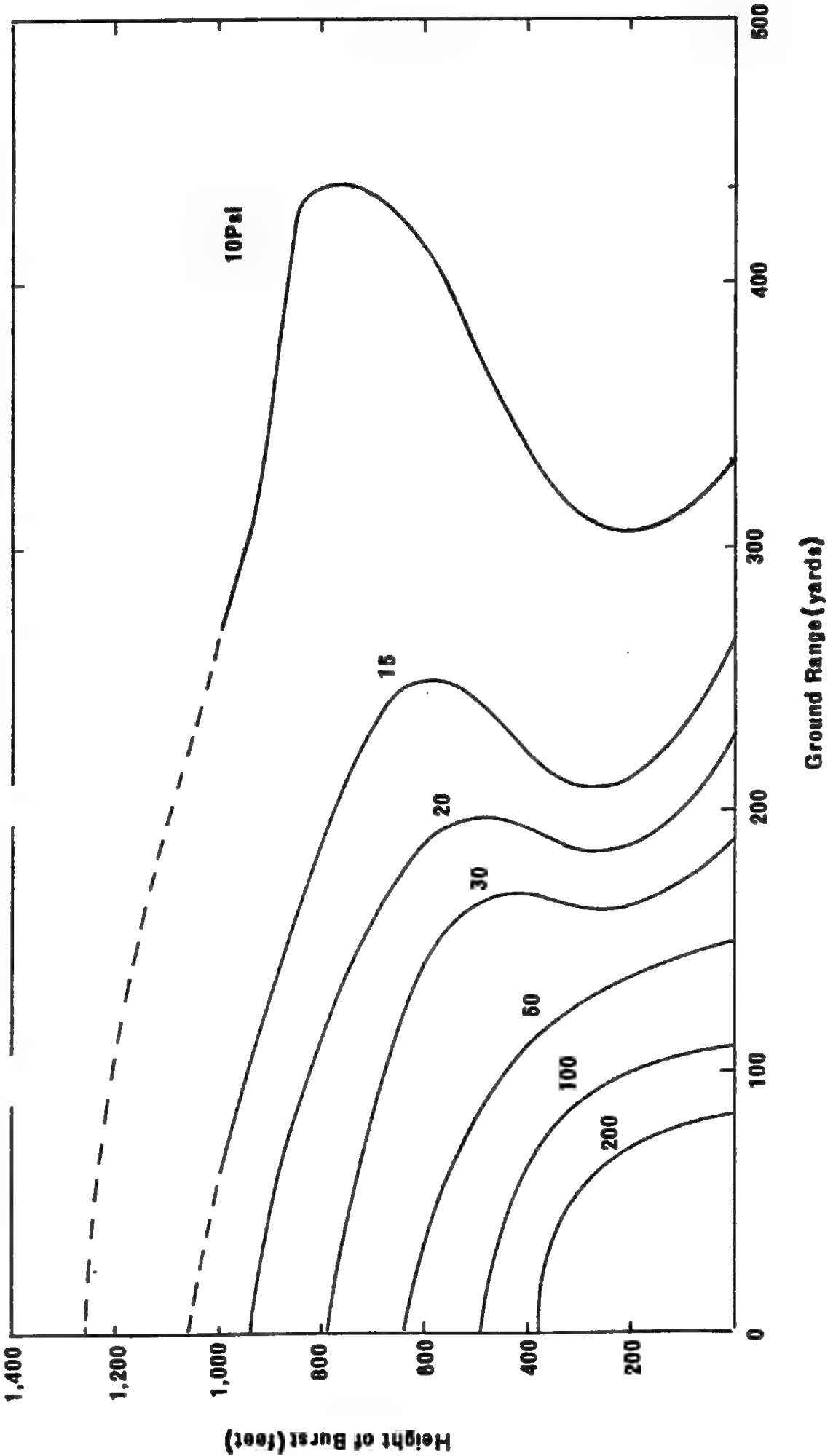

PEAK OVERPRESSURES ON THE SURFACE
AS A FUNCTION OF HEIGHT OF BURST AND HORIZONTAL RANGE
1 KT AT SEA LEVEL FOR AVERAGE SURFACE CONDITIONS

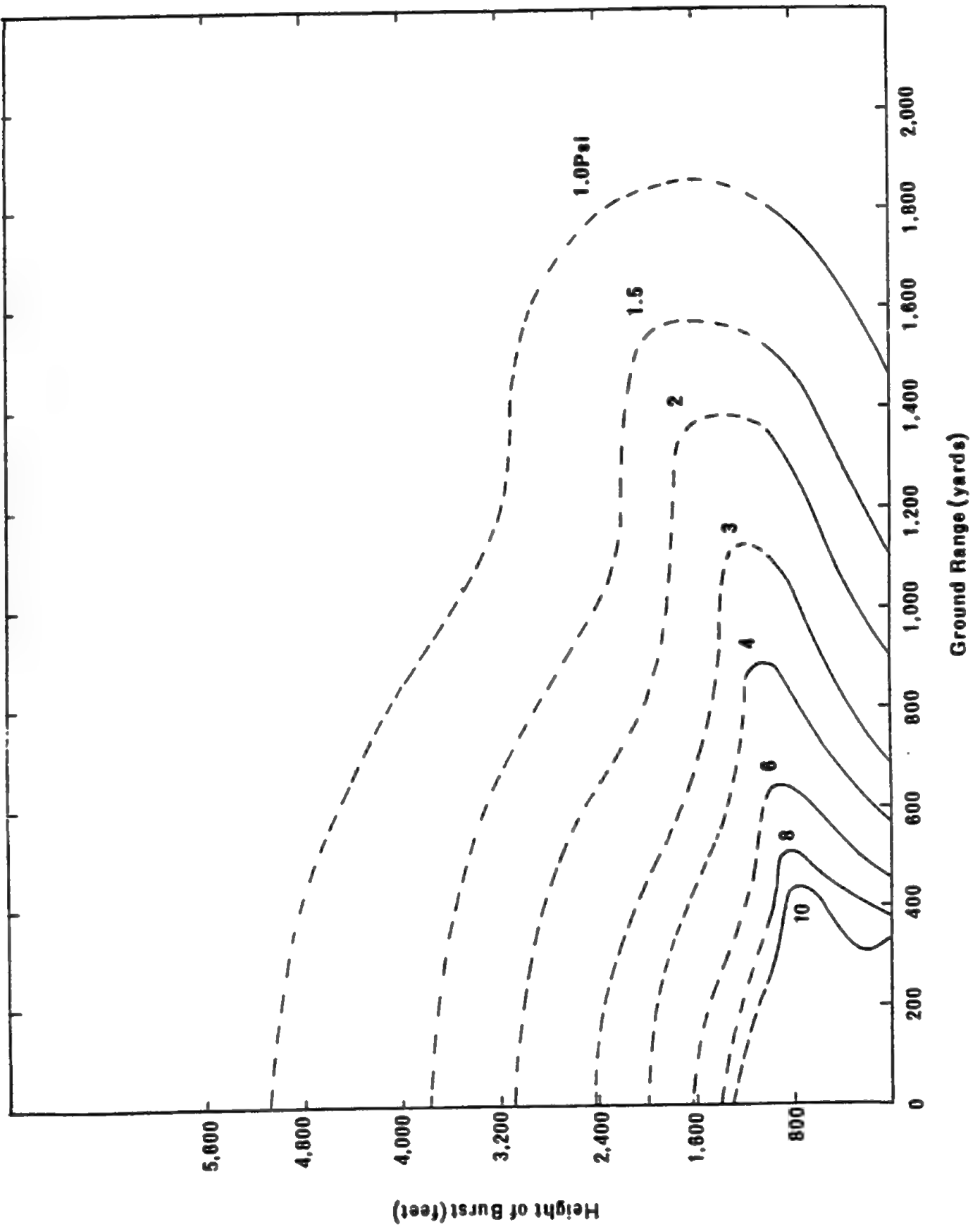

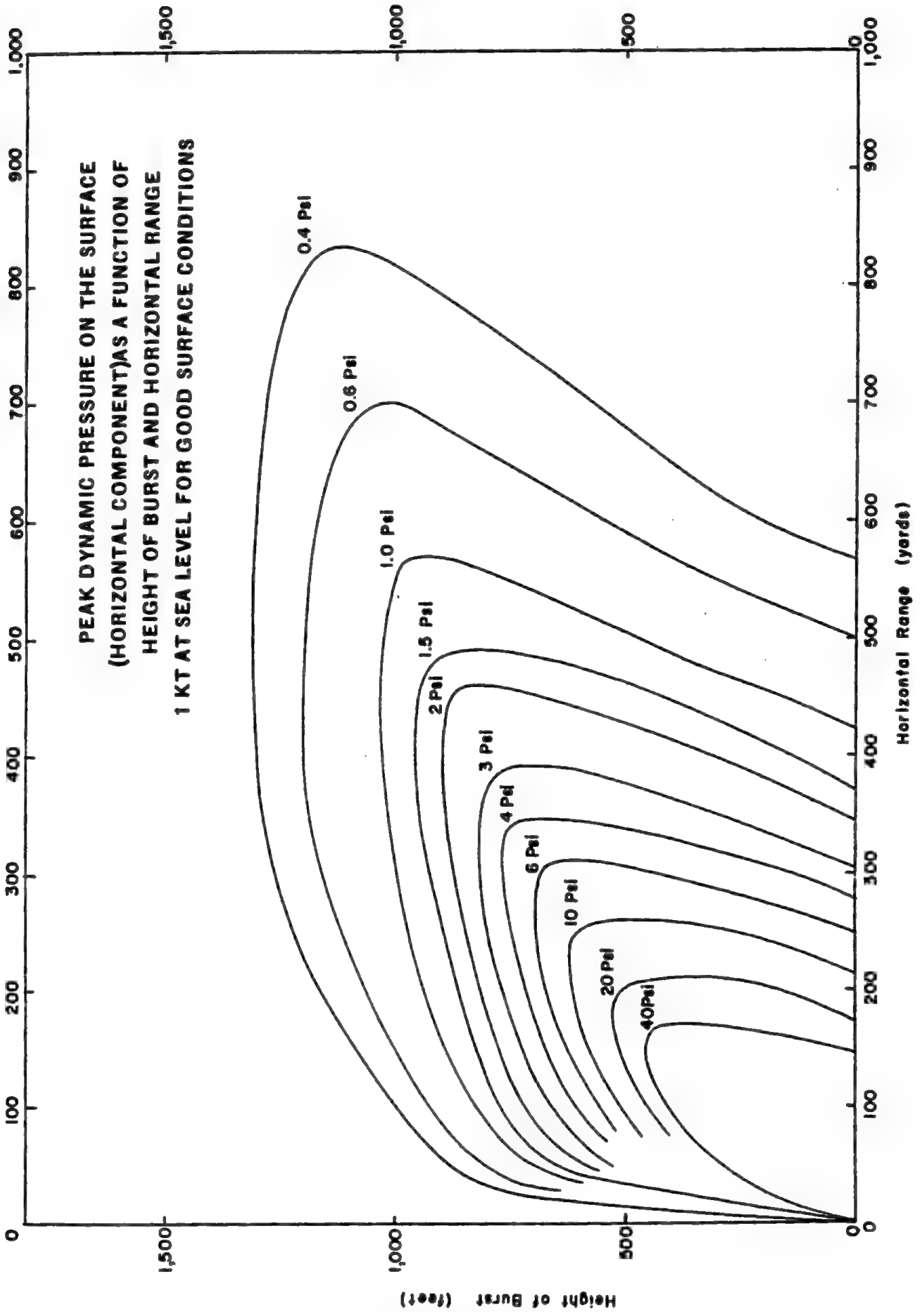

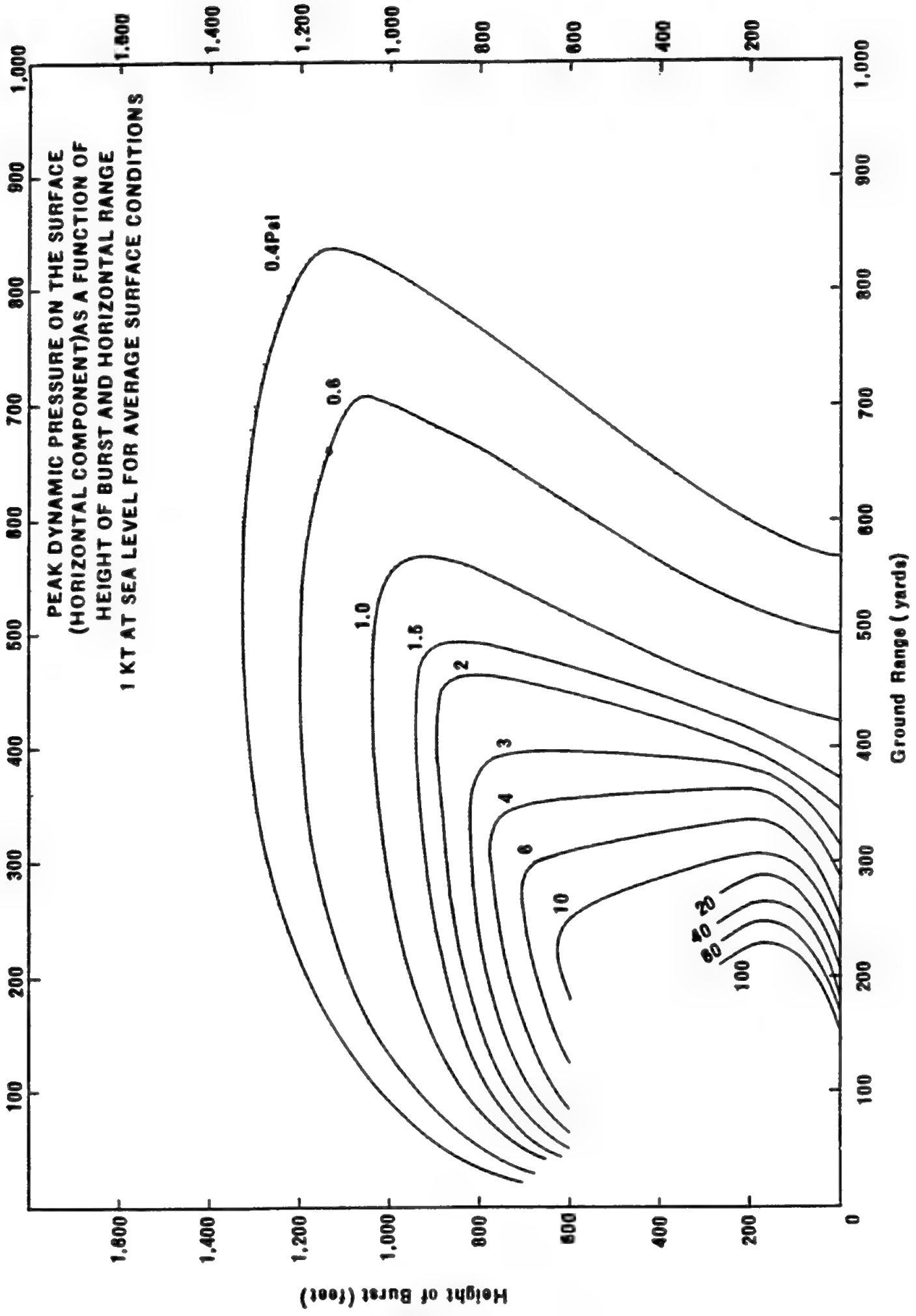

RAIN OR FOG EFFECTS ON PEAK OVERPRESSURE

Figures 2-14A and 2-14B present range correction factors as a function of height of burst and overpressure for a 1 KT detonation in rain or fog. The range to which a given overpressure would extend under normal conditions is multiplied by the correction factor to account for the presence of the rain or fog.

Scaling. Use the relation:

$$\frac{h_1}{h_2} = \frac{W_1^{1/3}}{W_2^{1/3}}$$

where h_1 = height of burst for yield W_1 , and h_2 = the corresponding height of burst for yield W_2 .

Example.

Given: A 30 KT burst at 600 feet in a moderate rain.

Find: The distances to which 8 and 30 psi extend on the ground surface under average surface conditions.

Solution: The corresponding burst height for 1 KT is:

$$h_1 = \frac{600 \times 1}{(30)^{1/3}} = 190 \text{ feet.}$$

From figure 2-10, the ground range for 8 psi overpressure is 380 yards and for 30 psi overpressure is 164 yards for a 1 KT burst. The corresponding ranges for a 30 KT burst are 1,200 yards (for 8 psi) and 530 yards (for 30 psi). From figure 2-14A (moderate rain), the correction factors for a burst at 190 feet are 0.9 (for 8 psi) and >0.99 (for 30 psi).

The range to which 8 psi extends in moderate rain is $1,200 \times (0.9) = 1,100$ yards. *Answer.*

The reduction in range for 30 psi is negligible; it therefore extends to 530 yards. *Answer.*

Reliability. At a given range obtained in this manner, overpressures are considered to be reliable within ± 40 percent.

Related material. See paragraph 2.1.d(2). See also figures 2-9, 2-10, and 2-18.

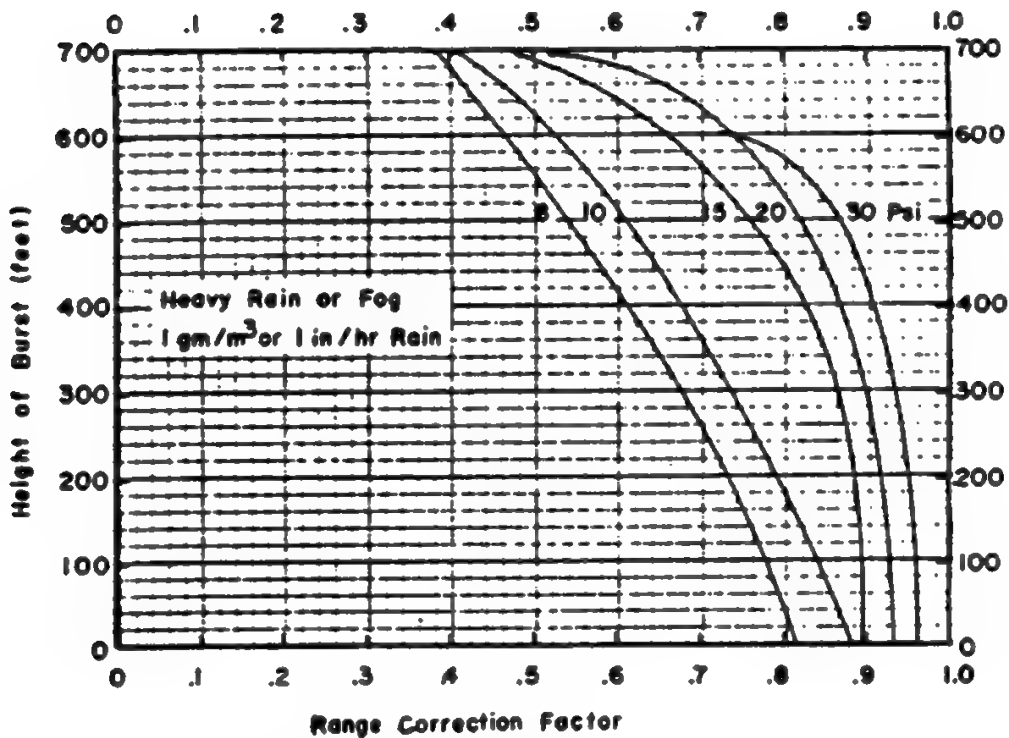
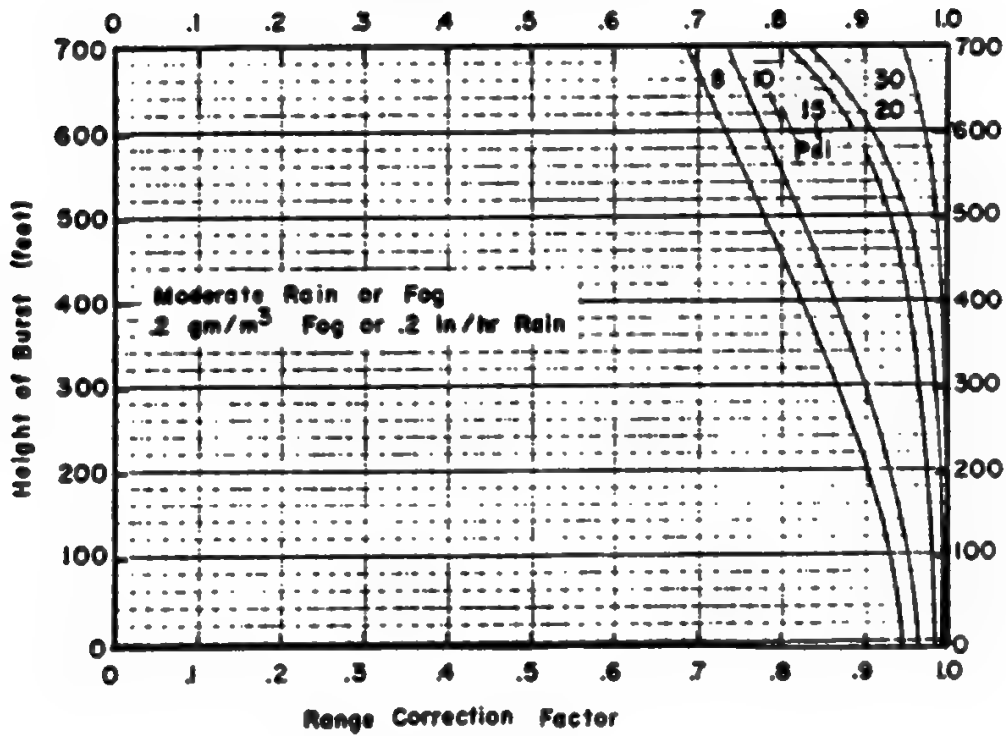

**RAIN OR FOG EFFECTS ON PEAK OVERPRESSURE
AS A FUNCTION OF HEIGHT OF BURST
FOR 1 KT AT SEA LEVEL**

CRITERIA FOR PRECURSOR FORMATION

Figure 2-17 gives conditions of burst height and yield for precursor formation over average surfaces, and may be utilized to predict precursor formation if these conditions are known.

Example.

Given: A 100 KT burst at 600 feet over an "average" surface.

Find: Whether or not a precursor may be expected.

Solution: Enter figure 2-17 with a height of burst of 600 feet and a yield of 100 kilotons. The intercept falls within the portion of the figure indicating a precursor will form. *Answer.*

Reliability. Based on data obtained from extensive full scale testing over desert surfaces and limited tests over coral.

Related material.

See paragraphs 2.1c and d(4), and appendix I. See also figure 2-16.

CRITERIA FOR PRECURSOR FORMATION(AVERAGE SURFACE CONDITIONS)

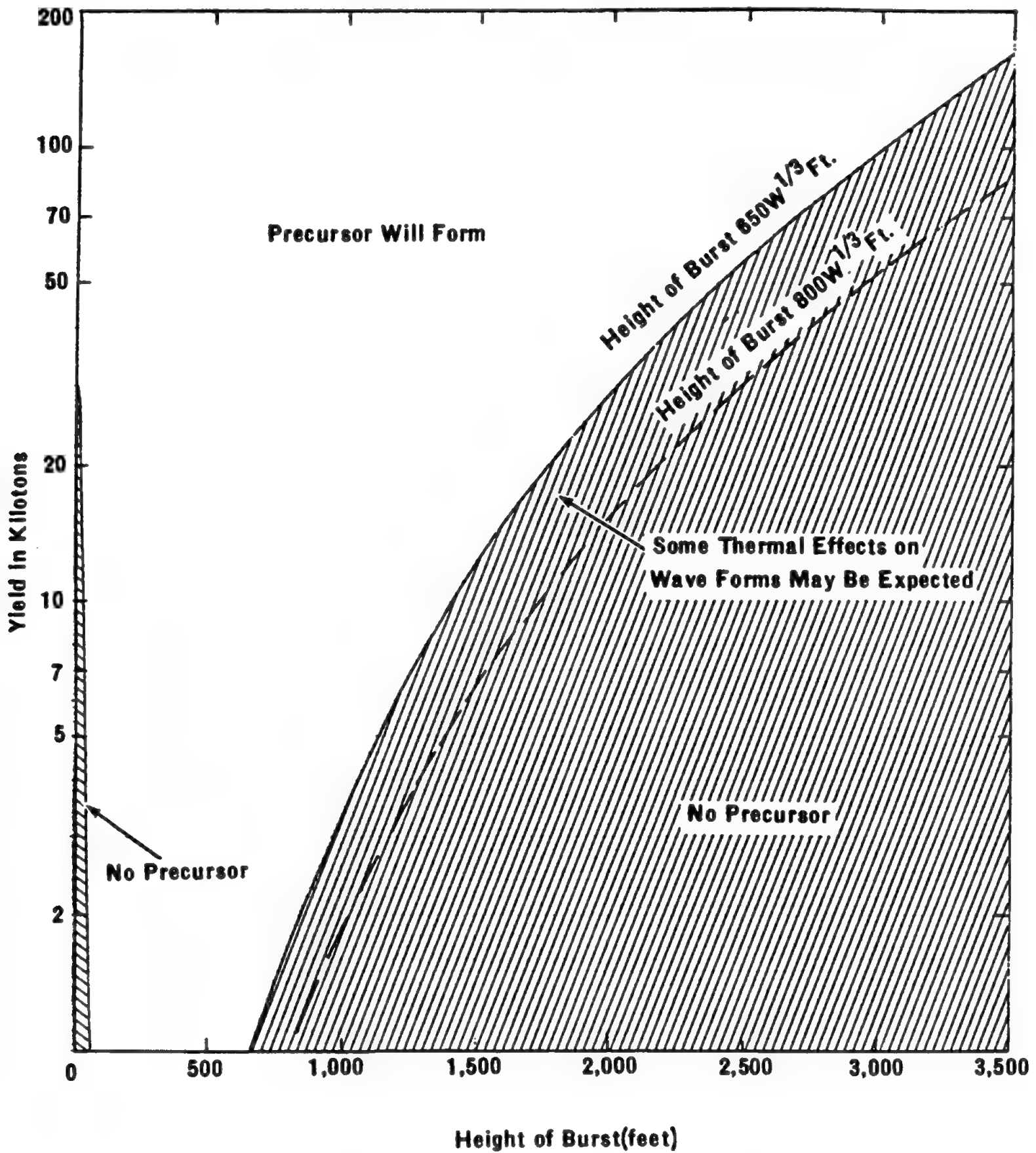

PEAK AIR OVERPRESSURES AT THE SURFACE AS A FUNCTION OF DEPTH OF BURST IN EARTH OR WATER AND HORIZONTAL RANGE

Figure 2-18 is a family of curves representing peak air overpressures on the surface as a function of depth of burst and surface range for a yield of 1 KT.

Scaling. The depth of burst and the range to which a given peak overpressure extends are directly proportional to the cube root of the yield:

$$\frac{d_1}{d_2} = \frac{h_1}{h_2} = \frac{W_1^{1/3}}{W_2^{1/3}}$$

where h_1 =depth of burst for yield W_1 KT, h_2 =the corresponding depth of burst for yield W_2 KT, d_1 =distance to which given overpressure extends for yield W_1 KT, d_2 =the corresponding distance to which given overpressure extends for yield W_2 KT.

Example.

Given: A 20 KT weapon burst 60 feet underground.

Find: The peak air overpressure 1,300 yards from surface zero.

Solution: Applying the above scaling to scale to 1 KT,

$$h_1 = \frac{W_1^{1/3} \times h_2}{W_2^{1/3}} = \frac{1 \times 60}{(20)^{1/3}} = 22 \text{ ft,}$$

$$\text{and } d_1 = \frac{W_1^{1/3} \times d_2}{W_2^{1/3}} = \frac{1 \times 1,300}{(20)^{1/3}} = 480 \text{ yd.}$$

The 22-foot depth line and 480-yard distance line intersect on figure 2-18 at about 4 (± 1) psi. *Answer.*

Reliability. The reliability of pressures taken from figure 2-18 is estimated to be ± 25 percent.

Related material.

See paragraph 2.1e.

See also figures 2-9 and 2-10.

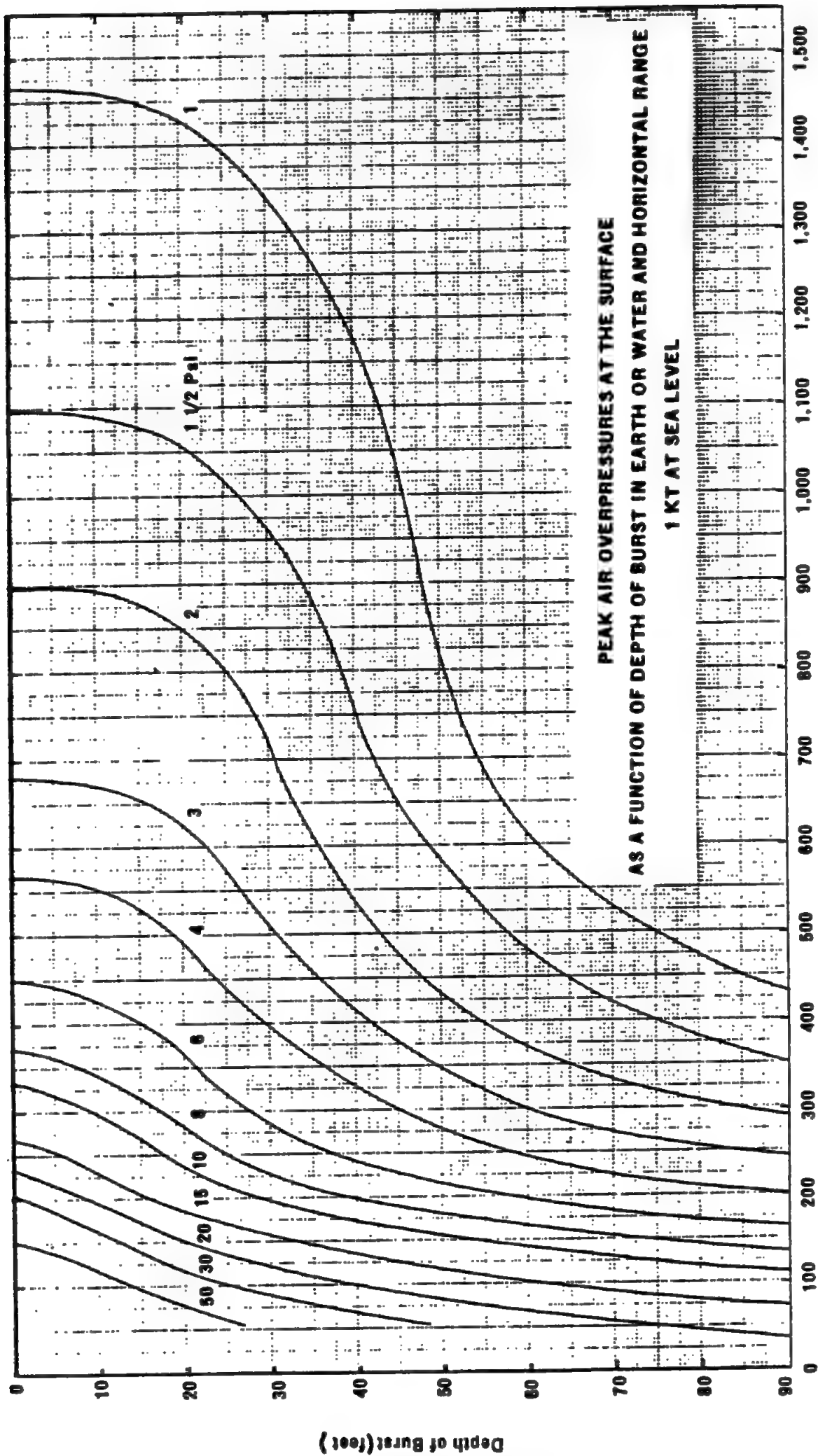

PEAK AIR OVERPRESSURES AT THE SURFACE
AS A FUNCTION OF DEPTH OF BURST IN EARTH OR WATER AND HORIZONTAL RANGE
1 KT AT SEA LEVEL

Horizontal Distance From Surface Zero (yards)

Depth of Burst (feet)

CRATER PROFILE

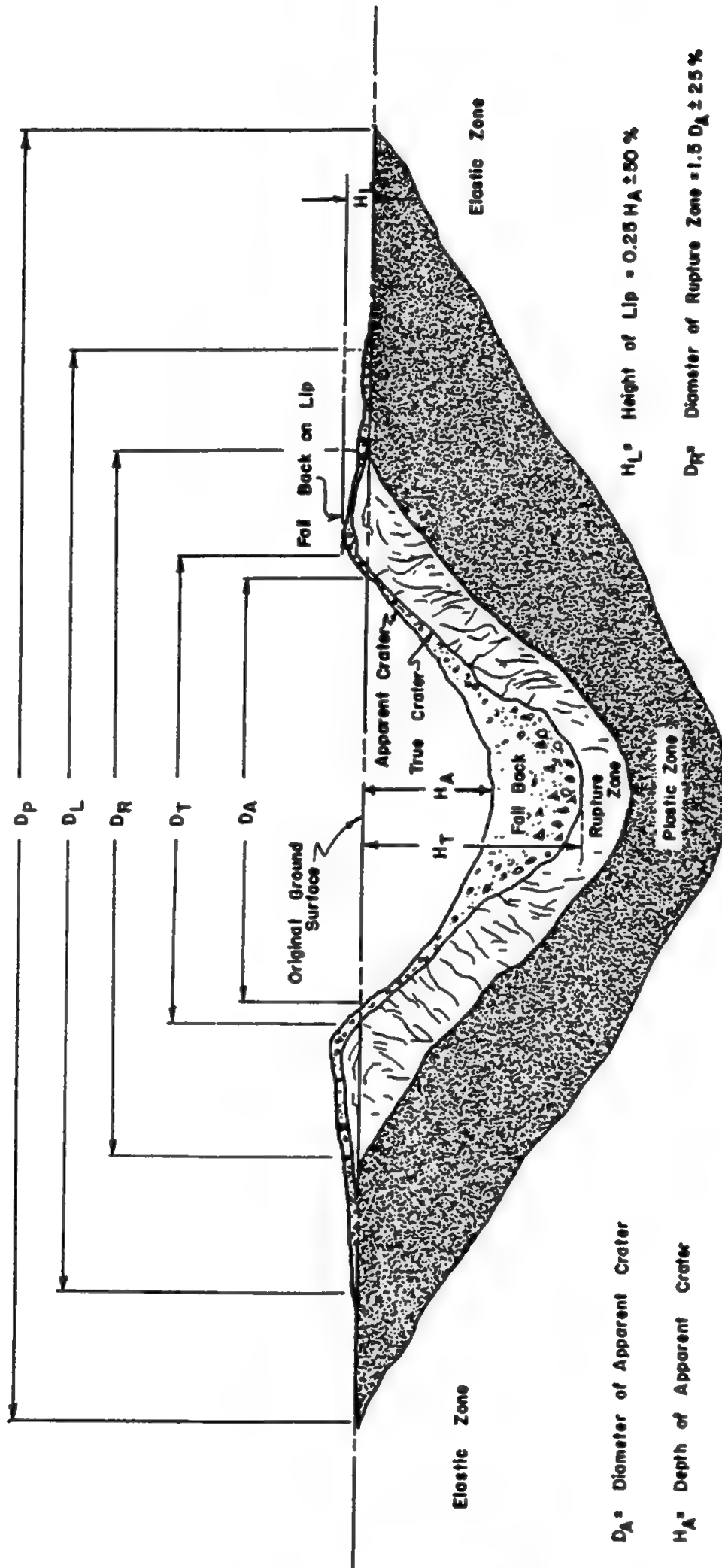

D_A = Diameter of Apparent Crater

H_A = Depth of Apparent Crater

D_T = Diameter of True Crater

H_T = Depth of True Crater

D_L = Diameter of Lip = $2.0 D_A \pm 25\%$

H_L = Height of Lip = $0.25 H_A \pm 50\%$

D_R = Diameter of Rupture Zone = $1.5 D_A \pm 25\%$

D_p = Diameter of Plastic Zone = $3 D_A \pm 50\%$

V_C = Volume of Apparent Crater = $\frac{\pi D_A^2 H_A}{6}$
(Assumed Paraboloid)

depth, and lip height for a burst on the surface and on the bottom in 25, 50, 100, and 200 feet of water. The figures show that the crater dimensions are greater for a bottom burst than for a surface burst. Also for a bottom burst, as the depth of water increases the crater dimensions increase, whereas for a surface burst, as the water depth increases the crater dimensions decrease.

b. Ground Shock.

(1) *General.* The production of ground shock by nuclear explosions is extremely complex, and, in some respects, not well understood. Basically, ground shock may be produced by two separate mechanisms. One mechanism is the sudden expansion of the bubble of gas from a surface or underground explosion which generates a pulse or oscillation in the ground. This is termed "direct ground shock". As this direct shock propagates through the ground, it may be modified by reflections and refractions from underlying bedrock or hard strata, or rarefaction from the air-ground interface. The second mechanism is the production of a ground shock by the air blast wave from a nuclear explosion striking and moving parallel to the ground surface. This is termed "air induced ground shock." For a given burst geometry, except at extremely short ranges, these two forms of ground shock are separated in time. Because the direct ground shock is usually attenuated very rapidly, induced ground shock is more important from the point of view of damage to underground installations, except for extremely close ranges and for deep underground bursts. Figure 2-27A shows in schematic form the relation of these two phenomena in the case of a surface burst. Since sonic velocity is generally higher in ground than in the air, the direct ground shock is indicated as moving faster than the air blast, and consequently faster than the air induced ground shock. Although the direct

ground shock and the air blast of a surface or near-surface burst initially propagate approximately together, the velocity of the air blast decreases more rapidly with distance in the higher pressure region than the direct ground shock. Hence, the direct ground shock moves ahead.

Figure 2-27B shows the relation in idealized form of the vertical acceleration caused by the two different forms of ground shock. The direct vertical acceleration is initiated upon arrival of the direct ground shock. The "air blast slap acceleration" is initiated upon the arrival of the air blast which causes a sudden local increase in soil particle acceleration.

The physical mechanisms of major interest in regard to the production of ground shock damage are acceleration, displacement and pressure (or stress). Although extensive measurements have been made, no consistent correlation between these parameters has been found. Each is discussed for both direct ground shock and air induced ground shock in the following paragraphs.

(2) *Direct ground shock.*

(a) *Propagation.* The direct ground shock wave produced by a surface or underground burst propagates radially outward from the burst point. For a 1 KT surface or shallow underground burst, in Nevada type soil, propagation velocities on the ground surface are 4,600 feet per second approximately 300 feet from surface zero, and decrease to a more constant 3,500 feet per second approximately 2,500 feet from surface zero. The propagation velocity of ground shock at the surface may increase with distance from the burst due to refraction and reflection from underlying higher velocity strata; and, as the shock reduces to an acoustic wave, the velocity will approach the normal acoustic velocity of the medium near the surface. In sound rock and outside the zone of rupture, the propagation of shock obeys elastic formulae.

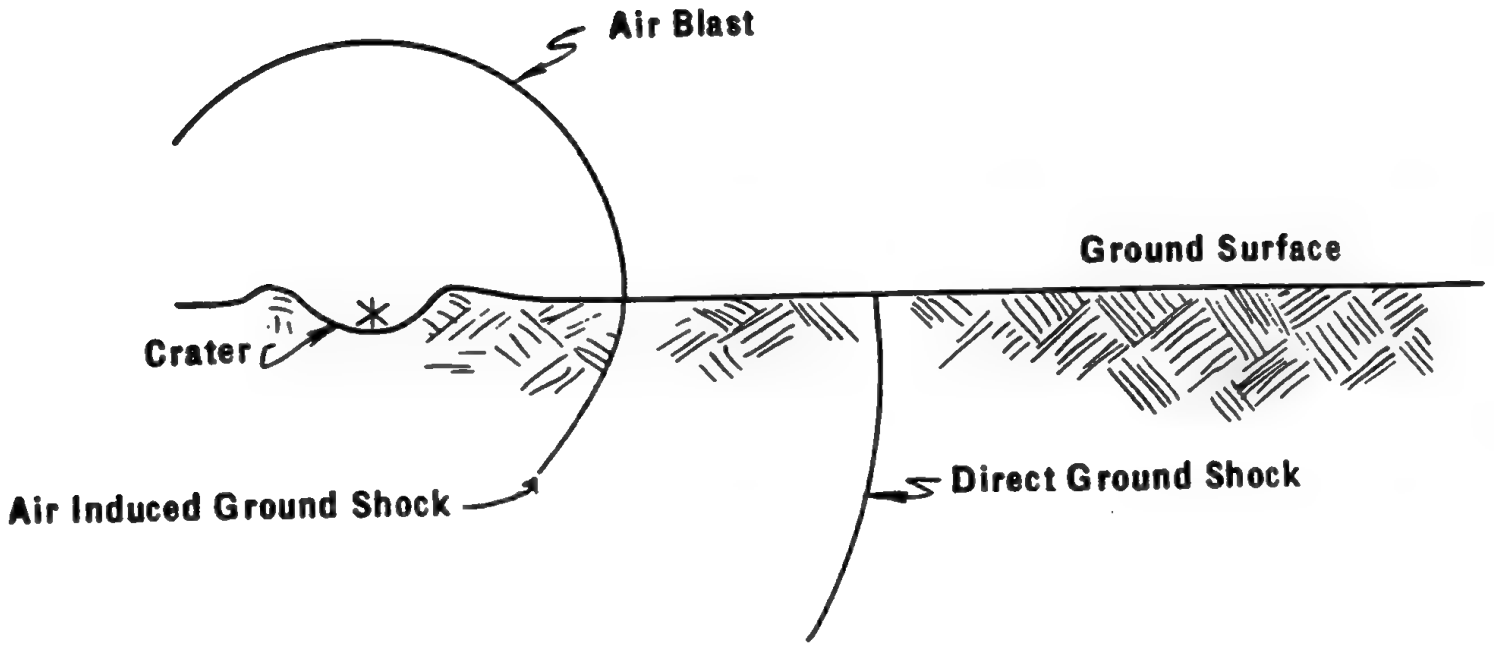

**DIRECT AND AIR INDUCED GROUND SHOCK
GROUND ACCELERATION WAVE FORM WITH "SLAP"**

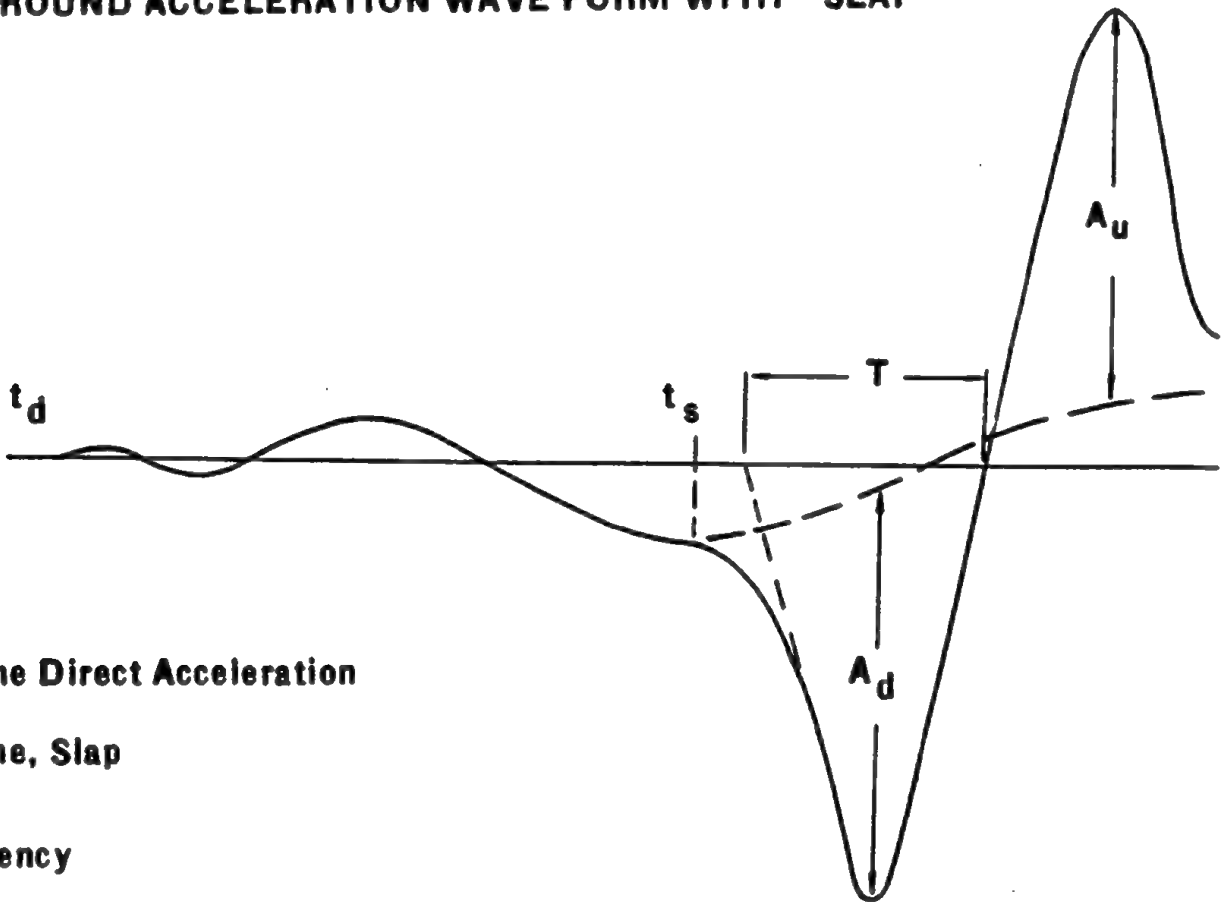

t_d = Arrival Time Direct Acceleration

t_s = Arrival Time, Slap

$\frac{1}{2T}$ = Slap Frequency

A_d = Max. Downward Slap Acceleration

A_u = Max. Upward Slap Acceleration

In such a homogeneous medium (not generally characteristic of surface conditions), there is little attenuation due to internal friction or plastic deformation. Ground shock (compression type wave) in rock is reflected from an air-rock interface as a tensile wave. The intensity of this tensile wave is dependent on shock strength, wave shape, and angle of incidence of the direct shock with the free surface.

- (b) *Pressure (stress)*. At any given point air blast or water shock overpressures resulting from a nuclear detonation are equal in all directions, but ground pressures are not. The shear and cohesive strength of the soil change the ground pressure into directional components which differ in magnitude depending upon the direction in which measured. These directional pressure components are termed stress. Under the dynamic loading from a nuclear explosion, the direct ground stresses rise most abruptly in the ground nearest the explosion, whereas at greater distances the peak stresses at any specific point are reduced and the rise times are increased. Stress pulses appear as various combinations of direct ground and air induced shock stresses, depending on arrival time and the range, depth and direction of the measurement. Direct and air induced ground shock stress pulses may coincide at close-in ranges outside the crater, as indicated in (1) above, but will gradually separate with increasing distance along the ground surface until two separate pulses may be detected a few feet beneath the ground surface. The peak stresses from direct ground shock usually attenuate rapidly with distance; however, in highly saturated soils the attenuation of these stresses is less, approaching the attenuation in water (approximately inversely as the range). The stress pulse from the direct ground shock is composed of vibrations of high and low frequencies,

the period of which may vary from a few tenths of a second to several seconds. Two hundred feet from a 1 KT underground burst in Nevada type soil, the horizontal earth stress at a depth of 10 feet may be 125 psi; at 250 feet it may be 40 psi; while at 600 feet it may be only 3 psi. A rough comparison of peak stress intensities for various yields at the same distances may be made on the basis of relative crater size.

- (c) *Acceleration of soil particles*. Acceleration of soil particles may be caused as a direct result of the explosion (direct acceleration), as a result of any shock reflection or refraction from underlying bedrock (indirect acceleration), or as a result of air blast (induced acceleration). Direct and indirect accelerations are generally indistinguishable and together are termed direct or fundamental acceleration. For acceleration values of 1 g or greater measured beyond a range of two crater radii from ground zero the frequency in soil will usually be less than 80 cycles per second for all yields, and for 1 KT the predominant frequencies will be from 3 to 15 cycles per second. In rock, the amplitude of accelerations may be considerably greater and the period may be less than in average soil.
- (d) *Displacement of soil particles*. Displacement of soil particles is largely permanent within the plastic zone of a crater and transient beyond the plastic zone. For a small, near-surface burst, and at a range of three crater radii, the permanent displacement along the ground surface will probably be less than 0.0003 of a crater radius and the transient displacement will probably be less than 0.001 of a crater radius. A short distance beneath the ground surface, soil particle displacement is usually less than the displacement along the ground surface. Displacements are

appreciably affected by soil types. In wet soils, for example, they may be of the order of ten times greater than the preceding values.

(3) *Air induced ground shock.*

(a) *Propagation.* Air induced ground shock propagates outward from the burst with the air blast. The air blast loading may be considered as a moving, non-uniform load that generates a ground shock. The air induced shock in soil quickly attains a velocity that may exceed the air blast velocity; however, the magnitude of any out-running shock is small and its effects may be ignored. Consequently, as the air blast wave proceeds, the air induced ground shock propagates with a rather complex underground time-of-arrival contour depending on underground shock velocities; but, in general, the ground shock front slopes backward from the air blast shock front as shown in figure 2-27A. Air induced ground shock usually arrives with or after the direct ground shock.

(b) *Pressure (stress).* Air induced ground stress (pressure) is closely related to direct ground stress (pressure) discussed in (2)(b) above. Just below the surface, the air induced shock stresses and durations are approximately equal to the changing positive air blast pressure and duration. These induced ground stresses attenuate gradually with depth and the rise time of the stress pulse increases. The pulse of the air induced ground stress is composed of vibrations of high and low frequencies, the periods of which may vary from a few tenths of a second to several seconds. In general, air induced ground stress is larger than direct ground stress at distances greater than two crater radii for average soils, and for all heights and depths of burst down to about 75 feet for 1 KT.

(c) *Acceleration of soil particles.* Air blast induced acceleration maintains its identity in the acceleration pattern and can

be separated from the direct shock acceleration. When interactions with other accelerations from reflection and refraction occur, the magnitude is affected markedly and separation is difficult. Upon its arrival, the air blast will cause a sudden local increase in soil particle acceleration termed "air blast slap acceleration" (see fig. 2-27B). For acceleration values of 1 g or greater measured away from ground zero, the predominant frequencies in soil of air blast induced acceleration are 20 to 120 cycles per second. Peak vertical accelerations are larger than peak horizontal (radial) accelerations by an amount approximating 50 percent. Peak accelerations attenuate with depth and are directly proportional to the overpressure and indirectly proportional to the rise time of the pressure pulse in the soil. See figure 2-28 for the relationship of peak accelerations to peak air blast overpressures at a depth of 10 feet.

(d) *Displacement of soil particles.* Air induced ground shock causes little permanent horizontal displacement of ground particles beyond two crater radii. When the shock is reflected from vertical soil-air interfaces, local displacement (spalling) of ground particles may occur. Air induced ground shock may cause a vertical displacement of soil particles. Dry Nevada type soil subjected to a peak overpressure of 250 psi has sustained a permanent downward displacement of approximately 2 inches and a transient downward displacement of approximately 8 inches.

c. Column and Base Surge. A general discussion of the column and base surge resulting from an underground burst has been given in paragraph 1.4e(4). The maximum column diameter is generally 2 to 3 times the apparent crater diameter and the maximum column height is roughly equal to $400 W^{1/3}$. The characteristics of the base surge depend upon the depth and yield of burst. The shallowest burst depth at which an earth base

FIGURE 2-30

EFFECT OF CUT-OFF ON THE SHAPE OF THE POSITIVE PULSE

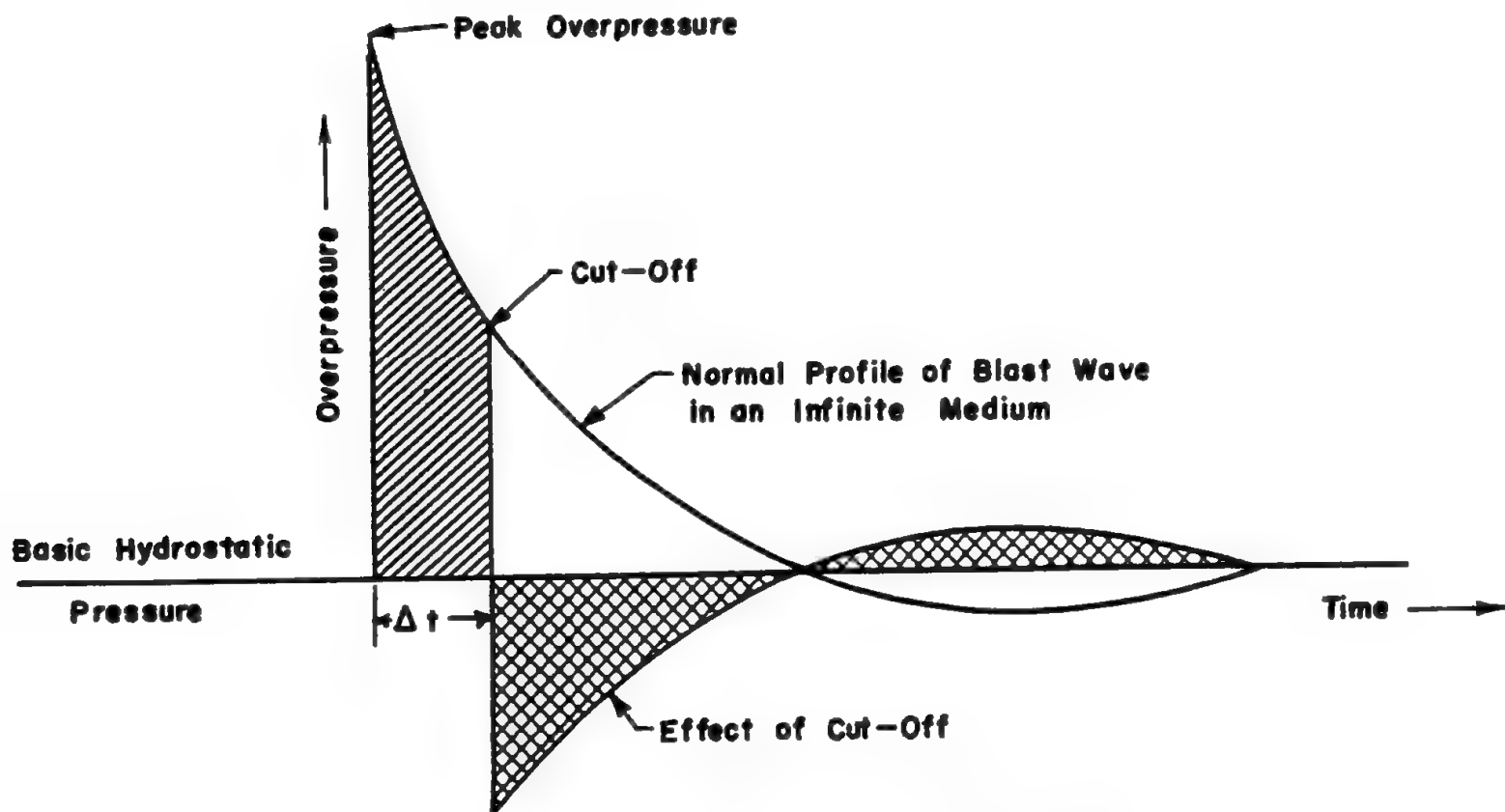

$$(\Delta t \text{ in msec}) = \frac{0.4 \times (\text{Bomb Depth in Ft}) \times (\text{Target Depth in Ft})}{\text{Slant Range in Ft.}}$$

surge has been observed is $16 W^{1/3}$ feet. As the burst depth is increased, the extent of the base surge is expected to increase until a burst depth of about $125 W^{1/3}$ feet is attained. No further increase in base surge extent is expected below this depth of burst. Figure 2-29 shows the rate of growth of the base surge and maximum radii for various scaled depths of burst.

2.3 Water Shock and Surface Phenomena

a. Water Shock.

(1) *General.* The underwater detonation of a nuclear weapon at a distance from either the water surface or the bottom boundaries produces a shock wave early in the formation of the bubble. This shock wave propagates spherically at the rate of roughly 5,000 feet per second, and is characterized by an instantaneous rise in pressure followed by an exponential decay. In addition to this initial primary shock wave, several subsequent pressure pulses are produced within the water (see par. 1.4f(2) and (3)).

(2) Burst geometry.

(a) *Deep burst in deep water.* When the pressure wave is reflected from the water surface it is reflected as a rarefaction or tensile wave. This reflected rarefaction wave cuts off the tail of the primary compressional shock wave, thereby decreasing the duration of its positive phase. Figure 2-30 shows qualitatively the effect of the reflection wave upon the pressure-time history. The effect of this "cut-off" decreases rapidly with depth of the target in the water; that is, the deeper a target, the less the effect of cut-off for the same depth of detonation. Likewise, the greater the depth of detonation, the less the effect of cut-off for the same target location. The reflection of pressures from the bottom surface is similar to the reflection of pressures from the ground surface for an airburst. A crude approximation of the magnitude and shape of this

WAVE FRONT PROPAGATION IN SHALLOW WATER

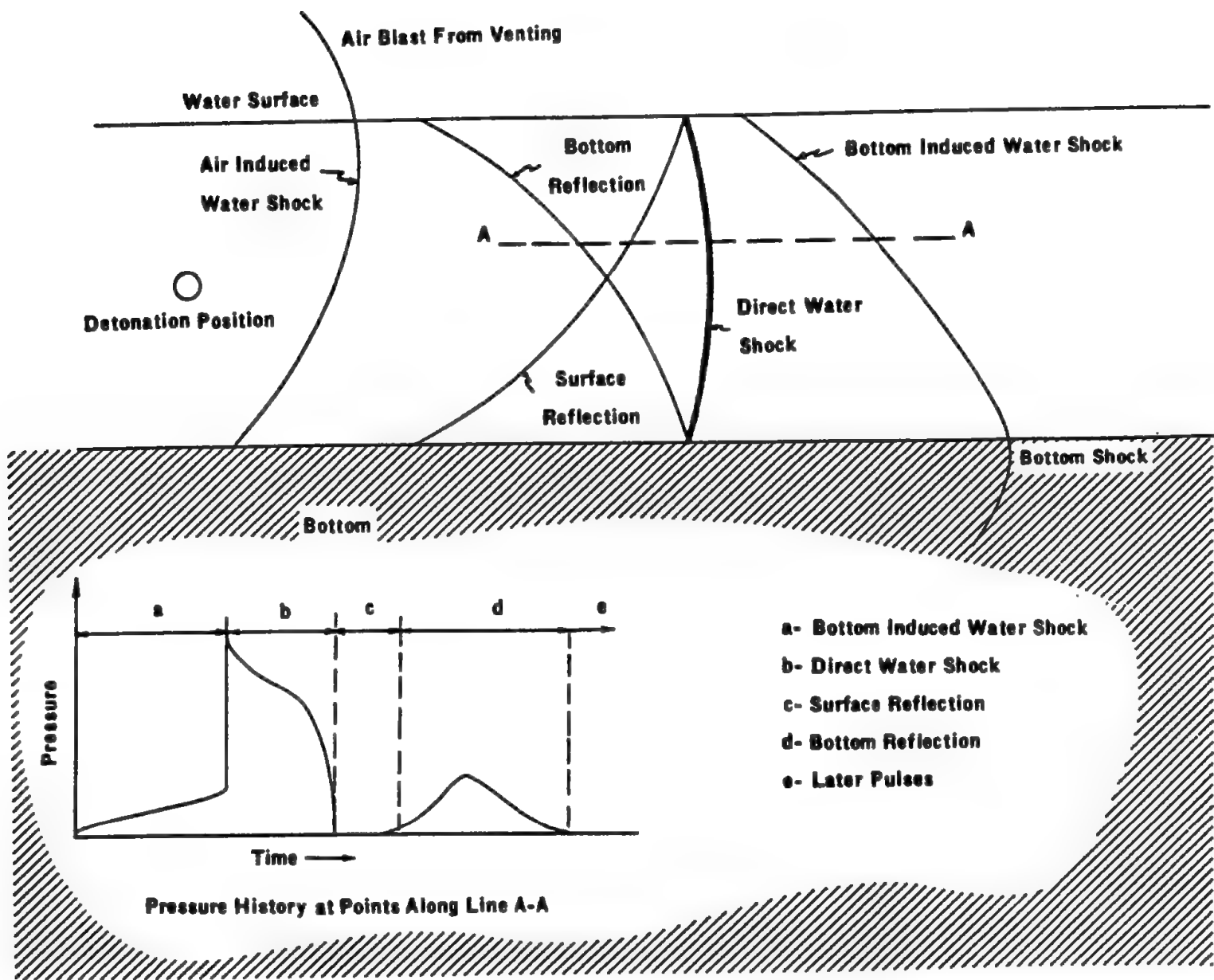

BAKER mately 1,000,000 tons of water were thrown into the air. As the column fell back into the water, there developed on the surface, at the base of the column, a large doughnut-shaped cloud of dense mist. This cloud, called the base surge, formed about 10 seconds after detonation and traveled rapidly outward at an initial velocity greater than 100 feet per second, maintaining an ever-expanding doughnut-shaped form. In the first 100 seconds, the average velocity was 63 feet per second. In 180 seconds, the surge traveled 8,100 feet.

(2) *Deep burst.* If the detonation is at a depth such that the bubble goes through several oscillations prior to venting, a bushy, ragged plume-like mass of water is thrown into the air by the emerging bubble (see fig. 1-6). The collapse of these plumes generates the base surge. For this deep burst, the first visible surface phenomenon was a very flat spray dome some 7,000 feet in radius and 170 feet in height. Three seconds later a second spray dome emerged out of the first, sending spikes to a height of 900 feet. At 10 seconds the plumes appeared, reaching a height of 1,450 feet and a diameter of 3,100 feet. As the plumes collapsed, a base surge spread out laterally to a cross wind radius of 4,600 feet at 90 seconds and approximately 7,000 feet at 15 minutes.

(3) *Intermediate depths.* At intermediate depths of burst, such that the bubble vents after the first expansion is com-

pleted but before several oscillations are completed, the magnitude of the base surge varies in a manner dependent upon the phase of the bubble at venting, together with the motion of the water surrounding the bubble at venting. When the bubble vents in an expanding phase the surge phenomenon is similar to that described for a shallow burst. When the bubble vents in a contracting stage, a tall spire of water is jetted into the air. The base surge resulting therefrom is less dense and of a smaller final radius. However, lack of knowledge of bubble behavior permits only a coarse prediction of the maximum size of base surge.

(4) *Growth.* Figure 2-35A gives the radius of the base surge as a function of time for a 1 KT yield at various depths of burst. Figure 2-35B gives the maximum radius of base surge as a function of yield for several specific depths of burst. Winds cause the surge to travel faster in the direction in which the wind is blowing. Although relative humidity does not affect the initial formation of the base surge, it does influence its subsequent growth and duration. When the relative humidity is significantly less than 70 percent, the extent and duration of the base surge are apt to be less than predicted. A significant increase in extent and duration of the base surge is expected when the relative humidity is appreciably greater than 70 percent.

WIGWAM

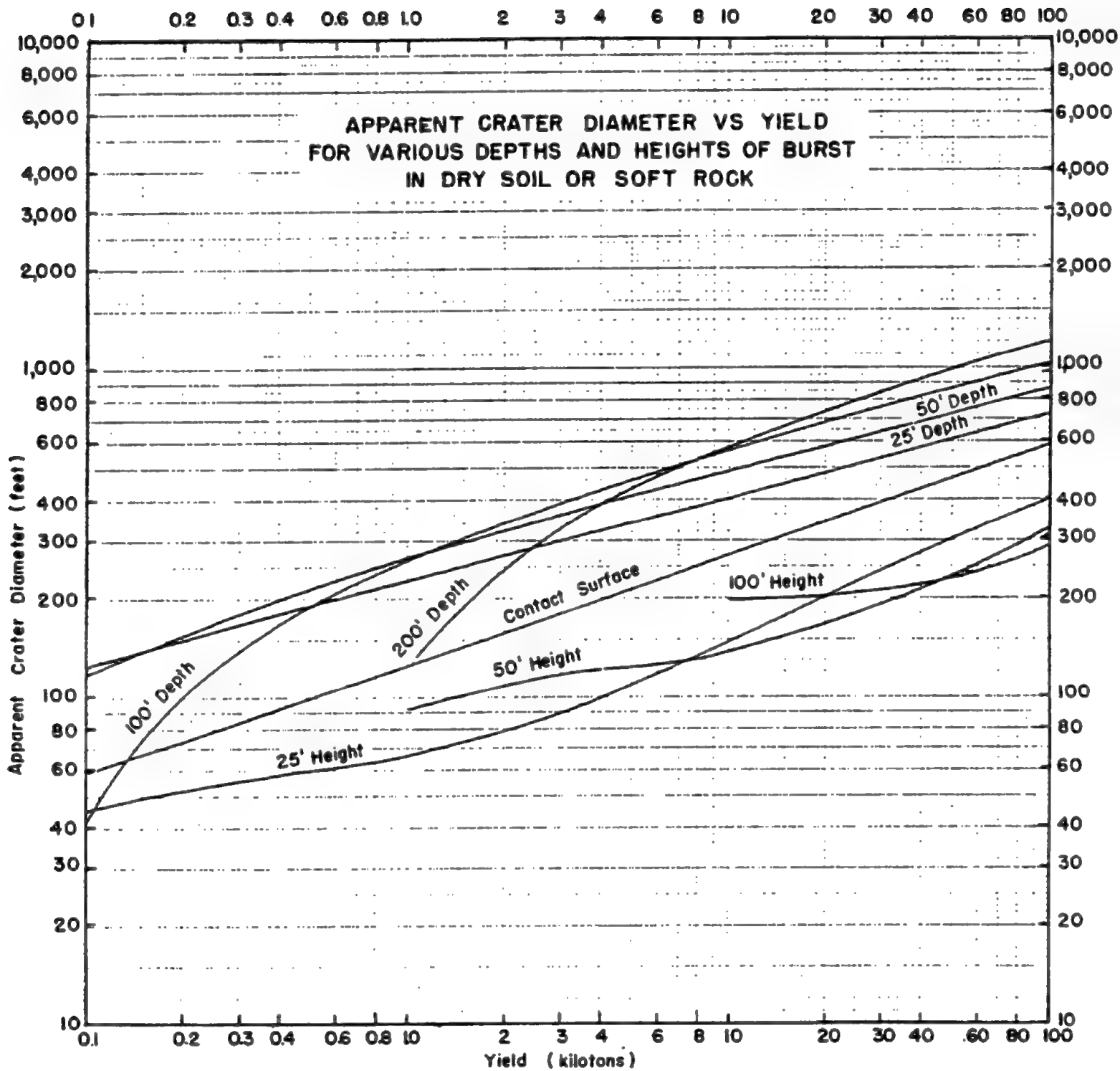

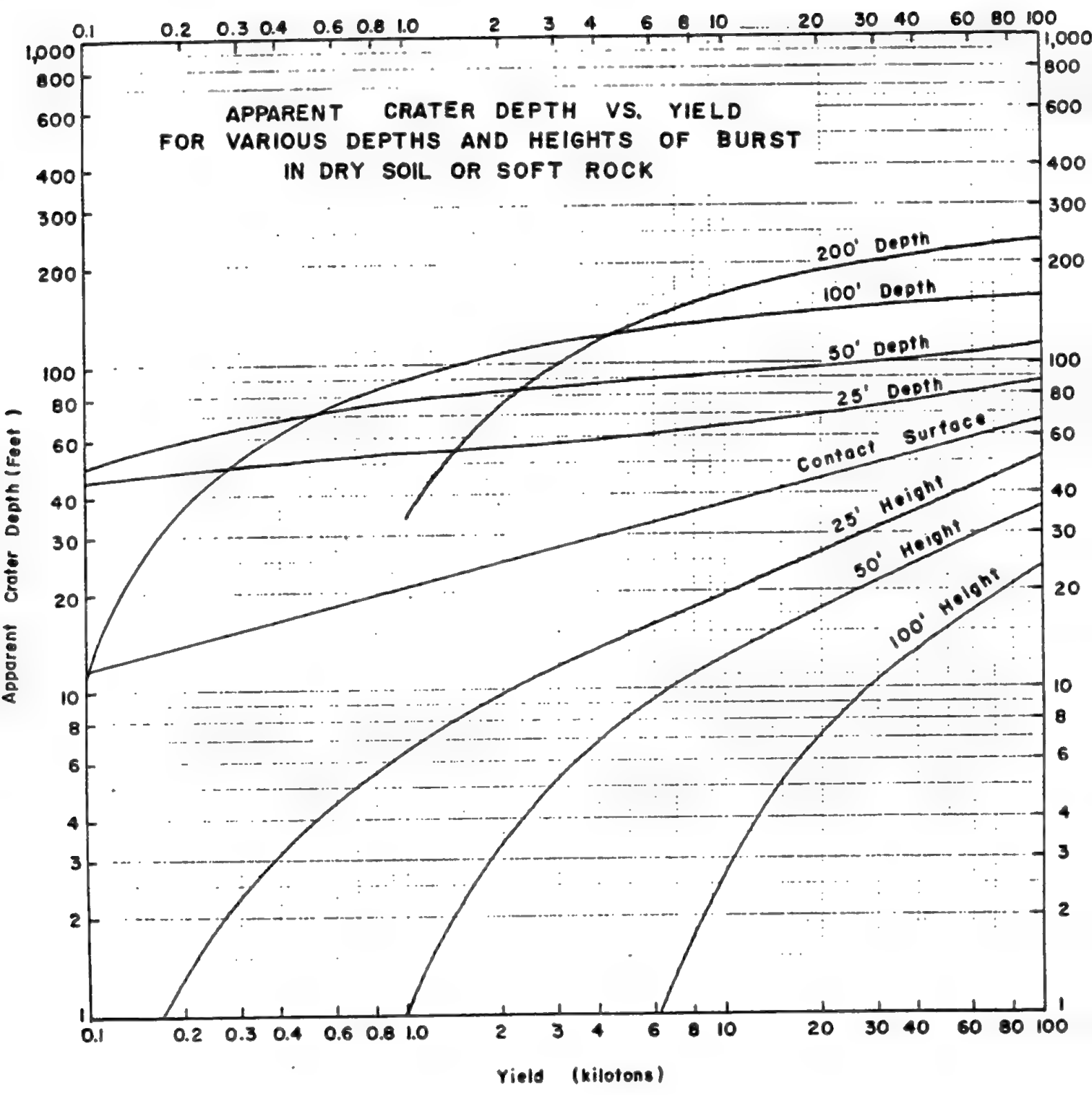

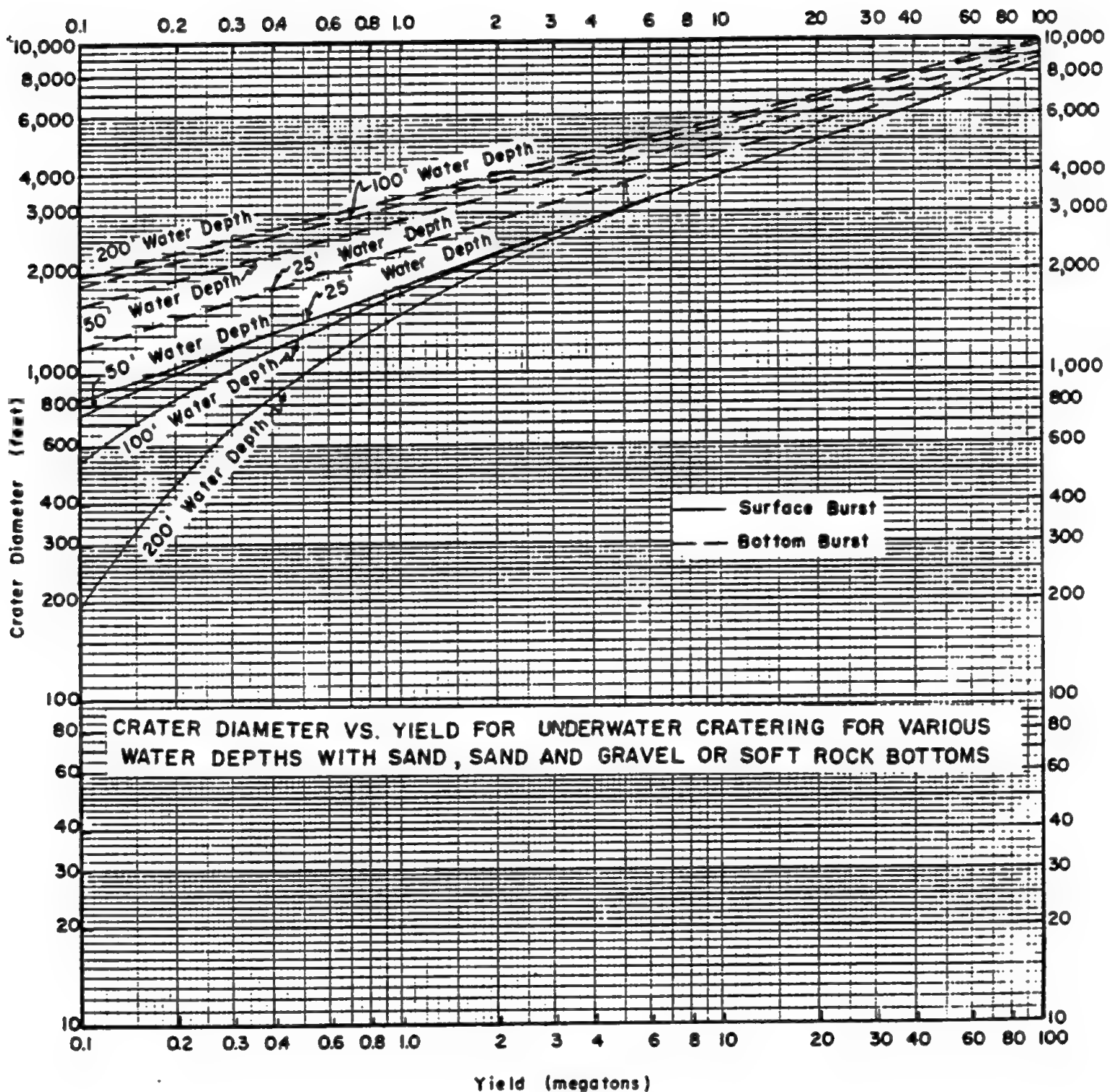

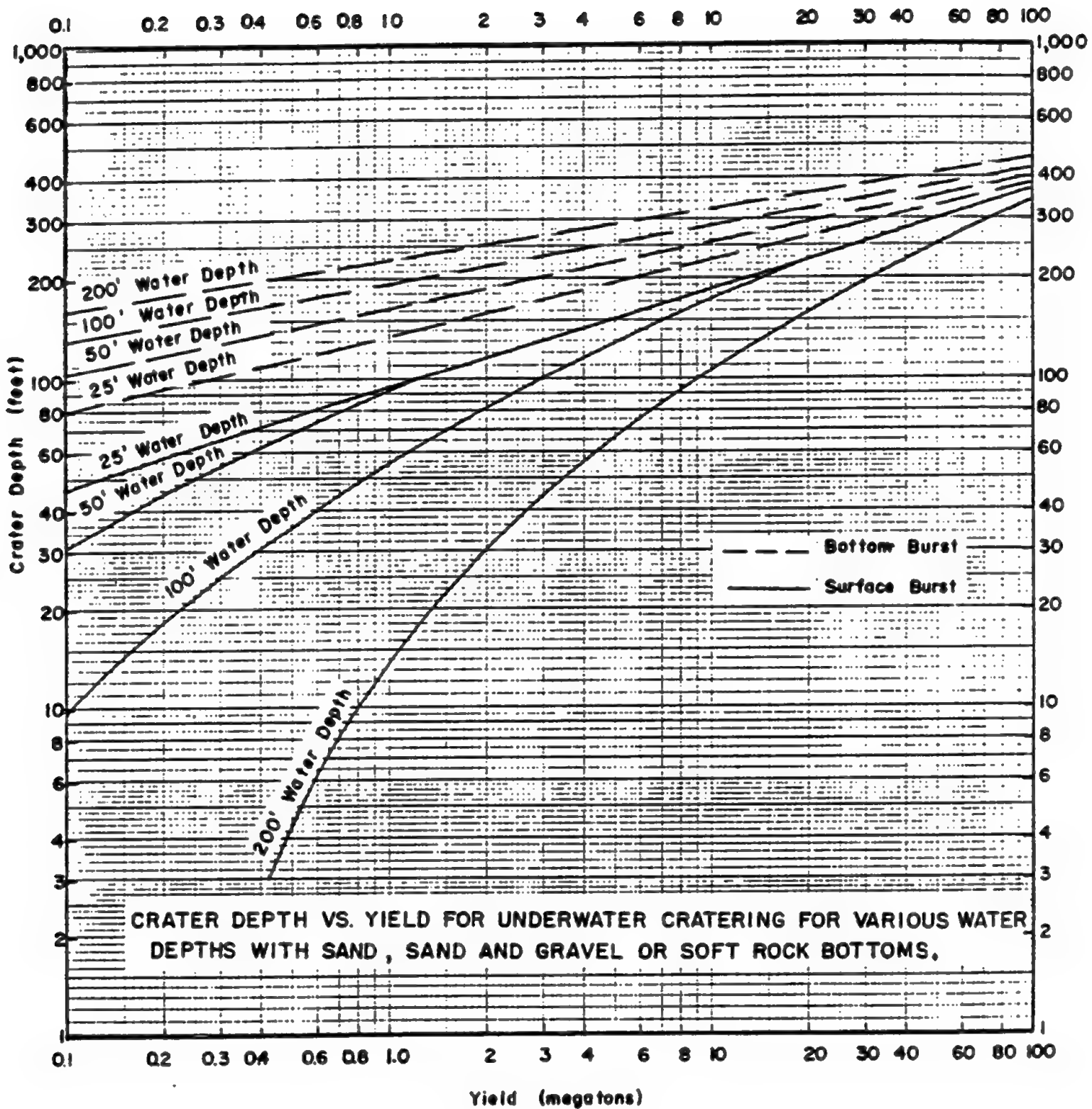

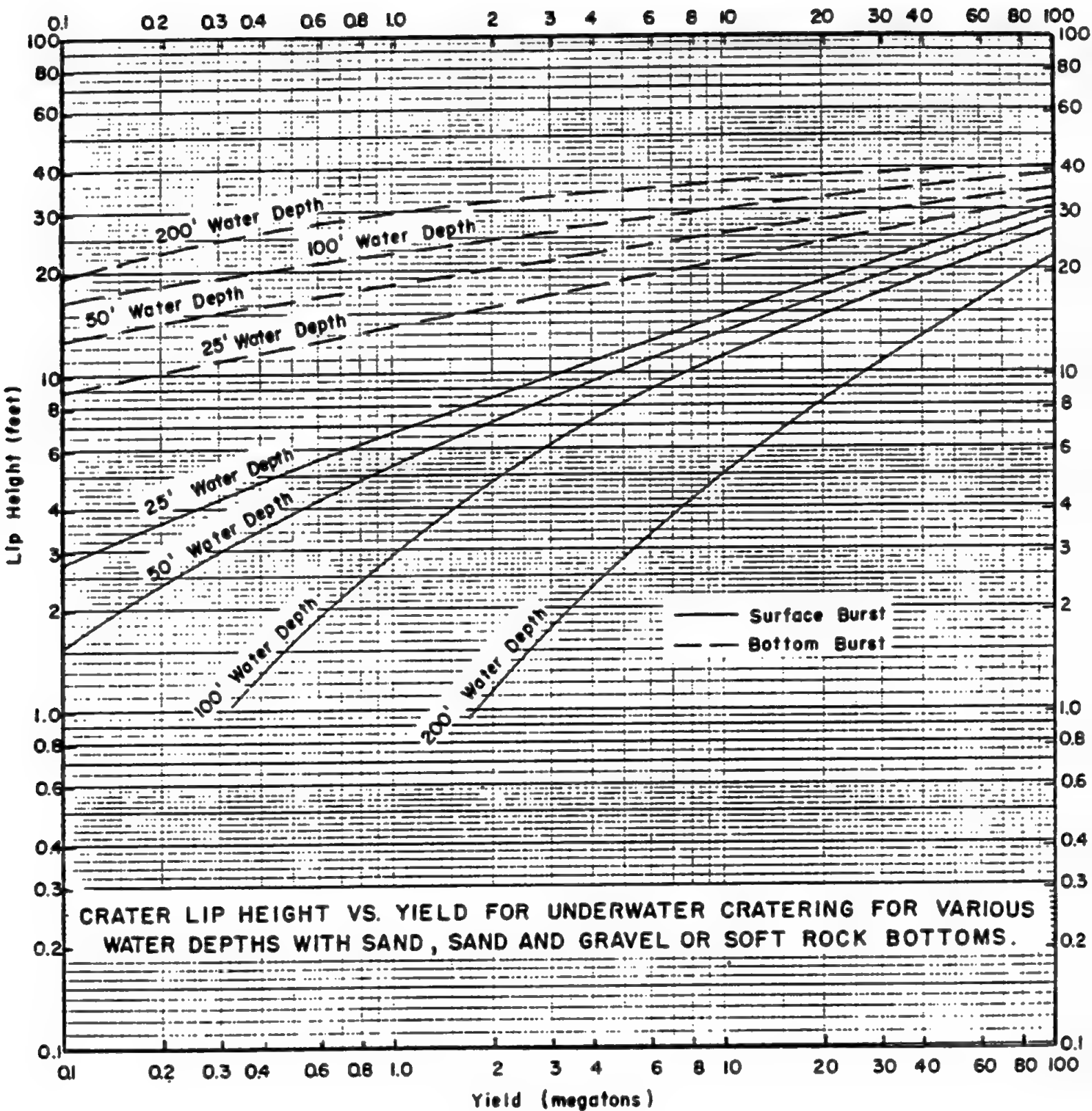

PEAK AIR BLAST INDUCED GROUND ACCELERATION (VERTICAL COMPONENT) VS. PEAK OVERPRESSURE

Figure 2-28 represents the relationship between overpressure and air blast induced ground acceleration. The acceleration shown is the maximum vertical acceleration (upward or downward) measured at a depth of approximately ten feet below the horizontal ground surface in Nevada type soil. Horizontal acceleration can be assumed to be approximately equal to 70 percent of the vertical acceleration. Accelerations measured at a depth of 5 feet may be roughly 150 percent of those indicated and accelerations measured at a depth of twenty feet may be roughly 50 percent of those indicated. Mediums denser than Nevada type soil may experience higher acceleration values and less dense mediums may experience less acceleration. The accelerations shown are applicable only to regions beyond the plastic zone of any crater produced.

Procedure. To determine the acceleration at any range, determine the peak overpressure at that range from figure 2-9 or figure 2-10, which-

ever is applicable, and read the acceleration directly from the curve.

Example.

Given: An 80 KT detonation at a height of burst of 2,580 feet over an "average" surface.

Find: The vertical ground acceleration at a range of 4,000 yards, 10 feet below the ground surface.

From figure 2-10B the overpressure from an 80 KT burst at 4,000 yards is 3 psi. Reading directly from figure 2-28, the acceleration is 0.2 g. *Answer.*

Reliability. The curve is based on full scale field tests in Nevada type soil. Accelerations obtained from the curve may be high by a factor of two or low by a factor of three even in Nevada type soil. When applied to other soils, the reliability of the curve is reduced.

Related material.

See paragraph 2.2b.

PEAK AIR BLAST INDUCED GROUND ACCELERATION VERTICAL COMPONENT Vs. PEAK OVERPRESSURE

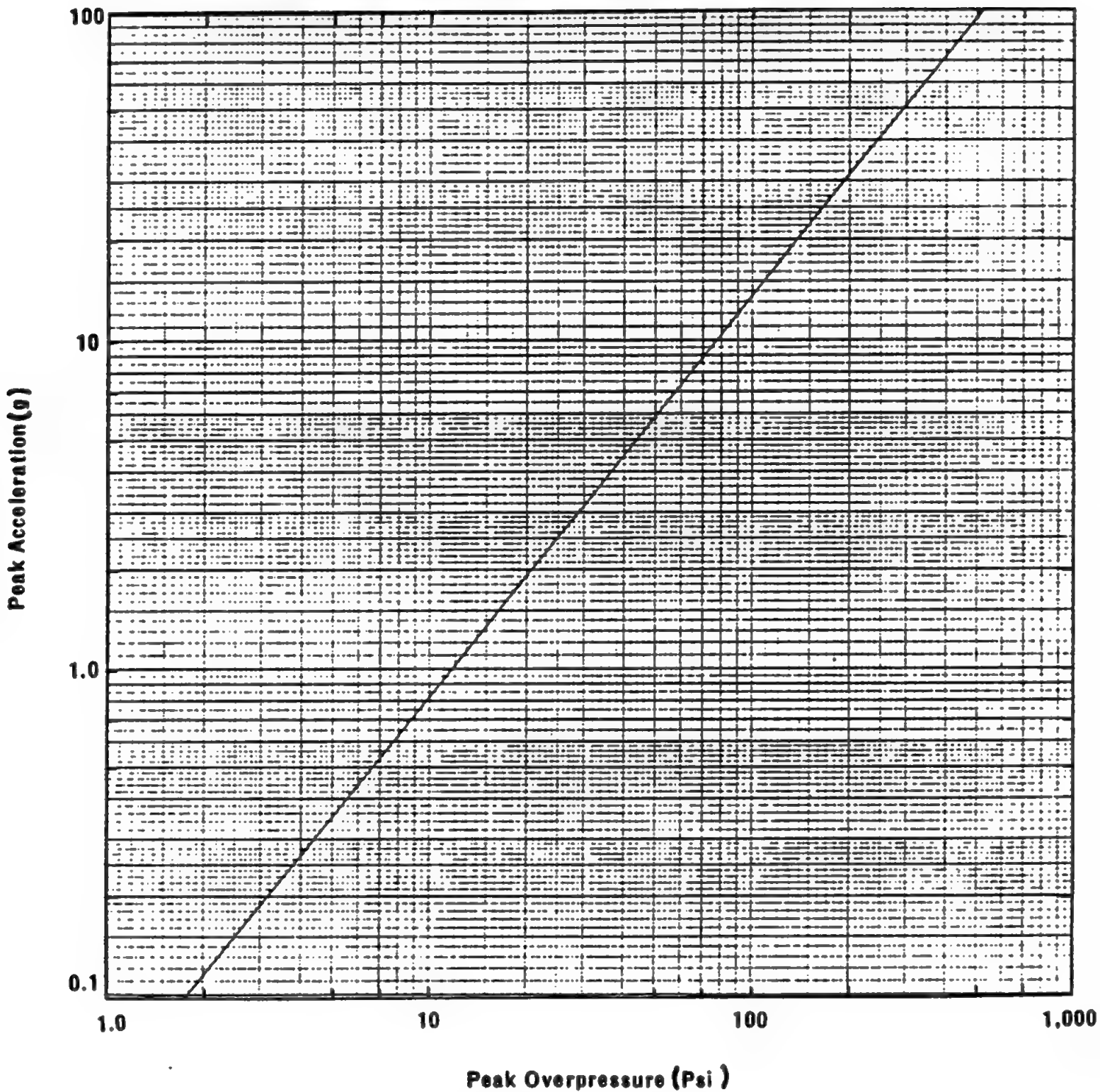

BASE SURGE FOR UNDERGROUND BURSTS

Figure 2-29A gives the expected rate of radial growth of the earth base surge from a 1 KT underground burst; figure 2-29B gives the expected maximum base surge radius vs. yield. Figure 2-29B is based on extrapolation from the maximum base surge radii of the curves in figure 2-29A. Radii obtained from the figures assume no wind, or are crosswind radii. To compute *upwind* or *downwind* base surge radii at a specific time after detonation, add the distance traversed by the wind up to this time to the base surge radius obtained from the figures to obtain the downwind base surge radius, or subtract to obtain the upwind base surge radius.

Scaling. Depth of burst and the maximum radius of the base surge scale as the cube root of yield between scaled depths of burst of 16 $W^{1/3}$ and 125 $W^{1/3}$ feet, or:

$$\frac{h_1}{h_2} = \frac{r_1}{r_2} = \frac{W_1^{1/3}}{W_2^{1/3}}$$

where h_1 and r_1 are depth of burst and base surge radius for yield W_1 , and h_2 and r_2 are the corresponding depth of burst and base surge radius for yield W_2 .

Time to complete a given percentage of total radial growth of base surge scales as the one-sixth power of the yield for the same scaled depth of burst, or:

$$\frac{t_1}{t_2} = \frac{W_1^{1/6}}{W_2^{1/6}}$$

where t_1 = time to complete a given percentage of total radial growth for yield W_1 , and t_2 = corre-

sponding time to complete the same percentage of total radial growth for yield W_2 .

Example.

Given: A 64 KT detonation 65 feet underground.

Find:

- (a) The maximum base surge radius.
- (b) The time at which the maximum radius occurs.

Solution: The corresponding depth of burst for 1 KT is:

$$h_1 = \frac{W_1^{1/3} \times h_2}{W_2^{1/3}} = \frac{1 \times 65}{(64)^{1/3}} = 16 \text{ ft.}$$

From figure 2-29A the maximum radius for 1 KT at a 16 foot depth of burst is 2,010 feet and occurs at 180 seconds.

The corresponding radius for 64 KT is:

$$r_2 = \frac{r_1 \times W_2^{1/3}}{W_1^{1/3}} = \frac{2,010 \times (64)^{1/3}}{1} = 8,040 \text{ ft. } \textit{Answer.}$$

This may also be read directly from figure 2-29B.

The time at which this maximum radius occurs is—

$$t_2 = \frac{W_2^{1/6} \times t_1}{W_1^{1/6}} = \frac{(64)^{1/6} \times 180}{1} = 360 \text{ sec. } \textit{Answer.}$$

Reliability. The data presented in the figure are based on limited full scale testing and extensive HE reduced scale testing.

Related material.

See paragraphs 1.4e(4) and 2.2c.

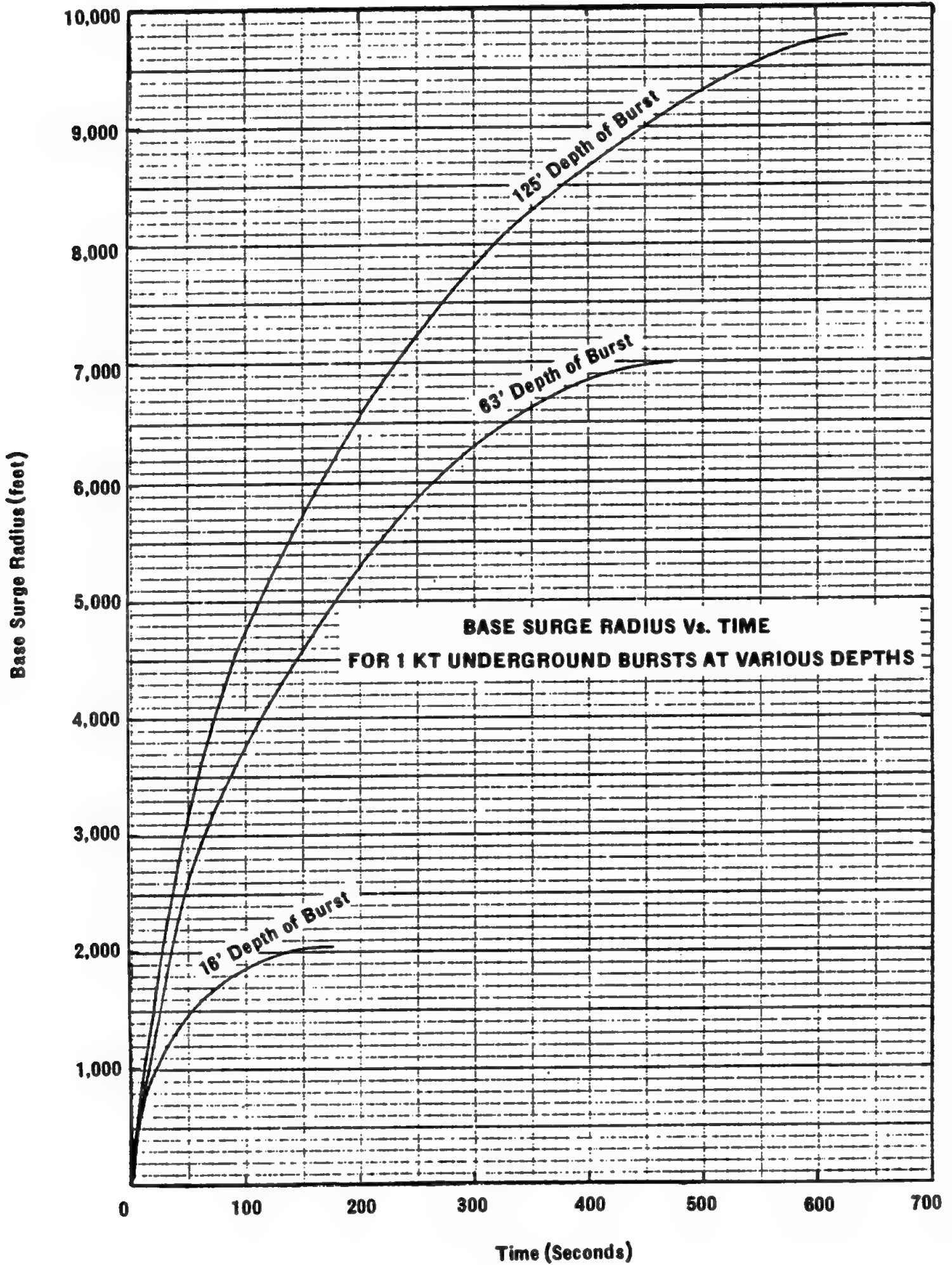

BASE SURGE FOR UNDERWATER BURSTS

Figure 2-35A gives the expected radial growth of the water base surge as a function of time after detonation for a 1 KT weapon at various depths of burst. Figure 2-35B gives the expected maximum base surge radius as a function of yield for several specific depth of burst conditions. The maximum base surge is developed from a weapon detonated at approximately the venting depth (250 $W^{1/4}$ ft.). For very shallow depths of burst, less than 10 $W^{1/3}$ feet, the occurrence of a base surge is improbable. Proximity of the bottom to the point of detonation has little effect upon the production of the base surge. For depths of burst between the limits 10 $W^{1/3}$ and 250 $W^{1/4}$ feet, the diameter of the water column producing the base surge is approximately one fourth of the resultant surge radius. With depths of burst below the venting depth of 250 $W^{1/4}$ feet, no such simple relation of the column or plume to the resultant surge exists. Little data or theory is available for base surge predictions at deep depths. A prediction can be made, however, by linear interpolation between the base surge radius of a burst at venting depth and one at a deep scaled depth (650 $W^{1/3}$ feet). A prediction thus made represents the maximum base-surge which could be expected.

Radii obtained from figures 2-35A and 2-35B assume "no wind" conditions. To compute upwind or downward base surge radii for a specific time after detonation, add the distance traveled by the wind up to this time to the "no wind" base surge radius to obtain the downwind base surge radius, or subtract to obtain the upwind base surge radius.

Scaling. Depth of burst and the accompanying maximum radius of the base surge scale as the cube root of yield for depths of burst between 25 $W^{1/3}$ and 250 $W^{1/4}$, or:

$$\frac{h_1}{h_2} = \frac{r_1}{r_2} = \frac{W_1^{1/3}}{W_2^{1/3}}$$

where h_1 and r_1 are depth of burst and base surge radius for yield W_1 , and h_2 and r_2 are the corresponding depth of burst and base surge radius for yield W_2 .

Time to complete a given percentage of total radial growth of the base surge scales as the one-

sixth power of the yield for the same scaled depth of burst, or:

$$\frac{t_1}{t_2} = \frac{W_1^{1/6}}{W_2^{1/6}}$$

where t_1 =time to complete a given percentage of total radial growth for yield W_1 , and t_2 =the corresponding time to complete the same percentage of total radial growth for yield W_2 .

Time to reach the maximum base surge radius from a detonation at venting depth or less may also be computed by:

$$t_{max} = 2.25r^{1/2}$$

where t_{max} =time to the maximum base surge radius in seconds,

and r =maximum base surge radius in feet.

Examples.

- (1) *Given:* A 10 KT detonation at a depth of 150 feet below the water surface.

Find:

- (a) The maximum base surge radius.
- (b) Time to maximum base surge radius.
- (c) The expected base surge radius 1 minute after detonation.

Solution:

- (a) The maximum base surge radius is read directly from figure 2-35B as 7,200 feet. *Answer.*

- (b) The venting depth is 250 $W^{1/4}$ =440 feet. Since the depth of burst is less than venting, the simplified formula for time to maximum may be used. The time of maximum base surge radius is $t_{max} = 2.25 (7,200)^{1/2} = 190$ seconds. *Answer.*

- (c) A 10 KT detonation of 150 feet depth will complete the same percentage of its total radial growth in 60 seconds as a 1 KT detonation will complete at a corresponding scaled time and depth. Using the scaling above, the corresponding depth of burst for 1 KT is—

$$h_1 = \frac{W_1^{1/3} \times h_2}{W_2^{1/3}} = \frac{1 \times 150}{(10)^{1/3}} = 70 \text{ ft.}$$

**BASE SURGE RADIUS Vs. TIME
FOR 1 KT UNDERWATER BURSTS AT VARIOUS DEPTHS**

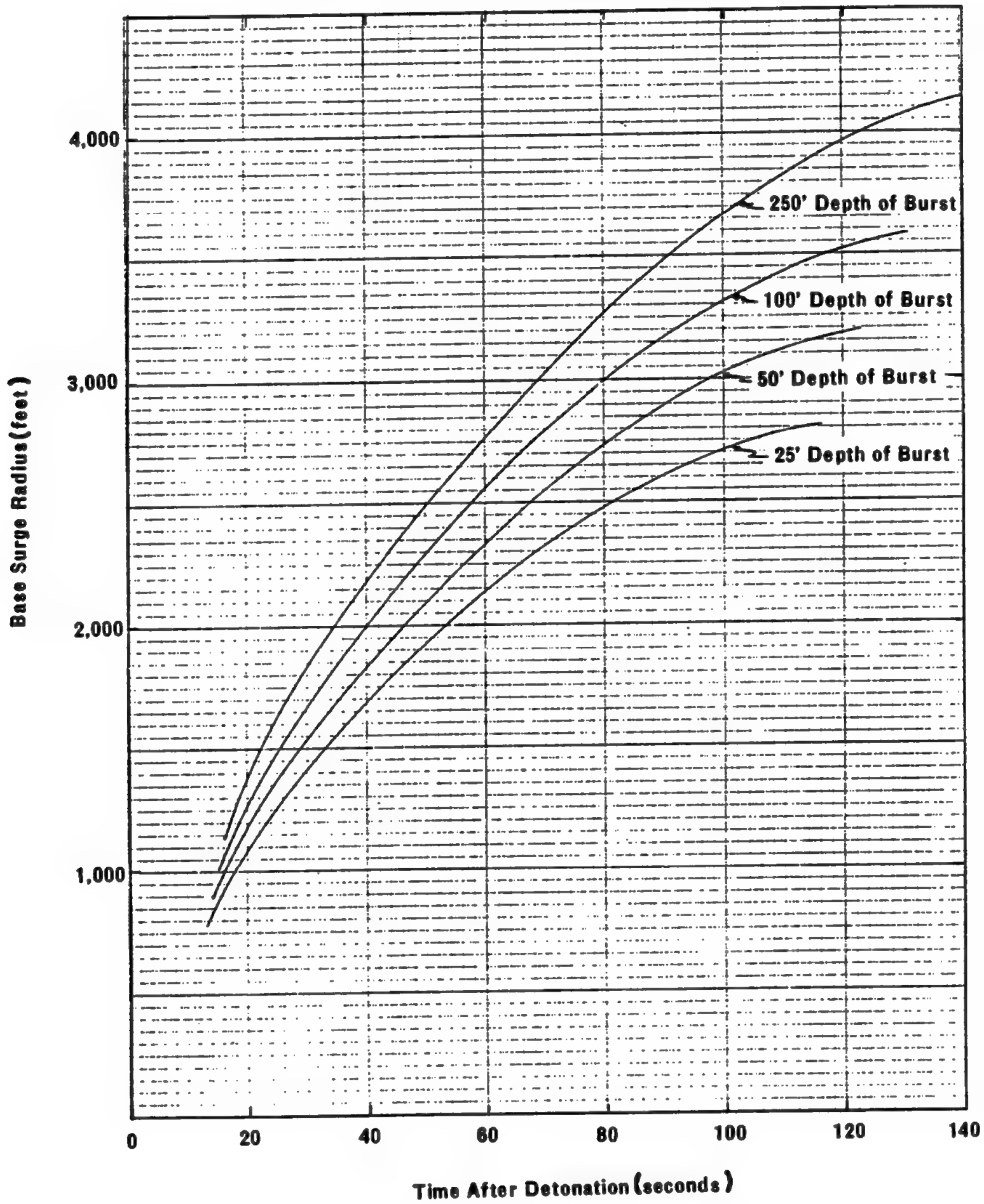

SECTION III

THERMAL RADIATION PHENOMENA

3.1 General

The extremely high temperatures in the fireball result in a large emission of thermal radiation. The relatively large fraction of the total energy of a nuclear detonation which is emitted as thermal radiation is one of its most striking characteristics. This radiant energy amounts to approximately one-third of the total energy of an air burst weapon; it is sufficient to cause serious burns to exposed personnel and to start fires in some combustible materials out to considerable distances. The duration of the thermal radiation emission depends upon the weapon yield, and is longer for the larger yields.

For a surface burst having the same yield as an air burst, the presence of the earth's surface results in a reduced thermal radiation emission and a cooler fireball when viewed from that surface. This is due primarily to heat transfer to the soil or water, the distortion of the fireball by the reflected shock wave, and the partial obscuration of the fireball by dirt and dust (or water) thrown up by the blast wave.

In underground bursts the fireball is obscured by the earth column, and therefore thermal radiation effects are negligible. Nearly all of the thermal radiation is absorbed in fusing and vaporizing the earth.

Thermal radiation from an underwater detonation is increasingly absorbed in vaporization and dissociation of the surrounding medium as the depth of burst is increased. Its direct effects are insignificant for most practical purposes; e. g., for a 20 KT burst in ninety feet of water, thermal effects are negligible.

3.2 Thermal Scaling

a. General. In paragraph 1.4b(2) the fireball was described as emitting thermal radiation in a pulse characterized by a rapid rise to a first maximum, a decline to a minimum, another rise to a second maximum and a subsequent final decline.

The first phase of this pulse occurs so very rapidly that less than 1 percent of the total thermal radiation is emitted. Consequently, it is the second phase of the pulse which is of interest in weapons effects considerations at altitudes in the lower troposphere.

Throughout, the fireball may be considered to radiate essentially, though not ideally, as a black body, for which the radiant power is proportional to the radiating area and the fourth power of the temperature. After the minimum the radiating radius and area increase relatively slowly, so that the radiant power is predominately determined by the temperature cycle of the fireball. An illustration of the apparent temperature and fireball radius versus time for a 20 KT air burst is shown in figure 3-1. It should be emphasized, however, that the actual radiating area may vary substantially from that of the luminous fireball. Very little quantitative information is available concerning the rate of growth of the fireball following the time at which "breakaway" occurs (approximately 0.015 second for the 20 KT burst shown in figure 3-1). Up to the time of breakaway, however, the radius increases approximately as the 0.4 power of the time after detonation.

b. Thermal Pulse. The shape of the pulse after the radiant power minimum (t_{min}) is sufficiently similar for nuclear detonations that a single curve may represent the time distribution of radiant power emitted (fig. 3-2). This curve has been developed by using ratios. The ratio p/p_{max} is plotted against the ratio t/t_{max} , where p/p_{max} is the ratio of the radiant power at a given time to the maximum radiant power, and t/t_{max} is the ratio of time after detonation to the time to the second thermal maximum for that detonation.

The percent of the total thermal radiation emitted versus the ratio t/t_{max} is also shown on figure 3-2. From this figure it is seen that approximately twenty percent of the total emission occurs up to the time of the second power maxi-

imum, whereas approximately 82 percent is emitted prior to 10 times the time to the second maximum. By this time the rate of delivery has dropped to such a low value that the remaining energy is no longer of significance in damage production.

c. Time scaling. It has been found that both the time to the minimum and the time to the second maximum are proportional to the square root of the weapon yield. Thus, for airbursts at altitudes of burst below about 50,000 feet, the time to the minimum (t_{\min}) is $0.0027 W^{1/2}$ second. The time to the second maximum (t_{\max}) is $0.032 W^{1/2}$ second. (See figures 3-3A and 3-3B. These curves may also be used for surface bursts.) It should be noted that for weapon yields lower than 6 KT the actual values of t_{\max} may be as much as 30 percent higher than those given by figure 3-3A. This is caused by the higher mass-to-yield ratio characteristic of low yield weapons. These relations indicate that a one megaton weapon delivers its thermal radiation over a period 32 times as great as does a one kiloton weapon. This can be expected to result in variations in total thermal energy required for a given effect. The significance of the dependence of delivery rate on weapon yield is discussed in the sections dealing with thermal injury and damage.

d. Thermal Yield. Measurements of the total thermal energy emitted for air burst weapons of low yield indicate that this energy is proportional to weapon yield and is about one-third of the total yield. From this and figure 3-2 a scaling procedure for maximum radiant power may be derived. Thus $p_{\max} = 4 W^{1/2} \text{KT/sec}$ or $4 \times 10^{12} W^{1/2} \text{cal/sec}$.

Measurements from the ground of the total thermal energy from surface bursts, although not as extensive as those for air bursts, indicate that the thermal yield is a little less than half that from equivalent air bursts. For a surface burst the thermal yield is assumed to be one-seventh of the total yield. For surface bursts, the scaling of the second radiant power maximum (p_{\max}) cannot be determined on the basis of available data. Similarly, there are no data which show what the thermal radiation phenomena may be for detonation altitudes in excess of about 50,000 feet. It is expected that the thermal energy may

increase with altitude of burst, and figure 3-4 gives a purely theoretical estimate of this increase.

3.3 Radiant Exposure vs. Slant Range

a. Spectral Characteristics. At distances of operational interest, the spectral (wavelength) distribution of the incident thermal radiation, integrated with respect to time, resembles very closely the spectral distribution of sunlight. For each, slightly less than one-half of the radiation occurs in the visible region of the spectrum, approximately one-half occurs in the infrared region and a very small fraction (rarely greater than 10 percent) lies in the ultraviolet region of the spectrum. The color temperature of the sun and an air burst are both about $6,000^\circ \text{K}$. A surface burst, as viewed by a ground observer, contains a higher proportion of infrared radiation and a smaller proportion of visible radiation than the air burst, with almost no radiation in the ultraviolet region. The color temperature for a surface burst is about $3,000^\circ \text{K}$. A surface burst viewed from the air may exhibit a spectrum more nearly like an air burst.

b. Atmospheric Transmissivity. The atmospheric transmissivity (\bar{T}) is defined as the fraction of the radiant exposure received at a given distance after passage through the atmosphere, relative to that which would have been received at the same distance if no atmosphere were present. Atmospheric transmissivity depends upon several factors; among these are: water vapor and carbon dioxide absorption of infrared radiation, ozone absorption of ultraviolet radiation, and multiple scattering of all radiation. All of these factors vary with distance and with the composition of the atmosphere. Scattering is produced by the reflection and refraction of light rays by certain atmospheric constituents, such as dust, smoke and fog. Interactions such as scattering which divert the rays from their original paths result in a diffuse, rather than direct, transmission of the radiation. As a result, a receiver which has a large field of view (i. e., most military targets) receives radiation which has been scattered toward it from many angles, as well as the directly transmitted radiation. Since the mechanisms of absorption and scattering are wavelength dependent, the atmospheric transmissivity depends not only upon the atmospheric conditions, but also upon

the spectral distribution of the weapon's radiation. In figures 3-5A and 3-5B the atmospheric transmissivity is plotted as a function of the slant range for air and surface bursts. For each type of burst three sets of atmospheric conditions are assumed. It is believed that these conditions represent the average and the extremes normally encountered in natural atmospheres. These conditions correspond to a visibility of 50 miles and a water vapor concentration of 5 grams/cubic meter; 10 miles visibility and 10 grams/cubic meter water vapor concentration; and 2 miles visibility and 25 grams/cubic meter of water vapor concentration. Curves are presented in appendix I to show under what conditions of ambient temperature and relative humidity the above water vapor concentrations are applicable. The curves of figures 3-5A and 3-5B are plotted to slant ranges equal to one-half the visibility for the three visibility conditions. The reason for this is that the empirical relationships used to obtain the transmissivity values have not been verified for ranges beyond one-half the visibility. As a result, the curves cannot be extrapolated to greater distances with any confidence. If the curves are extended beyond one-half the visibility, there is reason to believe that the values of transmissivity would be too high. Where cloud cover is appreciable or the air contains large quantities of fog or industrial haze, knowledge of the interactions with the radiation is too limited to provide estimates of atmospheric transmissivity.

c. Reflection. If a weapon is burst in the air below a large cloud, the thermal radiation is diffusely reflected downward from the cloud, resulting in greater radiant exposures at a given distance than would be received if no cloud were present. Similarly, if the weapon is burst near the earth's surface, the radiant exposure received at some altitude above the burst (as in the case of an aircraft flying above the detonation) will be greater than that which is received at the same distance on the ground. If the receiver is directly over the burst and the terrain has a high albedo, the reflected radiation from the terrain may be as much as twice the direct radiation. If a reflecting or scattering layer such as a cloud is between the detonation and the target, however, the radi-

ant exposure received will be reduced considerably.

d. Calculation of Radiant Exposure. The radiant exposures at various slant ranges from air and surface burst weapons can be calculated from the following expressions:

$$Q = \frac{3.16 \times 10^6 W (\bar{T})}{D^2} \text{ cal/sq cm (air burst).}$$

and

$$Q = \frac{1.35 \times 10^6 W (\bar{T})}{D^2} \text{ cal/sq cm (surface burst).}$$

where Q = radiant exposure (cal/sq cm)

\bar{T} = atmospheric transmissivity

W = weapon yield (KT)

D = slant range (yds).

The values of \bar{T} for both air and surface bursts are obtained from the appropriate curves in figures 3-5A and 3-5B. Curves showing the radiant exposure (Q) as a function of slant range (D) for three atmospheric conditions for both air and surface bursts are shown in figures 3-6A and 3-6B. These curves are plotted for ranges up to one-half the visibility for the reasons explained in *b* above. The surface burst curves differ from the air burst curves for two reasons—the apparent thermal yield when viewed from the surface for a surface burst is lower than that for an air burst, and the spectral distribution of the surface burst is sufficiently different from that of an air burst to require the use of different atmospheric transmissivity curves. Radiant exposure for a burst in the transition zone may be estimated by interpolation between these curves as explained on the instruction page for figures 3-6A and 3-6B. It should be emphasized that these surface burst curves apply to the radiant exposure of *ground* targets. When the surface burst is viewed from the air, as from aircraft, the apparent radiating temperature and the thermal yield will be greater than when viewed from the ground. All of the curves plotted in figures 3-6A and 3-6B are for a total weapon yield of 1 KT. For weapon yields greater or less than 1 KT these radiant exposures should be multiplied by the yield of the weapon in question.

3.4 Other Influences on Thermal Radiation Propagation

a. Topography and Clouds. Propagation of thermal radiation from a nuclear detonation, like that from the sun, is affected by topography and the atmosphere. At close ranges, where the fireball subtends a relatively large angle, the shadowing effects of intervening objects such as hills or trees are less than are experienced with the sun. As discussed earlier, clouds in the atmosphere significantly affect the propagation of radiation through the atmosphere.

b. Fog and Smoke. Where the burst is in the air above a fog covering the ground, a significant

fraction of the thermal radiation incident on the fog layer is reflected upward. That radiation which penetrates the fog is scattered. These two effects result in substantial reductions in thermal energy incident on ground targets covered by fog. White smoke screens act like fog in the attenuation of thermal radiation. Reductions as large as 90 percent of incident thermal energies are realized by dense fogs or smoke screens.

c. The Wilson Cloud. The Wilson Cloud, which is sometimes formed in a detonation, does not appreciably affect the thermal radiation incident on a target.

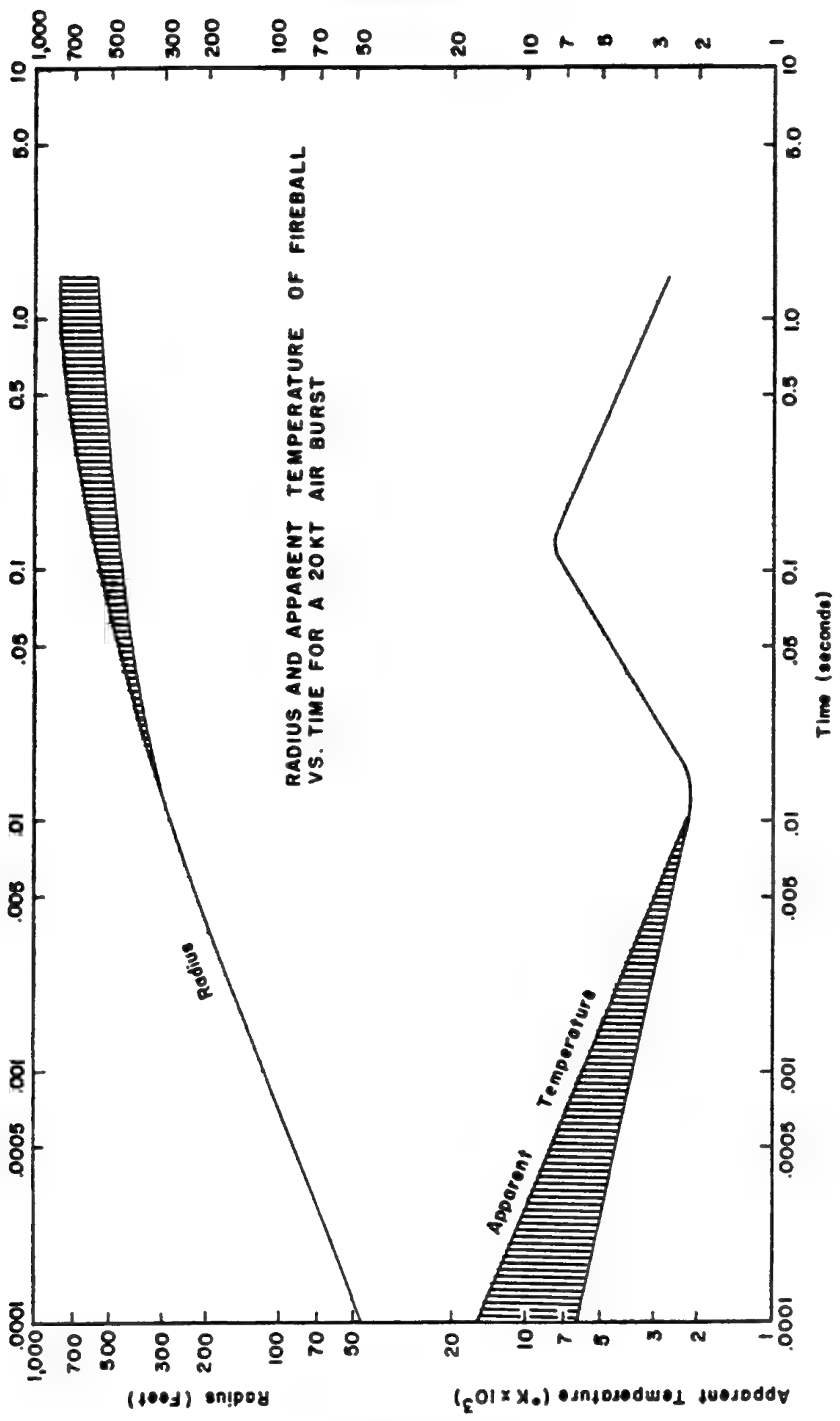

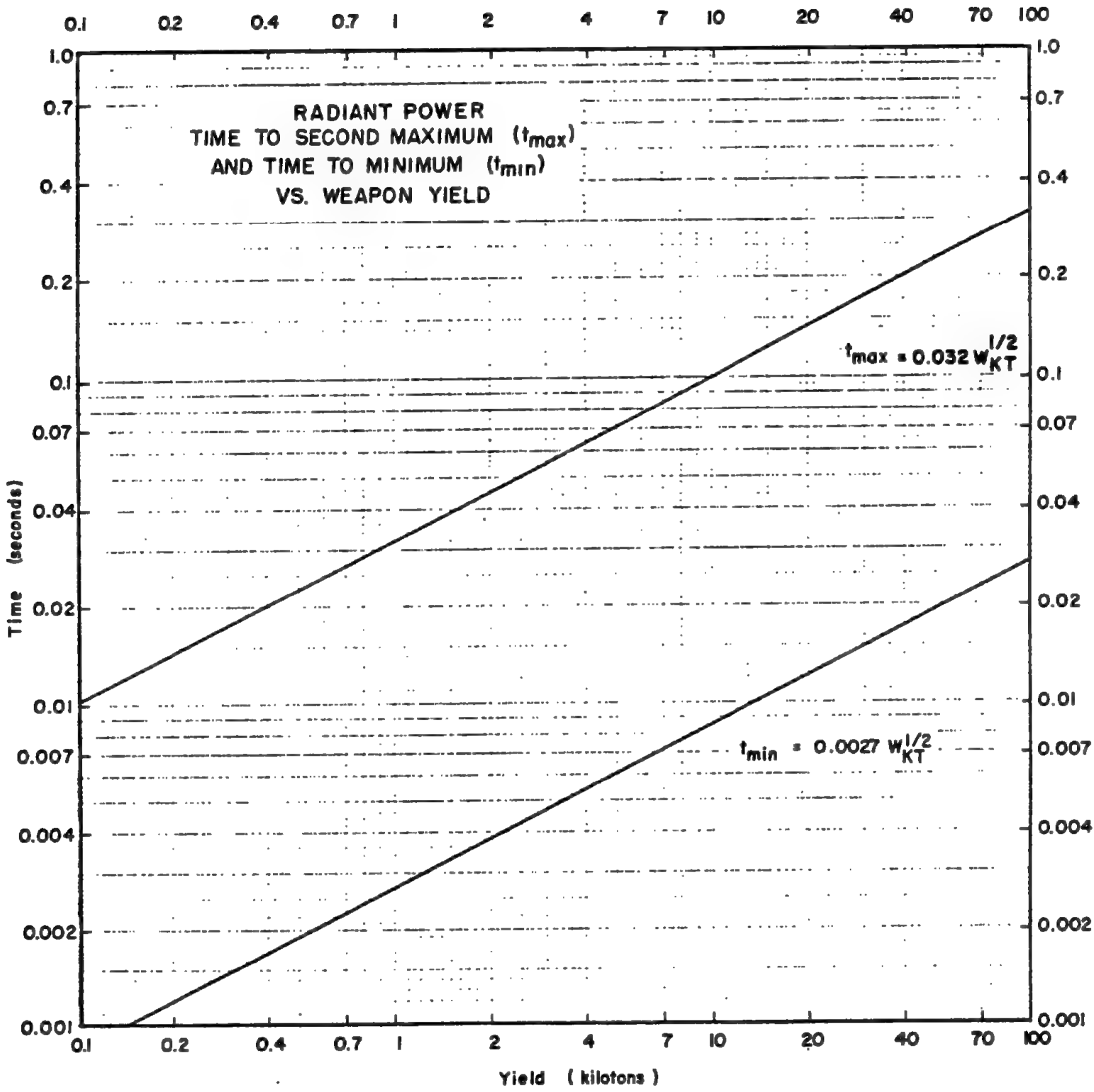

ATMOSPHERIC TRANSMISSIVITY

Figures 3-5A and 3-5B give the atmospheric transmissivity versus slant range for three sets of atmospheric conditions for both air and surface burst weapons. These curves are presented for illustrative purposes, since these were used to derive the radiant exposure vs. slant range curves of figures 3-6A and 3-6B.

The differences between the air burst and surface burst curves are caused by the difference in apparent radiating temperatures (when viewed from the ground) and the difference in geometrical configuration of the two types of burst. The three sets of atmospheric conditions represented are:

- 50 mile visibility and 5 gm/m³ water vapor.
- 10 mile visibility and 10 gm/m³ water vapor.
- 2 mile visibility and 25 gm/m³ water vapor.

It is believed that these conditions pertain to the extreme and the average atmospheres which occur naturally.

Reference can be made to the atmospheric water vapor concentration curves in appendix I to ascertain under what conditions of relative humidity and ambient temperature a particular water vapor concentration will occur.

Reliability. The curves of figures 3-5A and 3-5B have not been verified at ranges beyond one-half the visibility and, as a result, are subject to considerably reduced reliability beyond these ranges.

Related material.

See paragraph 3.3b.

See also figures 3-6A and 3-6B.

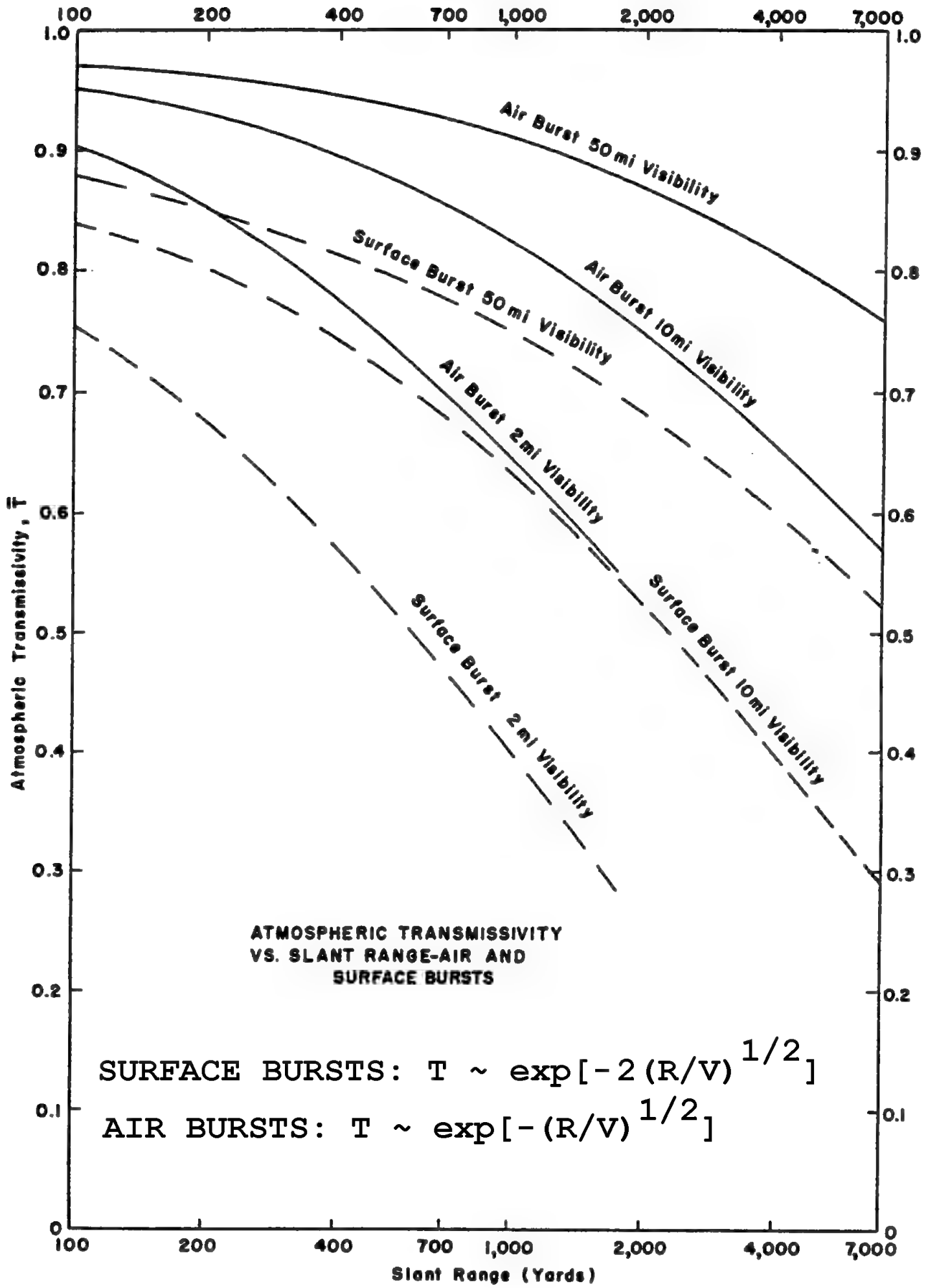

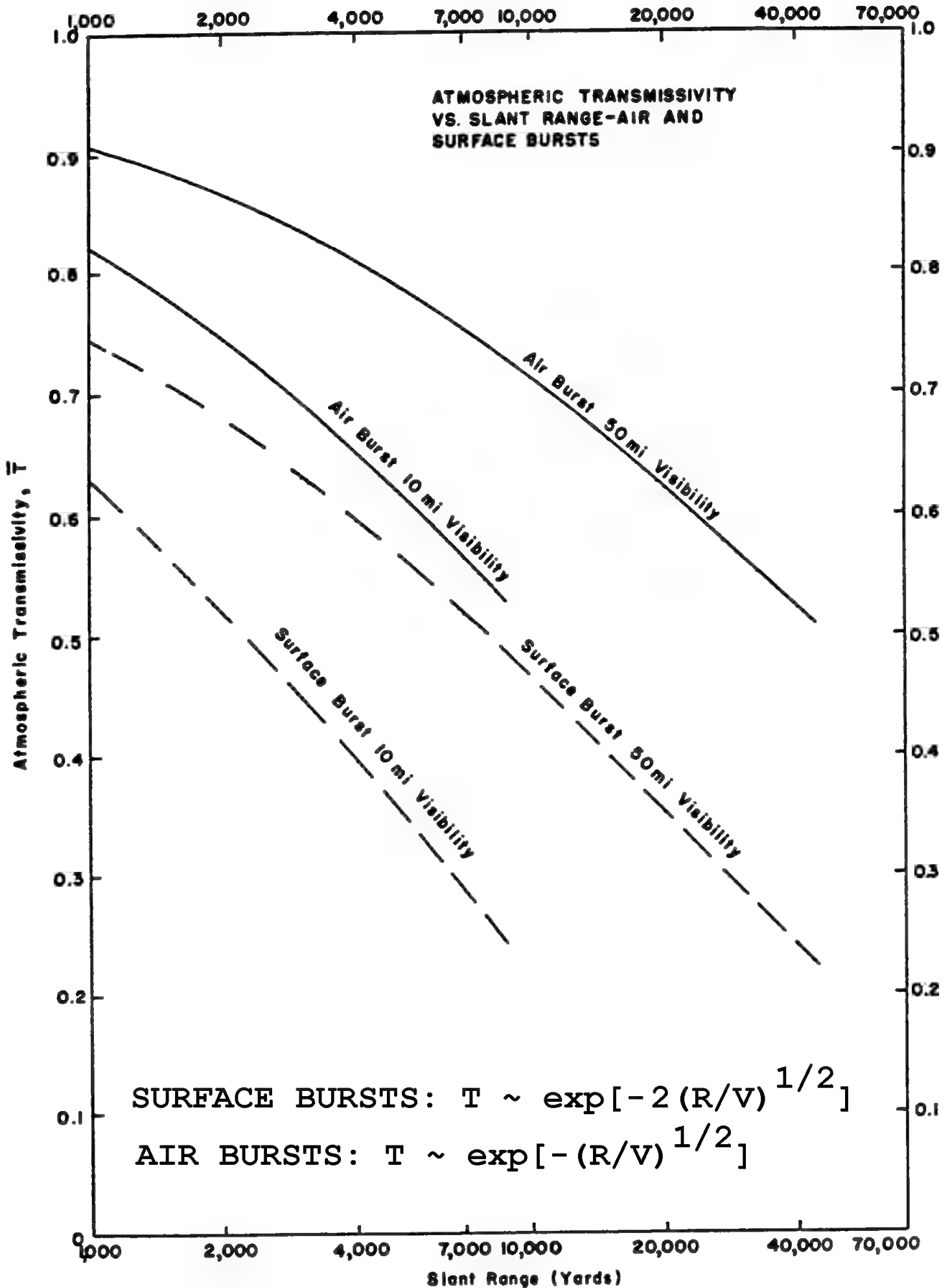

INITIAL GAMMA RADIATION DOSE VS SLANT RANGE
SURFACE BURST AND SURFACE TARGET

RELATIVE AIR DENSITY, 1.0

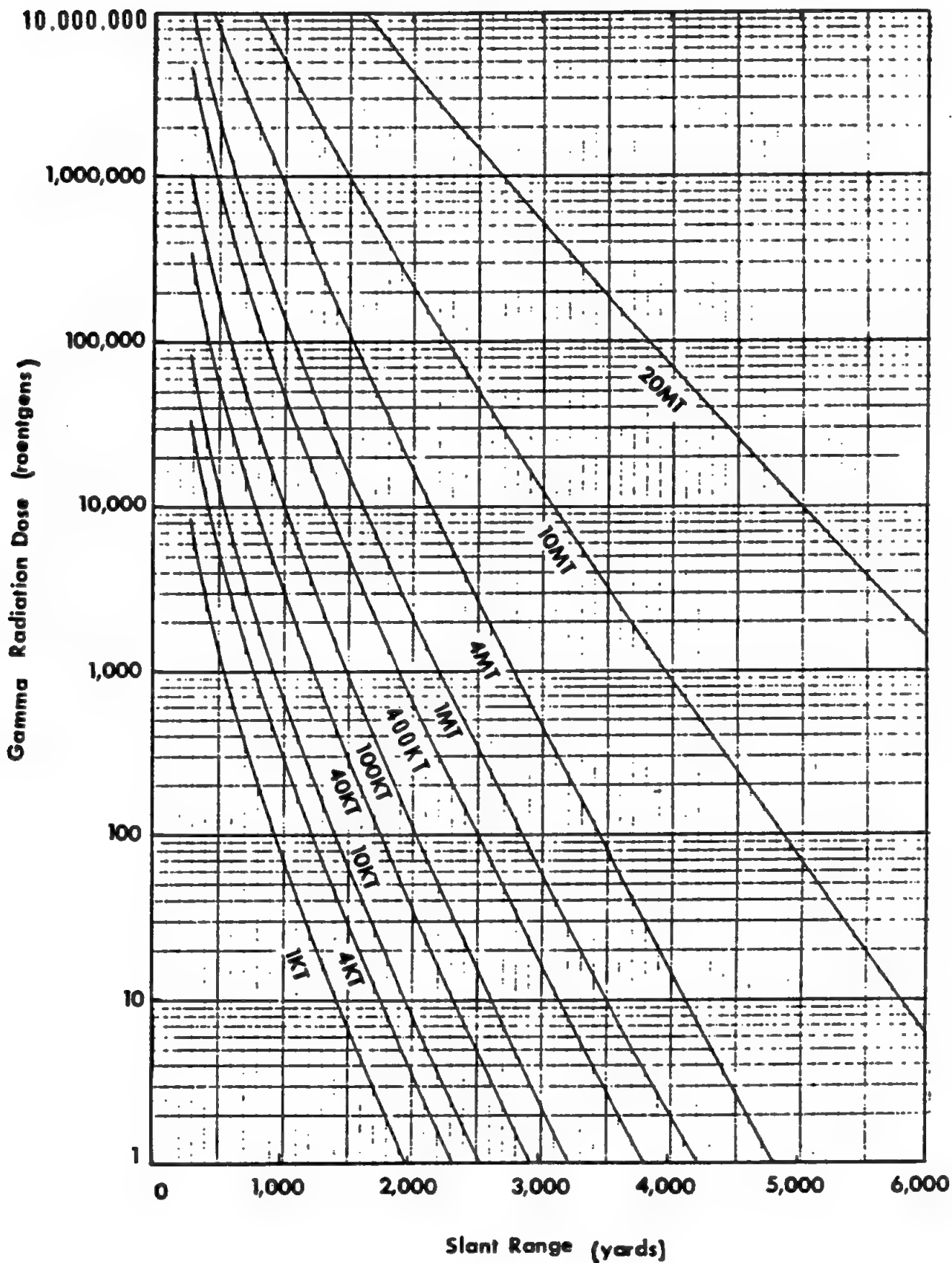

Note: Applicable to other situations as indicated on facing page.

INITIAL GAMMA RADIATION DOSE V.S. SLANT RANGE
SURFACE BURST AND SURFACE TARGET
RELATIVE AIR DENSITY, 0.9

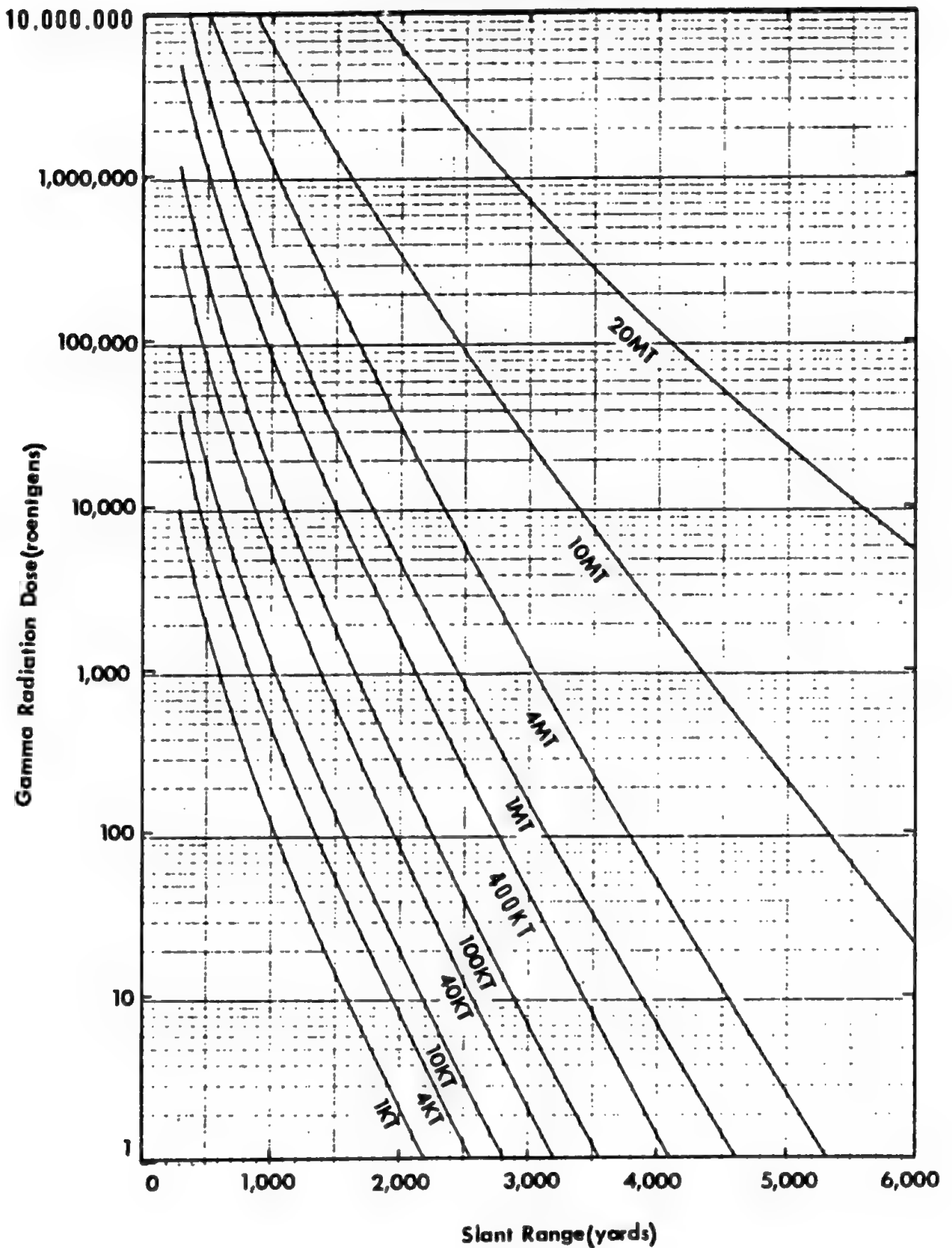

Note: Applicable to other situations as indicated on facing page.

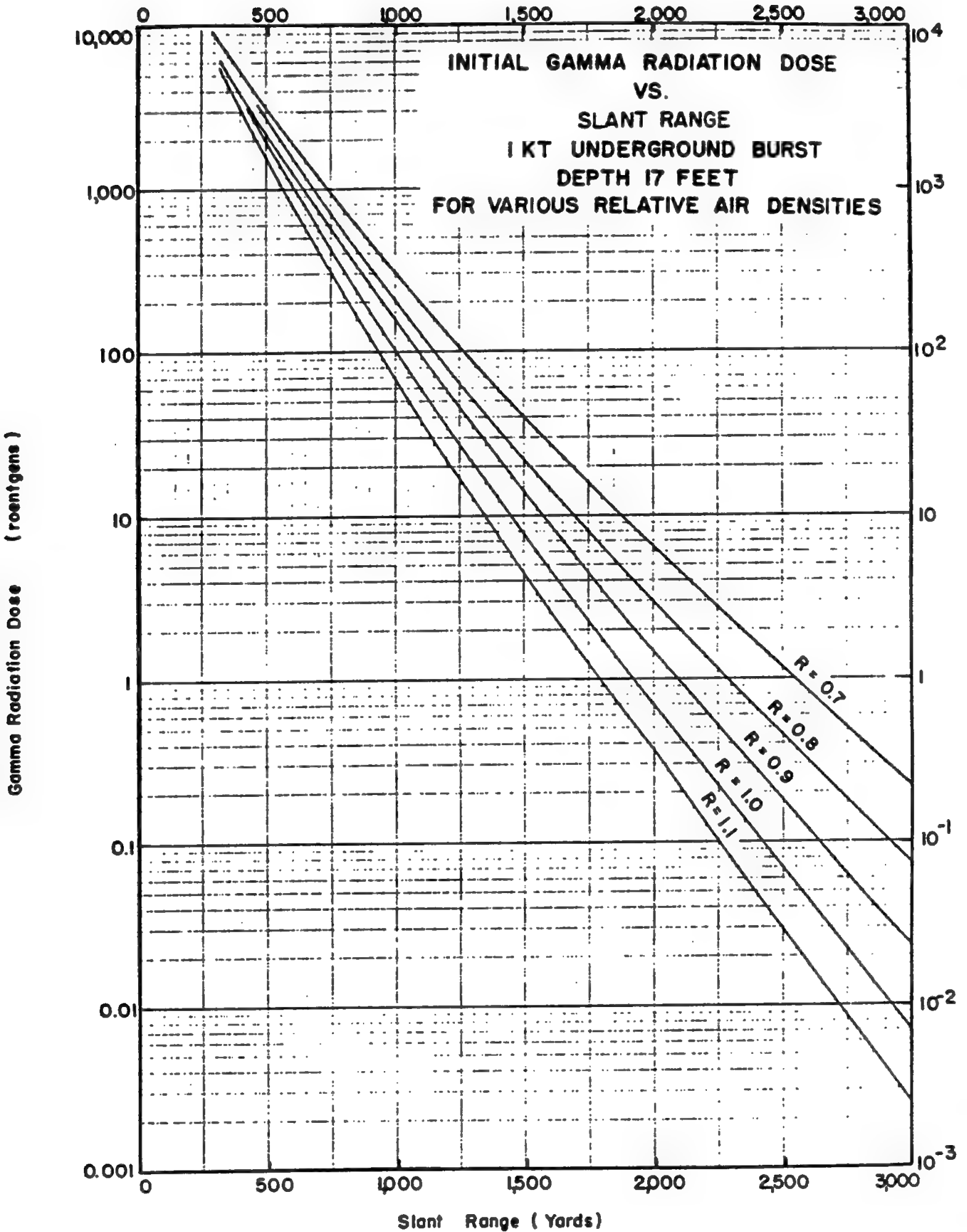

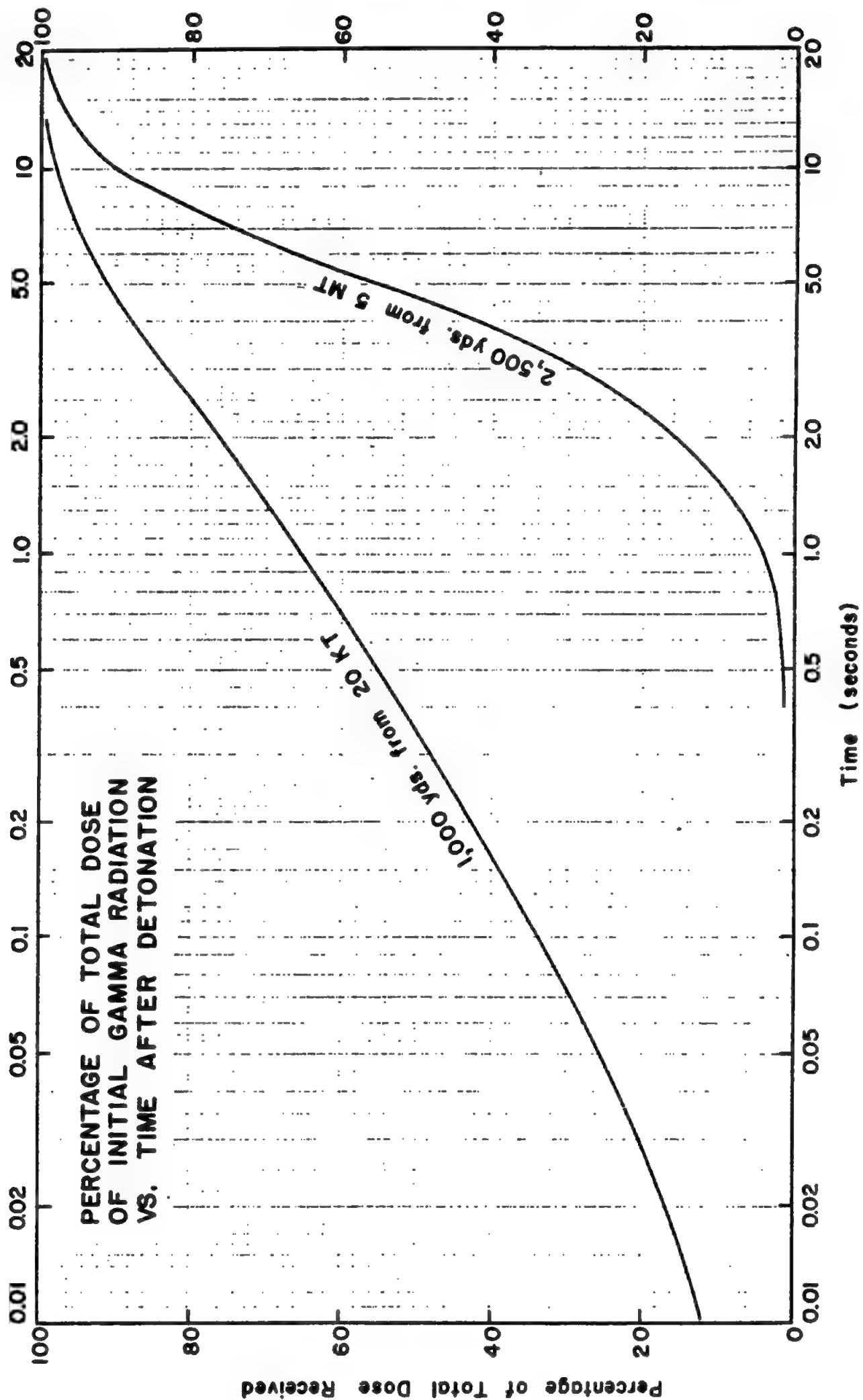

PERCENTAGE OF TOTAL DOSE
OF INITIAL GAMMA RADIATION
VS. TIME AFTER DETONATION

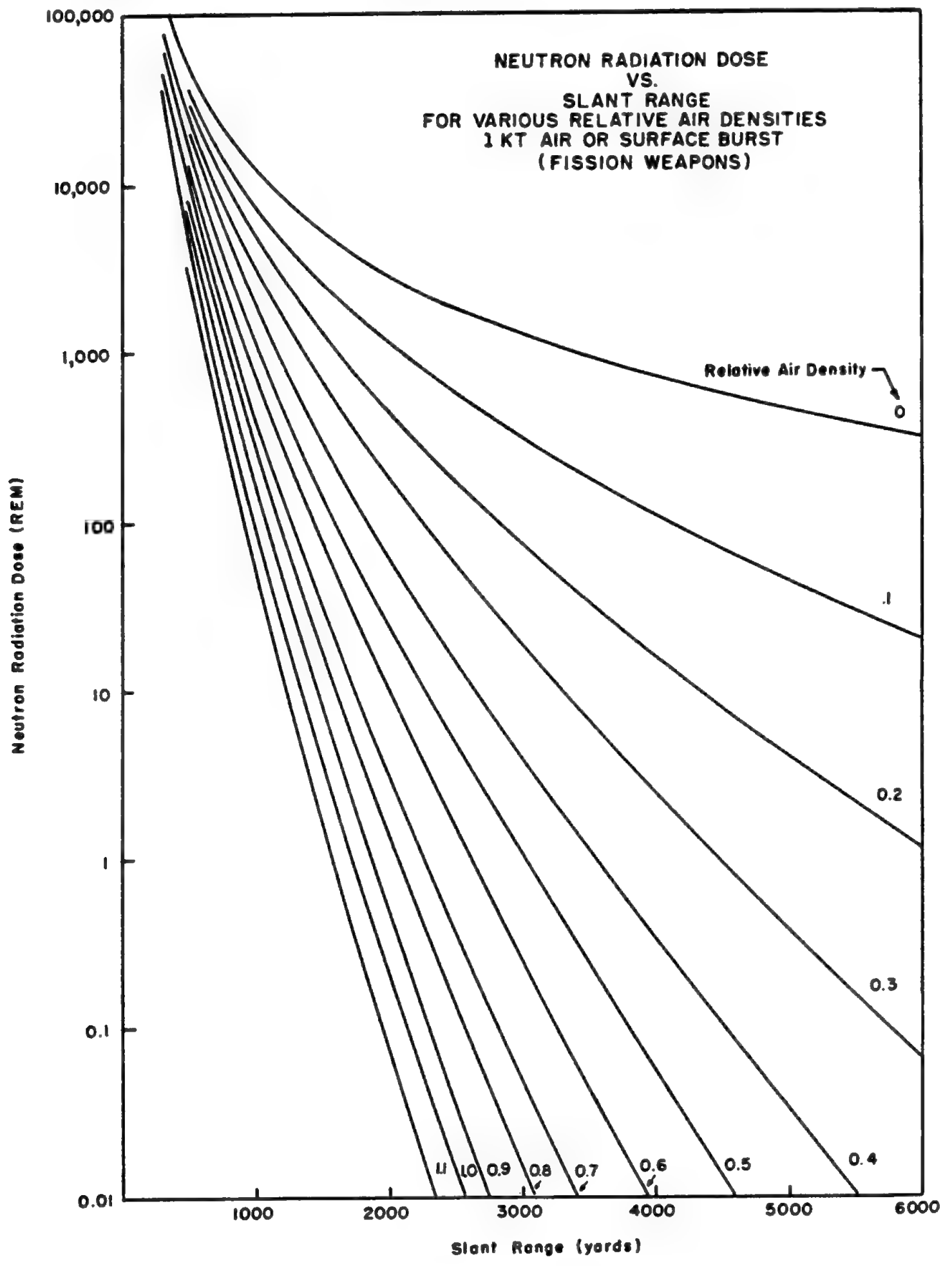

NEUTRON RADIATION DOSE VS. SLANT RANGE
FOR VARIOUS RELATIVE AIR DENSITIES
1 MT AIR OR SURFACE BURST (FUSION WEAPONS)

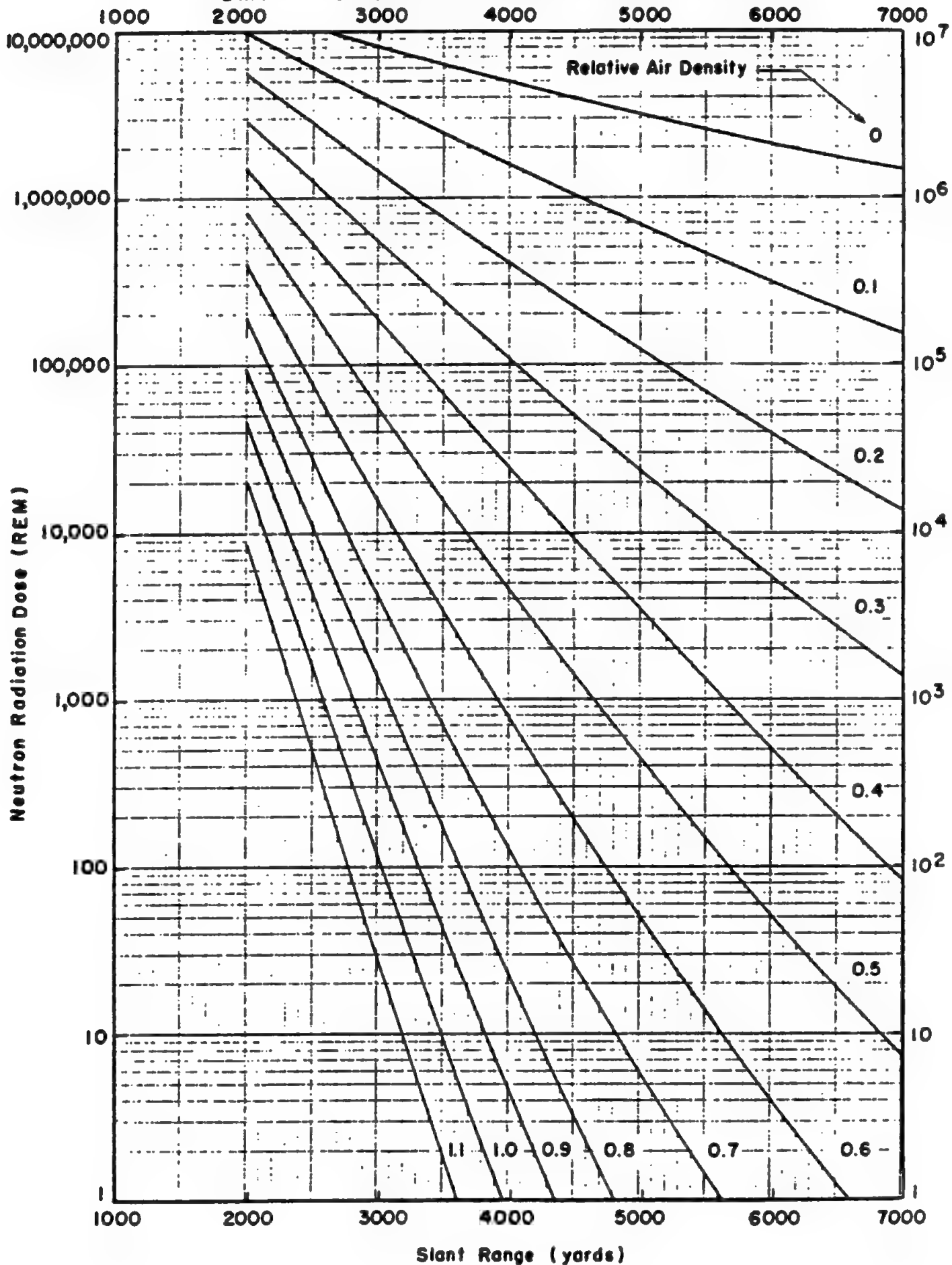

4.3 Residual Radiation

a. General. Most of the damage caused by a nuclear explosion occurs within a few seconds after the detonation; however, there can be a further radiological hazard to personnel, extending over long periods of time. This hazard is most intense when the weapon is detonated at such an altitude that surface particles are drawn into the fireball. The resulting heat transfer changes the physical characteristics of the particles, causing them to become efficient scavengers of the finely divided radioactive remains of the weapon. These radioactive particles then fall under the action of gravity and are spread over a region which is determined by factors such as particle size, cloud height, and wind pattern. The dangerous area covered by this fallout can be of the order of thousands of square miles.

If the altitude of detonation is high enough, the above described interactions with the ground do not occur. The bomb materials will then remain suspended in the atmosphere for very long periods of time and, generally speaking, will settle out in low concentration over much of the earth's surface. This long range settling presents no significant military hazard.

For yields less than 100 KT, the height of burst at which fallout ceases to be a significant military hazard is about $100 W^{1/3}$ feet. For yields in excess of 100 KT the height of burst at which fallout ceases to be a military hazard is not well defined; however, in the absence of data, the height of burst may be conservatively taken to be $180 W^{0.4}$ feet.

b. Air Burst. The surface contamination effects of fallout from an air burst weapon are militarily insignificant in most cases, since the bomb cloud carries practically all the radioactive bomb debris to high altitudes. In general, by the time this material can fall back to earth, dilution and radioactive decay will decrease the activity to levels which are no longer important. An exception may occur in the case of a small yield weapon burst in the rain. In this case, the scavenging effect of the precipitation may cause a rain-out of radioactive material which will provide a hazard to personnel located downwind and downhill, and outside the hazard area of initial radiation and other effects. Although the range of weapon yields for which rain-out may become

hazardous is not large, quantitative treatment of the problem is difficult. The contamination pattern on the ground depends upon two major dynamic processes, each of which is extremely sensitive to several factors. The major processes are—

- (1) The scavenging effect of precipitation on suspended fission products in the atmosphere, and
- (2) The flow and ground absorption of rain water after reaching the ground.

Some of the factors which influence the scavenging effect are—

- (1) Height and extent of the rain cloud.
- (2) Raindrop size and distribution.
- (3) Rate of rainfall.
- (4) Duration of precipitation.
- (5) Position of the nuclear cloud relative to the precipitation.
- (6) Hygroscopic character of the fission products.
- (7) Solubility of the fission products.
- (8) Size of the fission fragments.

The flow and ground absorption of the rain water will, in turn, depend upon such factors as—

- (1) Soil porosity.
- (2) Drainage features, including rate of drainage.
- (3) Degree of soil saturation.

Even in extreme cases, the rainout from an air burst should not be a serious military problem for yields in excess of 20 KT, and for the average case, it should not be a serious problem for yields in excess of 8 KT. Although the weapons of greater yield produce more radioactive material, the updrafts carry the bulk of the material up through the weather to an altitude above the level of precipitation.

Thus, under some circumstances, a rain-out problem may exist; however, it must be evaluated with respect to local conditions. Ditches, puddles and low ground where water collects should be avoided unless survey indicates these areas are safe. Caution should be exercised for a considerable distance downwind and downhill from the burst. So long as drainage is taking place, the rate of decrease in intensity is likely to be greater than decay laws predict.

In addition to rain-out, another contamination mechanism assumes some importance in the case

GENERALIZED LOCAL CONTOURS FOR RESIDUAL RADIATION

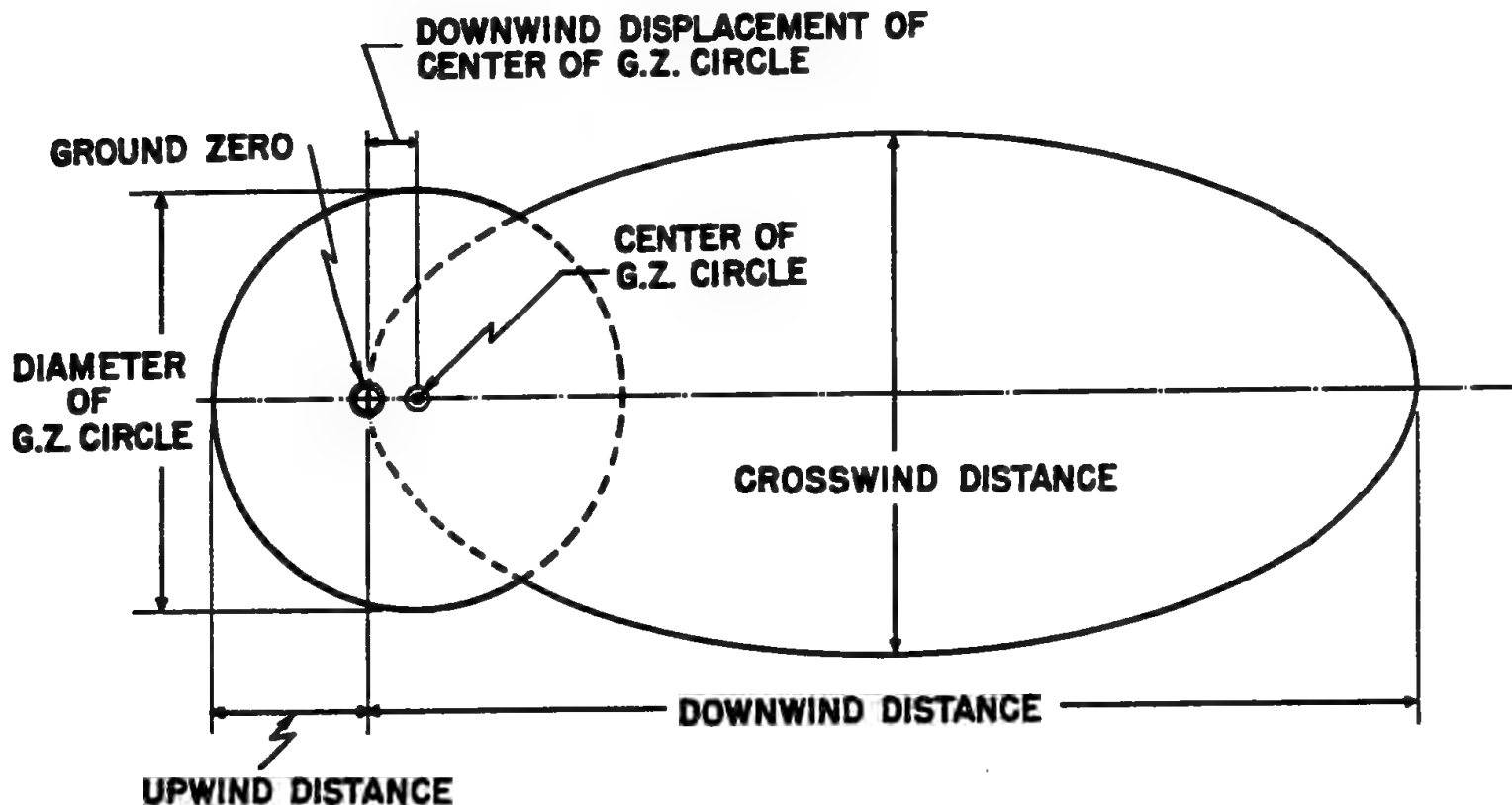

detonation, with a corresponding reduction in the areas of the lower dose rate contours farther out.

- (c) *Idealized contours.* In any discussion of the areas affected by residual contamination from fallout, it is convenient to set up a system of contamination dose rate contours which, although simplified and idealized, fit actual contours measured in the field as closely as possible. Figure 4-12 illustrates such a contour system. The "idealized" contour shown consists necessarily of two parts—the ground zero circle, and an elliptical approximation to the downwind component of the fallout. The ground zero circle is formed quite soon after the detonation, largely from heavy particulate matter, throw-out, and soil made active by neutron capture reactions. The parameters which define it are its diameter and the downwind displacement of its center from ground zero. The idealized downwind component, consisting of the

fallout proper, is elliptical in shape, and the parameters which define it are its major and minor axes (the downwind and crosswind extent respectively). One end of the ellipse is at ground zero. To define the downwind axis, a simplifying assumption is made—that the downwind direction and extent are determined by a single wind of constant velocity, the so-called "scaling wind." To obtain the scaling wind it is first necessary to obtain the "resultant wind vector" for each of an arbitrary number of equally spaced altitude zones between the top and bottom of the stabilized cloud. Each resultant wind vector is the vector average of all wind vectors for equally spaced altitude intervals from the altitude zone in question down to the surface. The scaling wind is then the vector average of all the resultant wind vectors for the various altitude zones within the cloud. As a rule wide discrepancy from the idealized ellip-

e. *Subsurface Burst.*

(1) *Underground burst.* A large amount of residual contamination is deposited in the immediate vicinity of the burst point after an underground detonation, because the major portion of the radioactive material falls quickly from the column and cloud to the surface. A very shallow underground burst conforms rather closely to the contamination mechanisms and patterns outlined previously for land surface bursts. As depth of burst is increased, however, a greater percentage of the total available contaminant is deposited as local fallout, until for the case of no surface venting, all of the contamination is contained in the volume of ruptured earth surrounding the point of detonation.

Families of curves are given in figures 4-20 through 4-23 by means of which idealized dose rate contours for a reference time of 1 hour after detonation can be drawn for underground bursts of weapons with yields between 1 KT and 1 MT at a depth of $17 W^{1/3}$ feet with a 15 knot scaling wind. Multiplying factors are given in figure 4-24 by means of which contour parameters can be estimated for depths other than $17 W^{1/3}$ feet, down to a limiting depth of $70 W^{1/3}$ feet. As the depth of burst becomes greater, the contour shapes depart from the idealized pattern, and, particularly in the case of the higher dose rate contours, tend to become more nearly circular. For this reason, the areas obtained by use of the scaling factors from figure 4-24 for burst depths greater than $17 W^{1/3}$ feet will more nearly represent the actual pattern than will the downwind and crosswind distances for the higher dose rate contours. A more precise scaling is not warranted on the basis of present understanding of the phenomena. For depths of burst greater than $70 W^{1/3}$ feet, virtually all of the available contamination comes down in the vicinity of the burst point; as burst depth is increased, contours can be expected to decrease in size,

with increase in dose rate values in and near the crater. Contours may be drawn for other wind values in the same manner as described for land surface bursts. The contour values given are for an unshielded, open area with substantially level terrain.

(2) *Underwater burst.*

(a) *General.* One test at mid-depth in shallow water provided some information on the residual radiation from an underwater detonation. The rather specialized burst conditions make application of the results to specific cases of interest of doubtful validity; however, certain guidelines were established which are applicable and useful in the general case. It was shown that for a ship subjected to fallout radiation, much of the contaminated fallout material drains off the ship into the water, and rapidly becomes relatively ineffective because of the dilution due to mixing in water. For adjacent land areas, residual radiation dose rates about four times as great as on board ship at the same relative position are expected soon after completion of fallout, because dilution and run-off do not occur. For adjacent land areas, the decrease in dose rate with time can be calculated from figure 4-13; however, this cannot be done for ships. As in the case of other types of contaminating bursts, the area of contamination varies considerably with meteorological conditions, particularly with wind.

(b) *Harbor burst.* In the case of a nuclear explosion in a comparatively shallow harbor, as in the hold of a ship, more than half of the available radioactivity associated with the device is deposited as local fallout, and large localized high dose rate contours are expected on the adjacent land masses. Although it does not appear feasible to attempt a detailed delineation of contour shapes for a harbor burst on the basis of information available, magni-

tudes of contour areas expected can be given with some confidence. Figure 4-25 indicates expected harbor burst contour areas on adjacent land masses for yields from 1 KT to 1 MT. For yields in the megaton range, contour areas should be estimated from the surface burst curves already presented (fig. 4-14B). To estimate dose rates on the weather decks of anchored ships in a harbor, divide the land-mass values given by four; and for ships alongside a wharf, divide the land-mass values by two.

f. Ground Zero Dose Rates. The residual dose rate curves presented herein make no provision for contours delineating dose rates greater than 3,000 roentgens per hour, except in the case of harbor bursts. Such dose rates occur in "hot spots" rather than over significant areas. The maximum residual radiation dose rates observed on the ground in such hot spots at a reference time of $H+1$ hour, regardless of weapon yield, have been more than 3,000 r/hr and less than 10,000 r/hr for surface burst nuclear weapons. The burst conditions for most of these shots were not truly representative of land shots; hence, there is a large degree of uncertainty regarding the maximum dose rates which may be expected at ground zero under true land surface burst conditions. Higher dose rates may be expected only under certain special circumstances, such as deep underground bursts and bursts in shallow harbors, and are not normally expected for land surface bursts.

g. Total Dose Received. To estimate the dose actually received at a point within an area con-

taminated by fallout, estimate the time of arrival of fallout at that point (using the scaling wind velocity and the distance from the burst point) and integrate the curve of dose rate as a function of time over the period the individual is within the area. The same procedure is used for the case of a person entering a contaminated area at some time after completion of fallout. Figure 4-26 is presented to facilitate this computation, and can be used to estimate total radiation dose received while in a contaminated area. If, at the time of the explosion, the individual is within the radius of effect of the initial radiation, the acute dose so received must be added to the cumulative residual radiation dose in the manner outlined in paragraph 6.3b to obtain the total dose received. If the individual is sheltered, the free field value so obtained should be multiplied by a reduction factor estimated from the degree of shielding involved, as described in paragraph 6.5.

h. Dose Contours. Approximate total dose contours for accumulated doses received during the 48 hours immediately following burst time can be estimated using the appropriate 1-hour dose rate contour curves in conjunction with a scaling factor obtained from figure 4-27. The scaling factor averages the time of arrival effect for 500 roentgen total dose contours using a 15 knot scaling wind, and gives results sufficiently accurate for planning purposes over a range of doses from 100 r to 1,000 r. This method may be used with somewhat less accuracy for accumulated doses outside this range. It should be recognized that dose and dose rate contours do not have the same shape, although the shapes are sufficiently alike to make this approximate method useful.

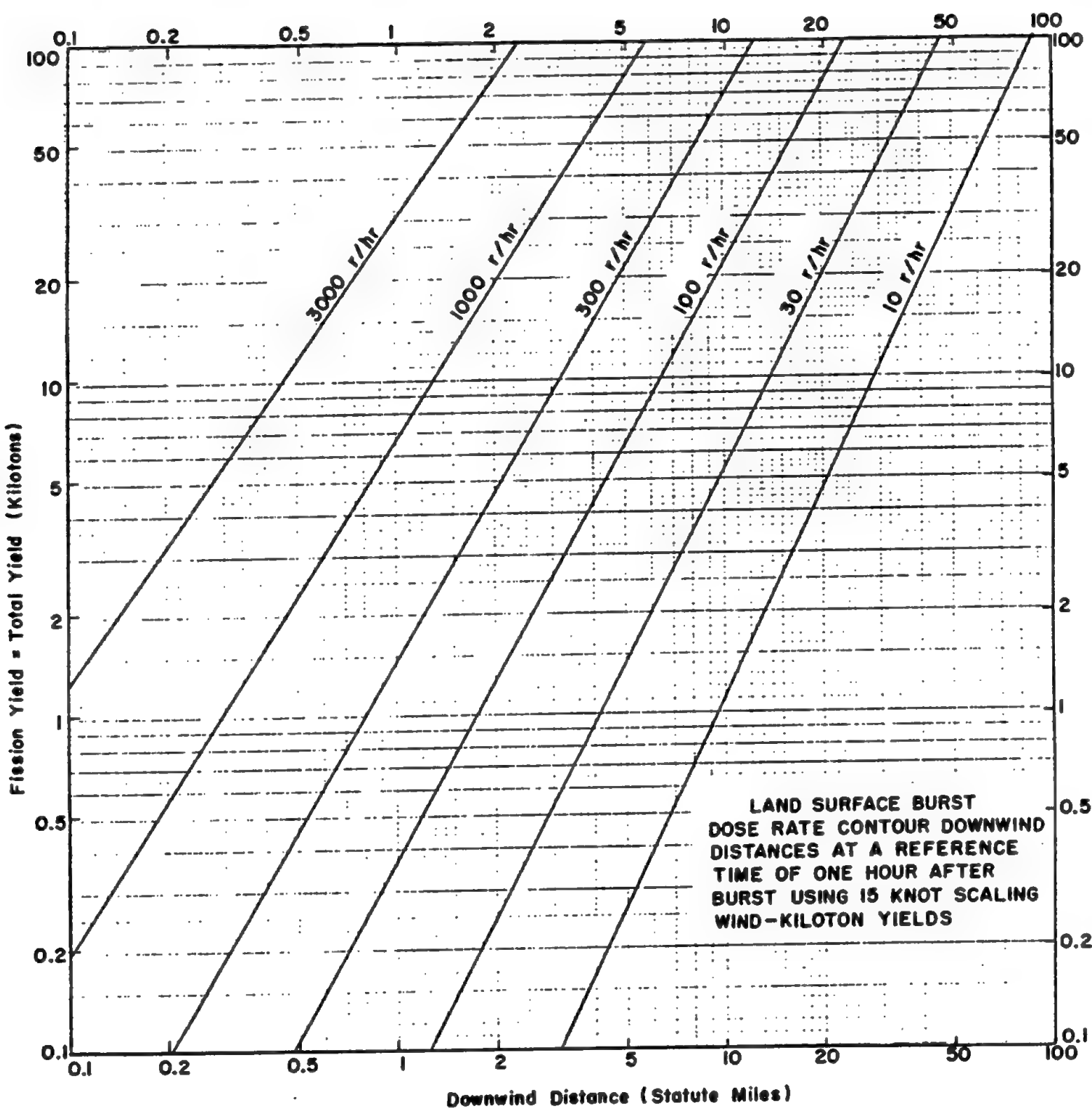

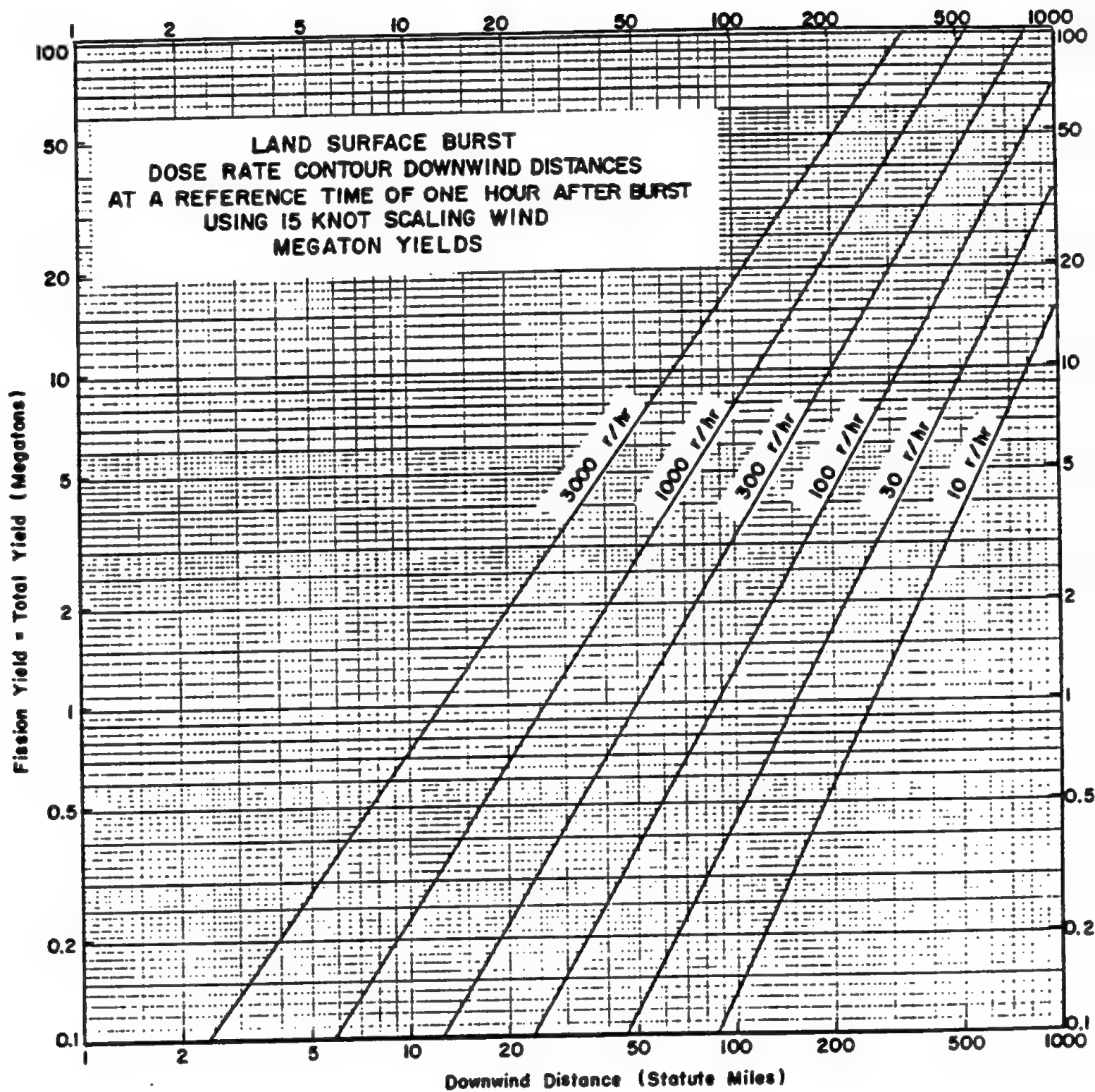

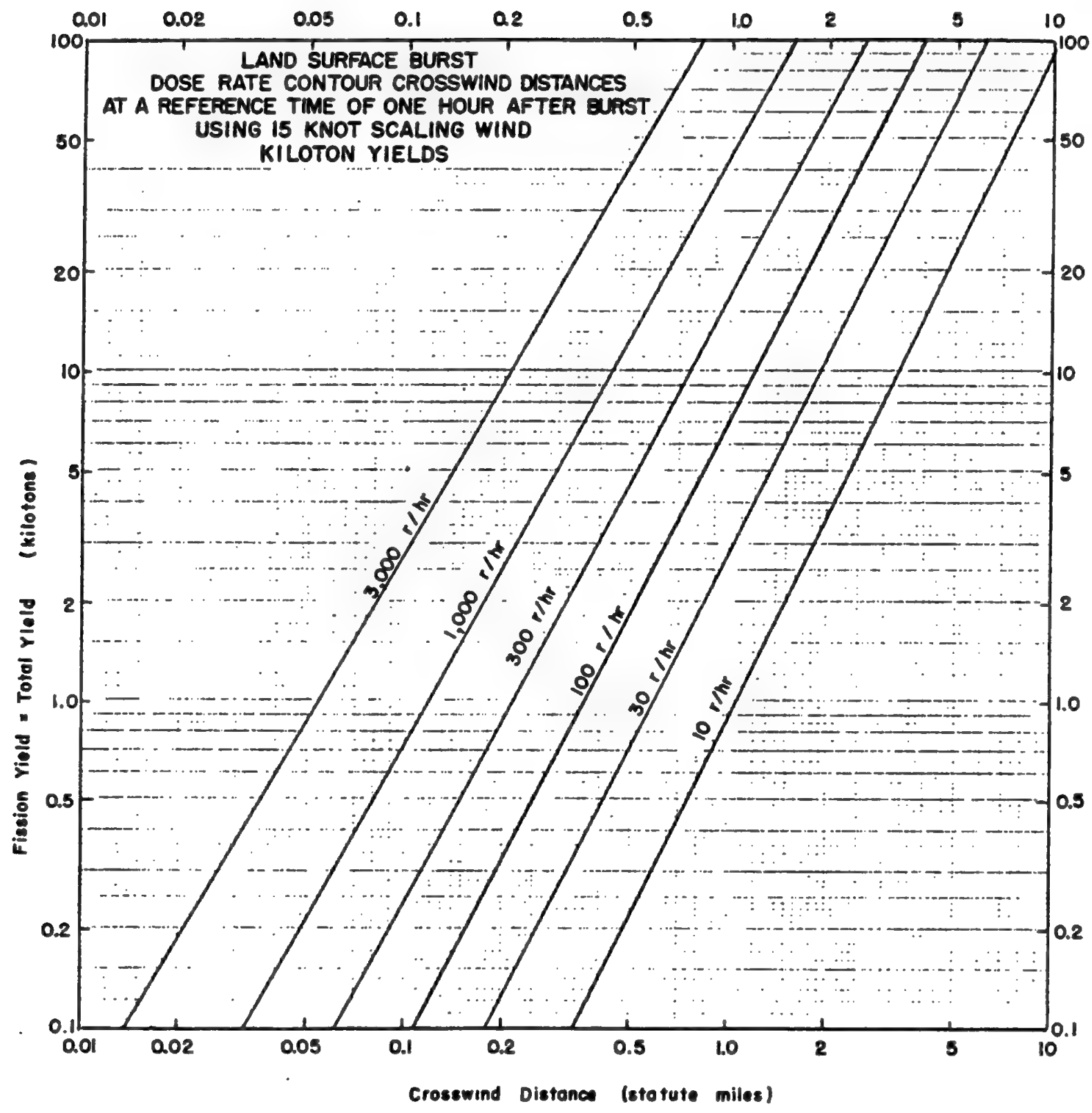

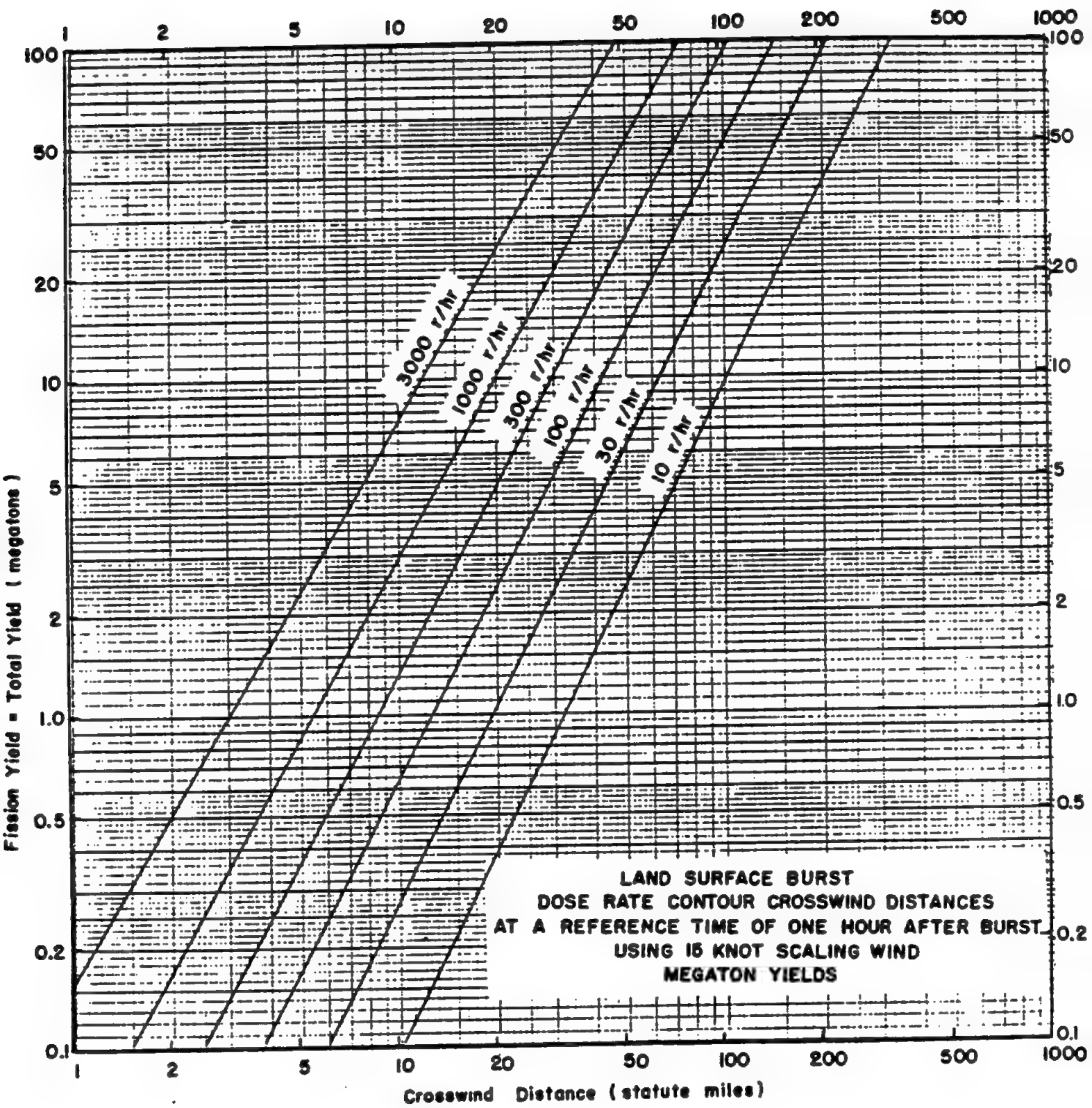

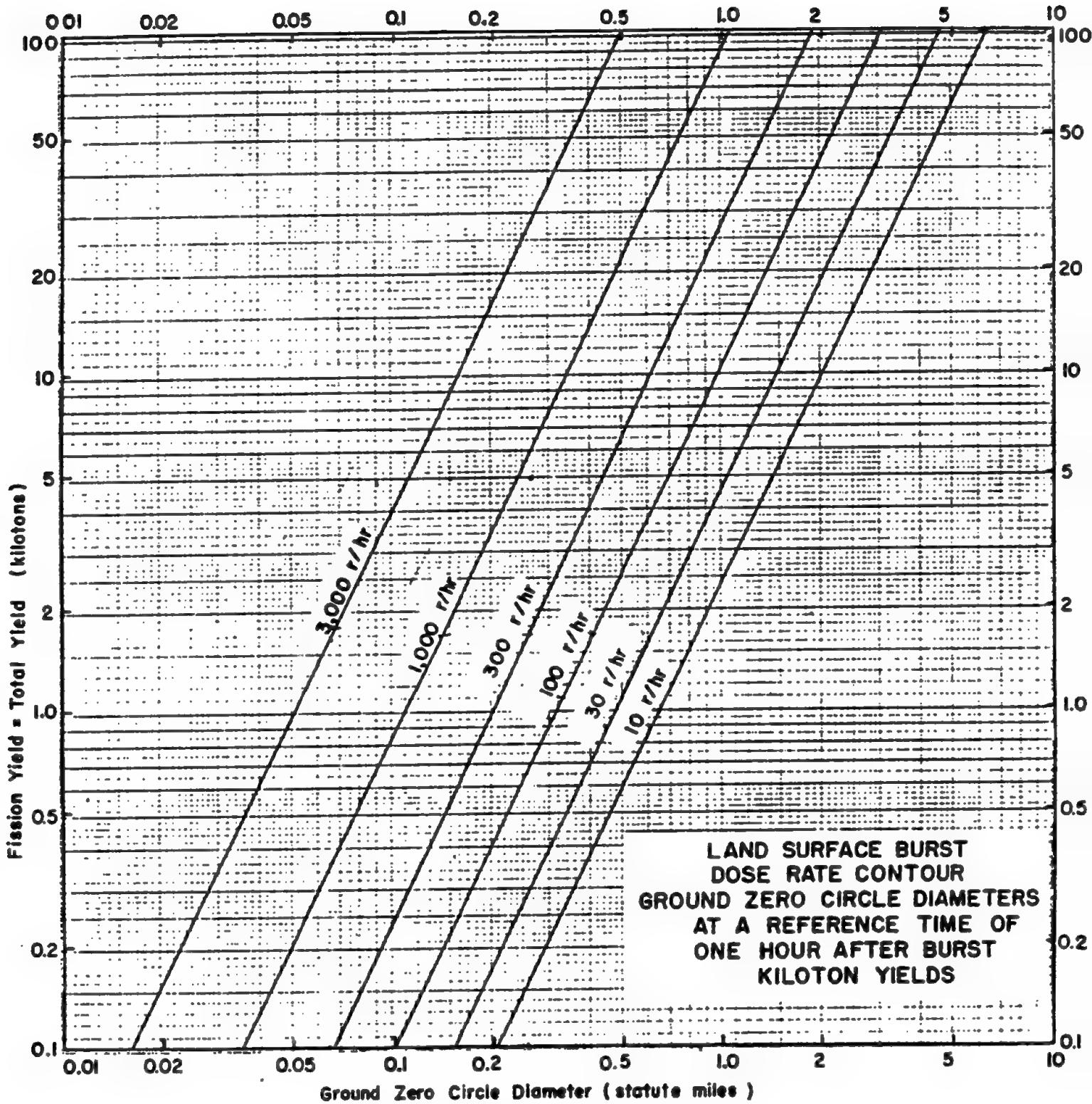

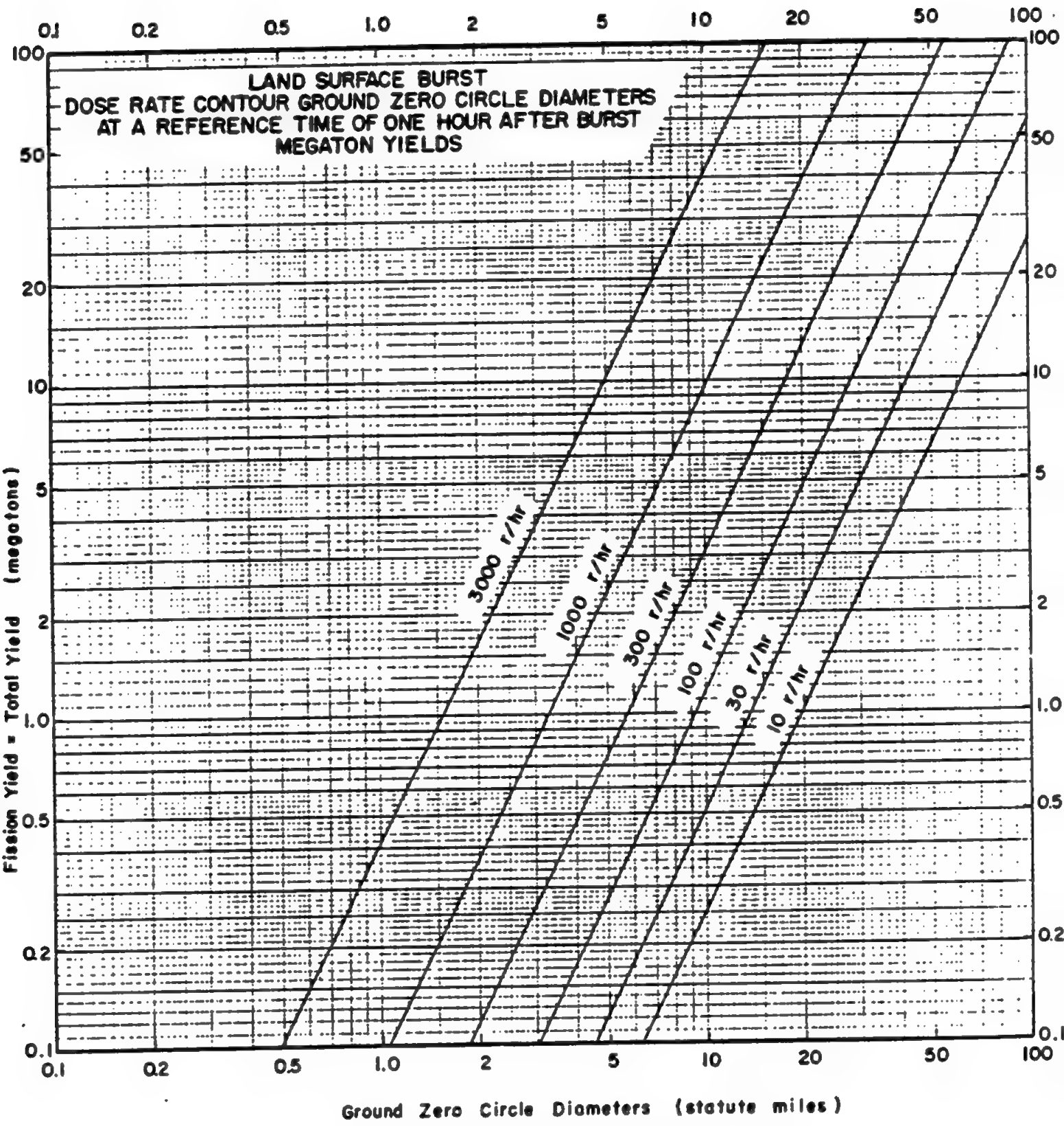

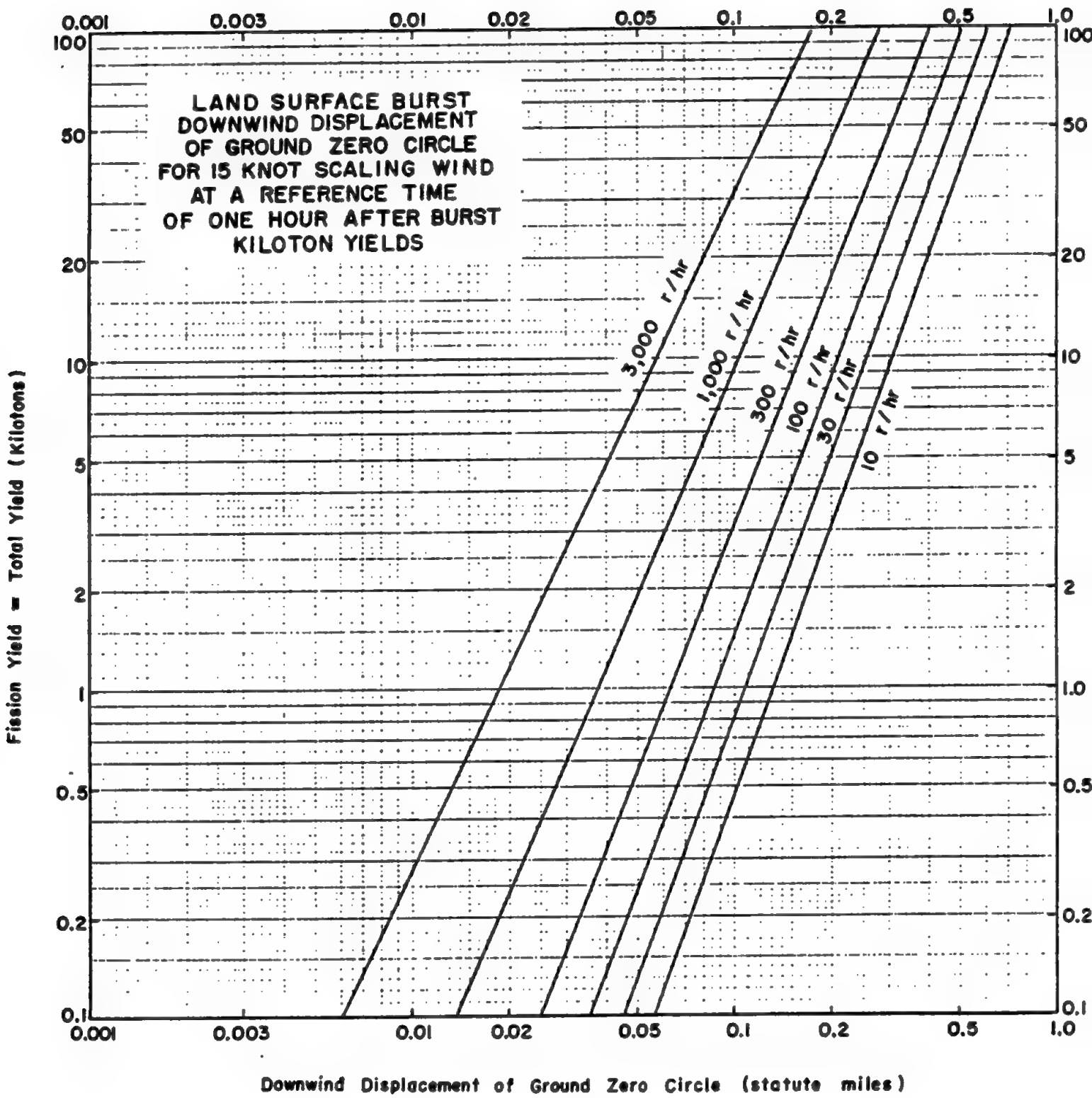

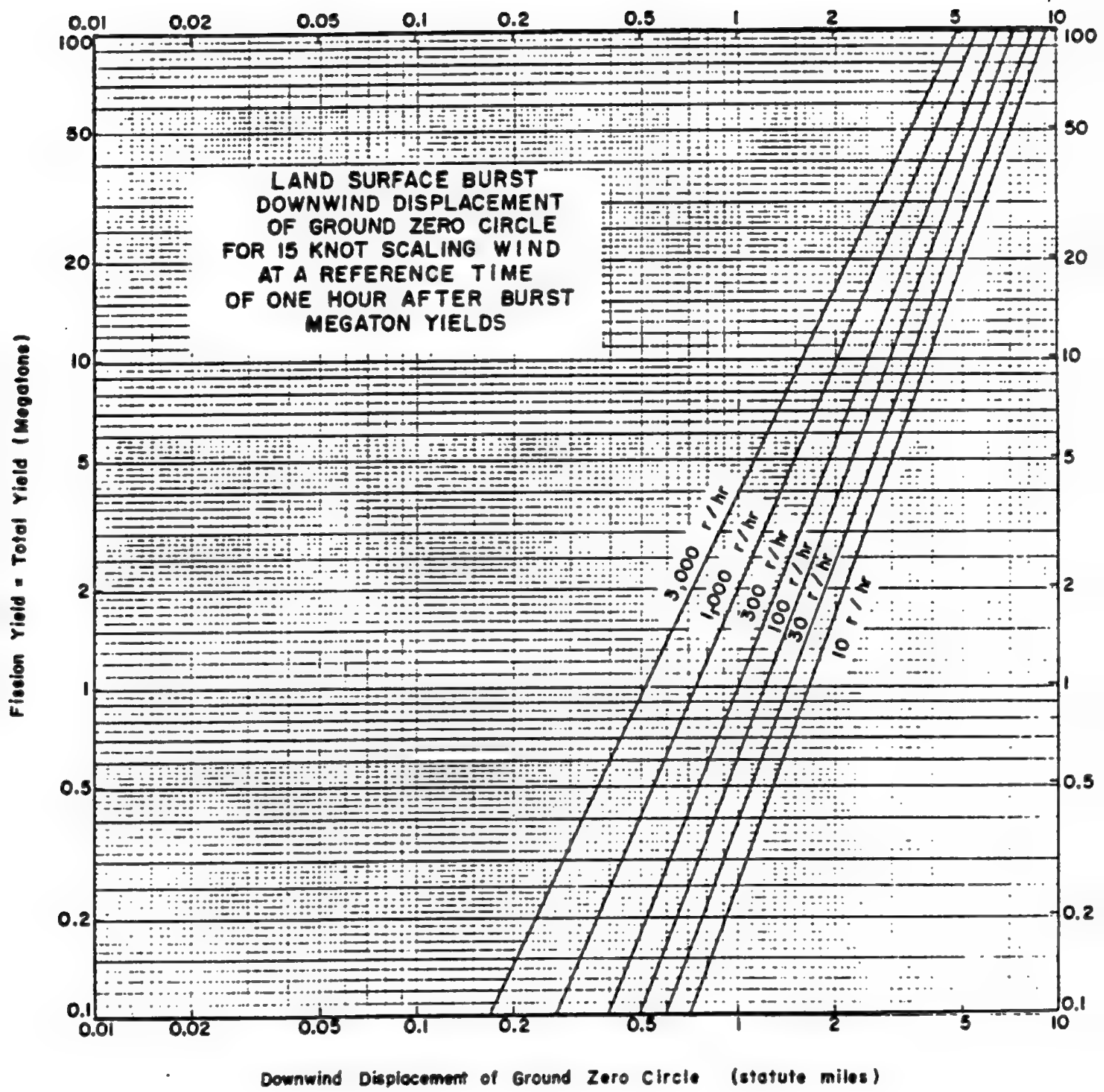

HEIGHT OF BURST ADJUSTMENT FACTOR FOR DOSE RATE CONTOUR VALUES

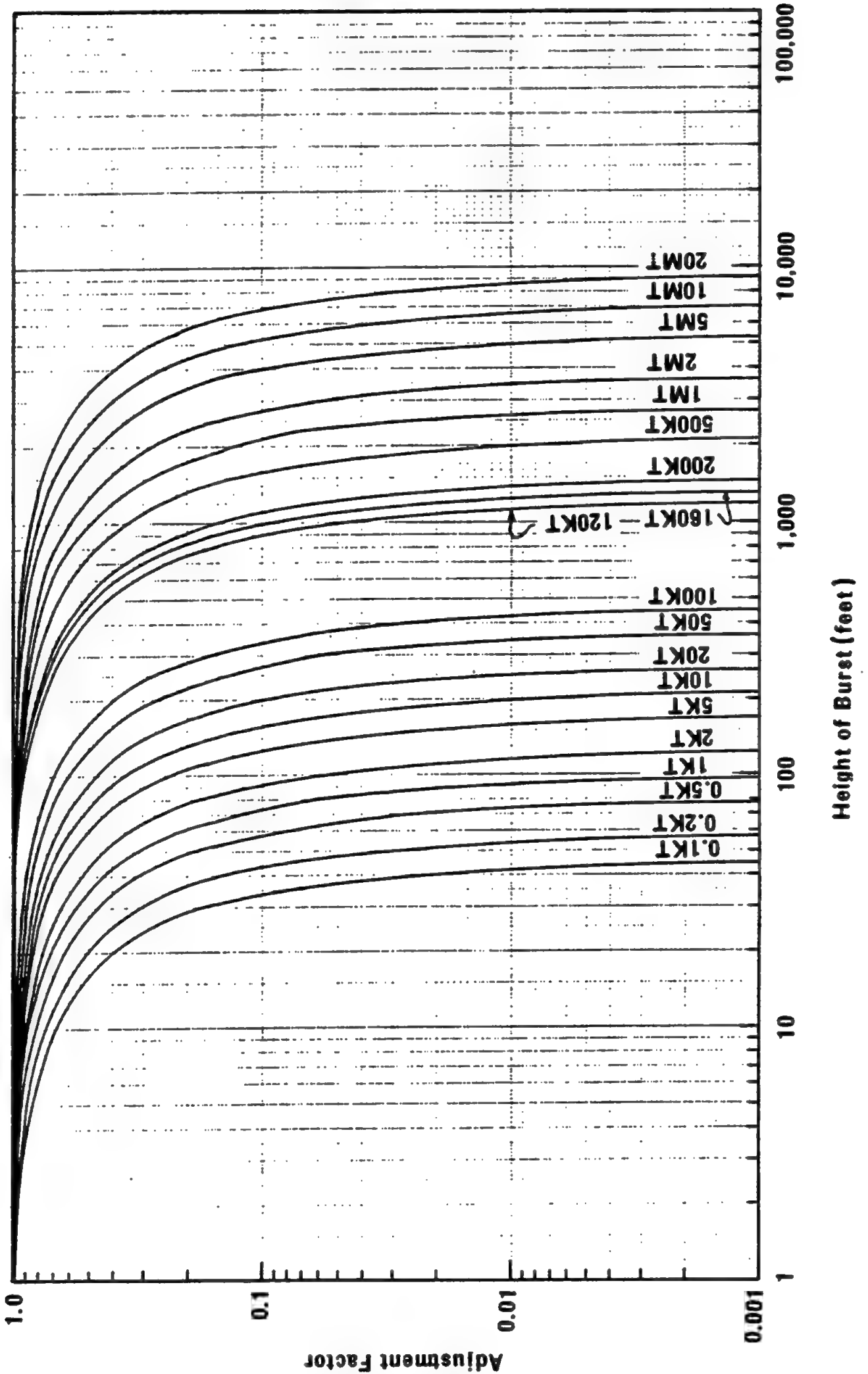

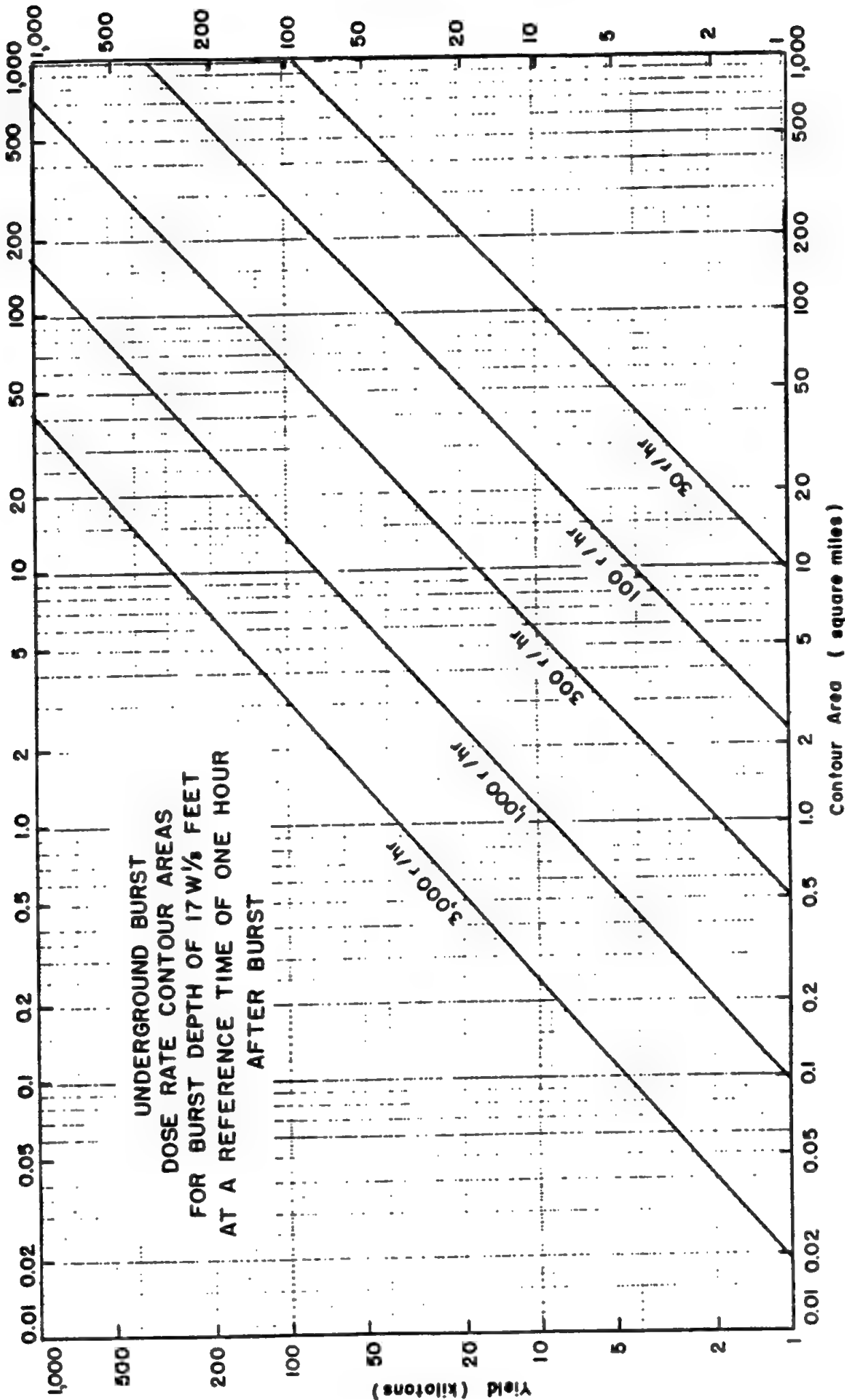

~~CONFIDENTIAL~~

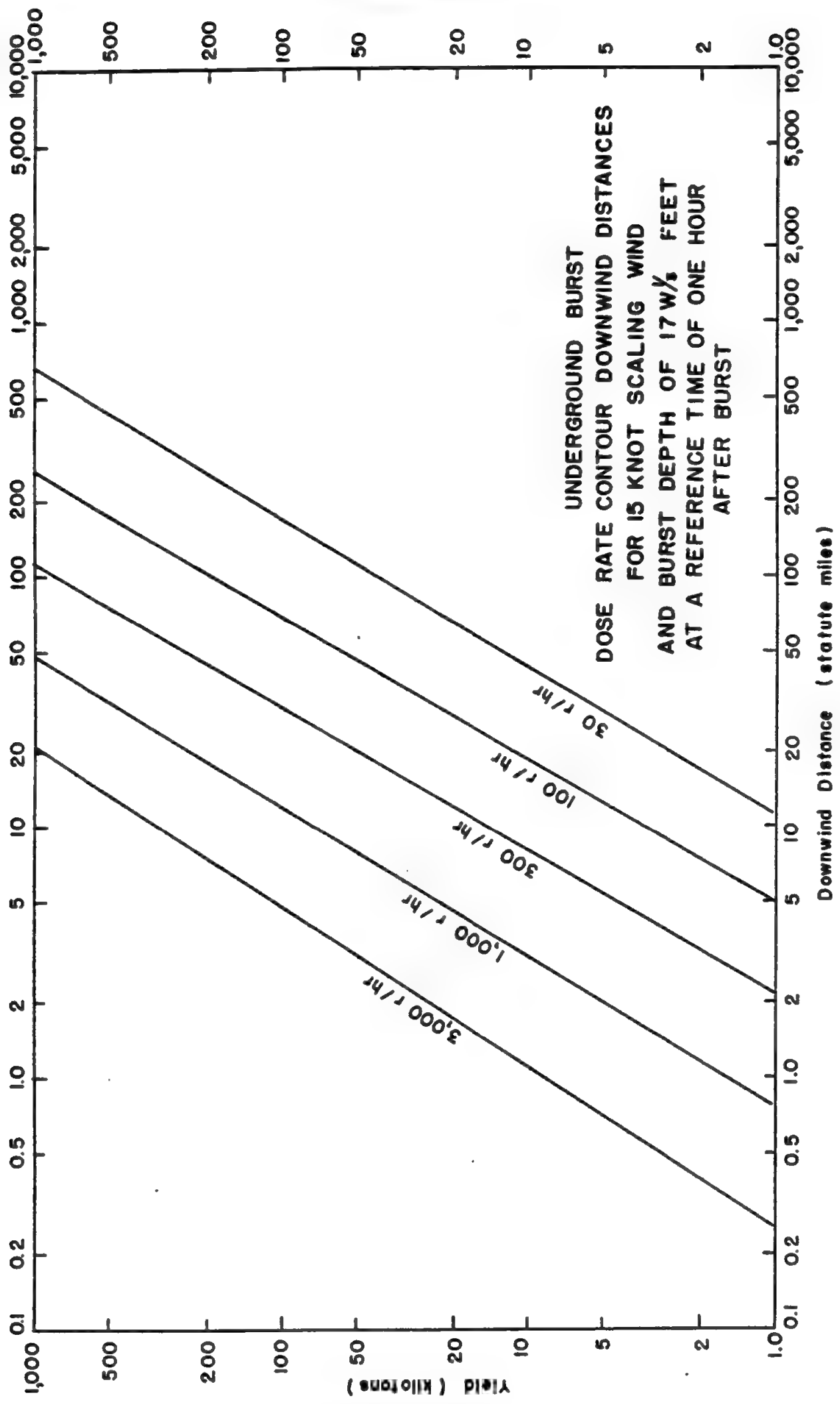

~~CONFIDENTIAL~~

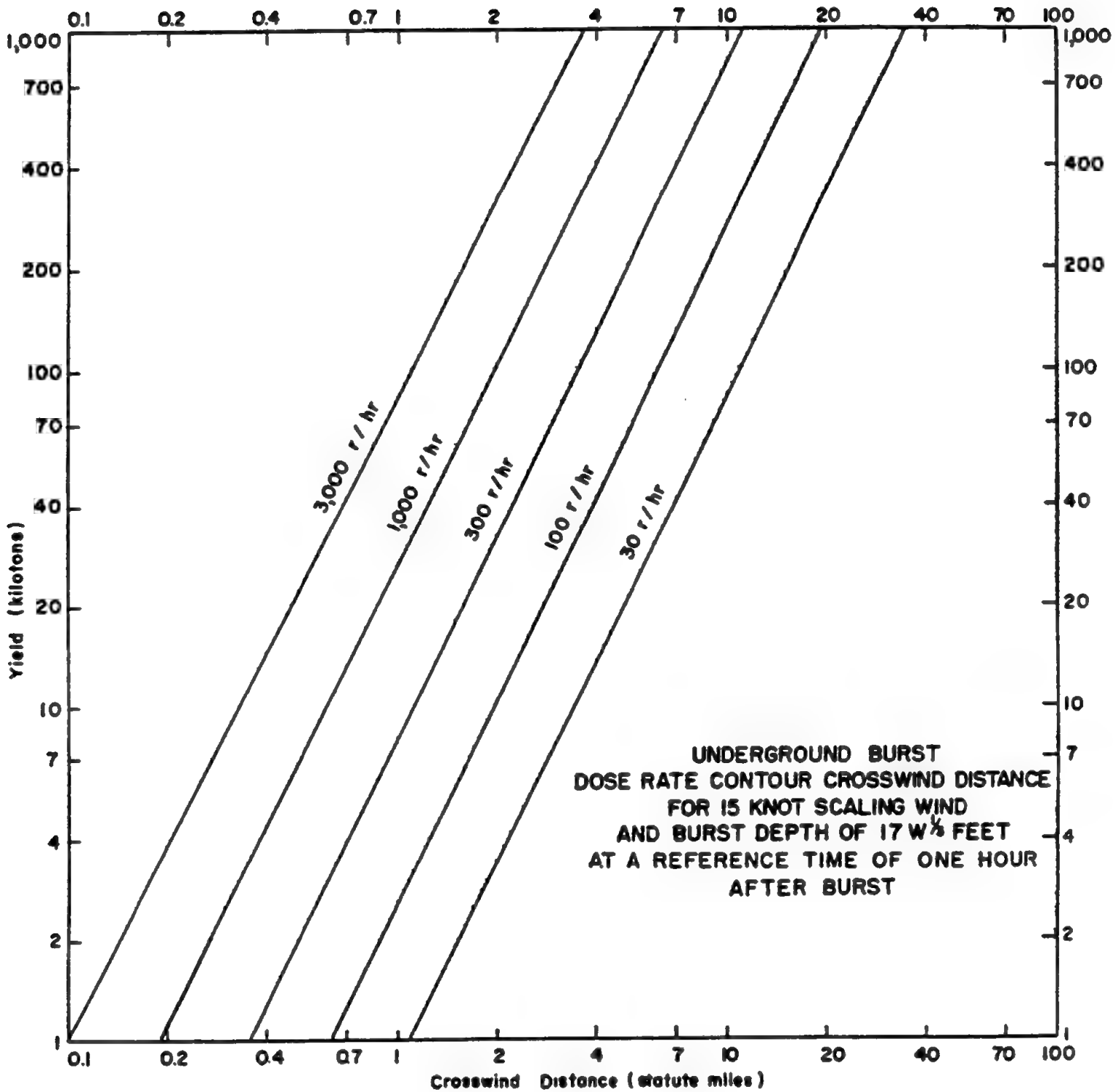

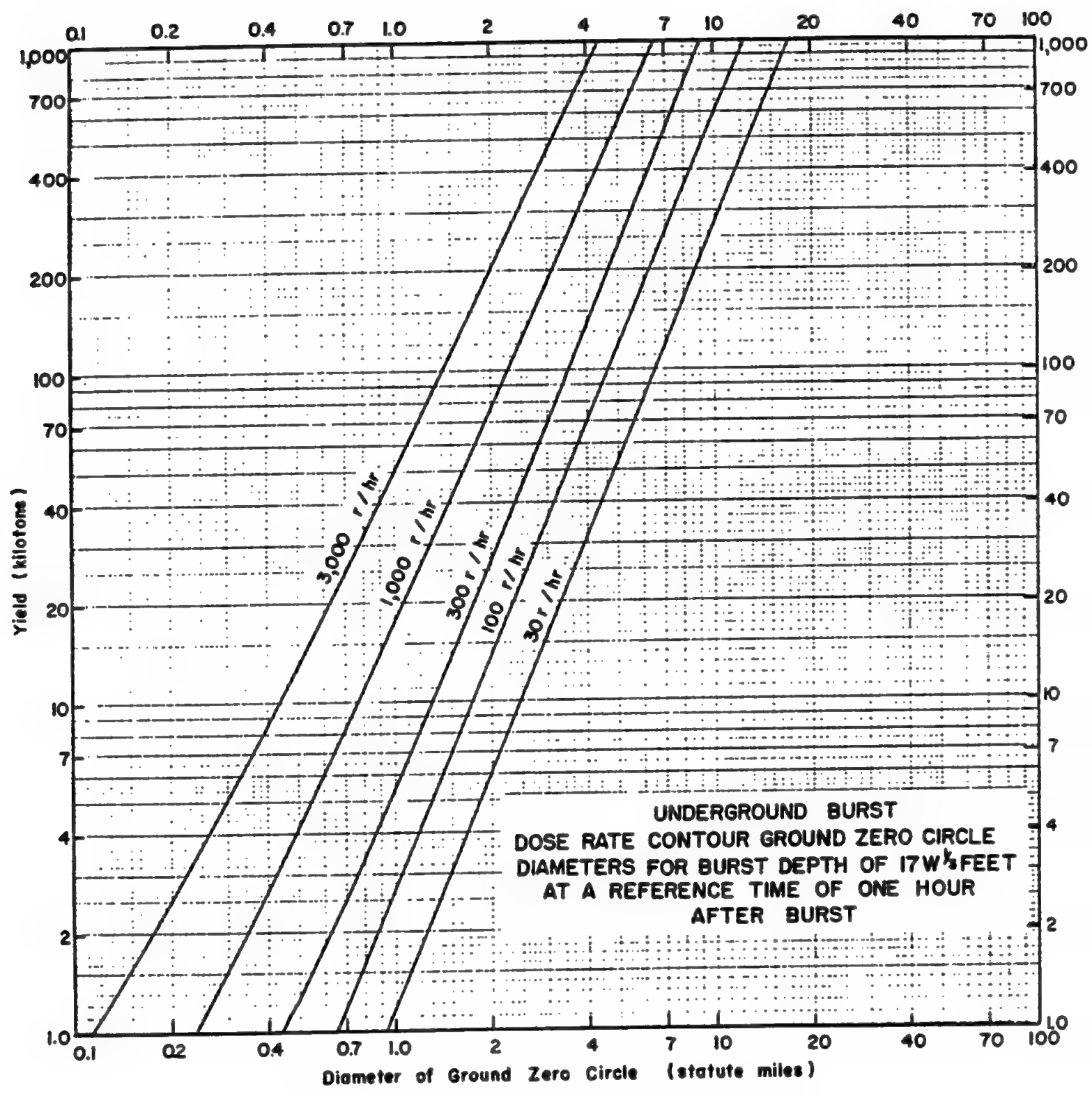

HARBOR BURST DOSE RATE CONTOUR AREAS

Figure 4-25 presents dose rate contour areas to be expected over adjacent land masses at 1 hour after burst time due to residual radiation resulting from bursting nuclear weapons with yields from 1 KT to 1 MT in a shallow harbor. For this purpose, a harbor depth of 30 to 50 feet of water over a mud bottom is assumed, and the burst is assumed to take place a few feet below the water surface, such as in the hold of a ship. The areas given may be assumed to be independent of wind, although specific location of the contaminated areas with respect to the burst point is a sensitive function of wind and other meteorological conditions, as with other types of contaminating bursts. Area magnitudes may be read directly from the curves for those dose-rate values for which curves are provided. Extrapolation to higher or lower dose rate contour values than covered by the families of curves cannot be done

accurately and should not be attempted. To obtain dose rate values for times other than $H+1$ hour, multiplying factors from figure 4-13 should be used.

Example.

Given: A 30 KT harbor burst.

Find: The area of effect for dose rates of 1,000 r/hr or greater at $H+1$ hour.

Solution: Reading directly from figure 4-25, the area for a dose rate of 1,000 r/hr or more at $H+1$ hour for a 30 KT harbor burst is 3.4 (± 1.7) square miles. *Answer.*

Reliability. Area magnitudes obtained from these curves for a specific yield are considered reliable within ± 50 percent for the burst conditions indicated.

Related material.

See paragraph 4.3e.

See also figure 4-13 and figure 4-26.

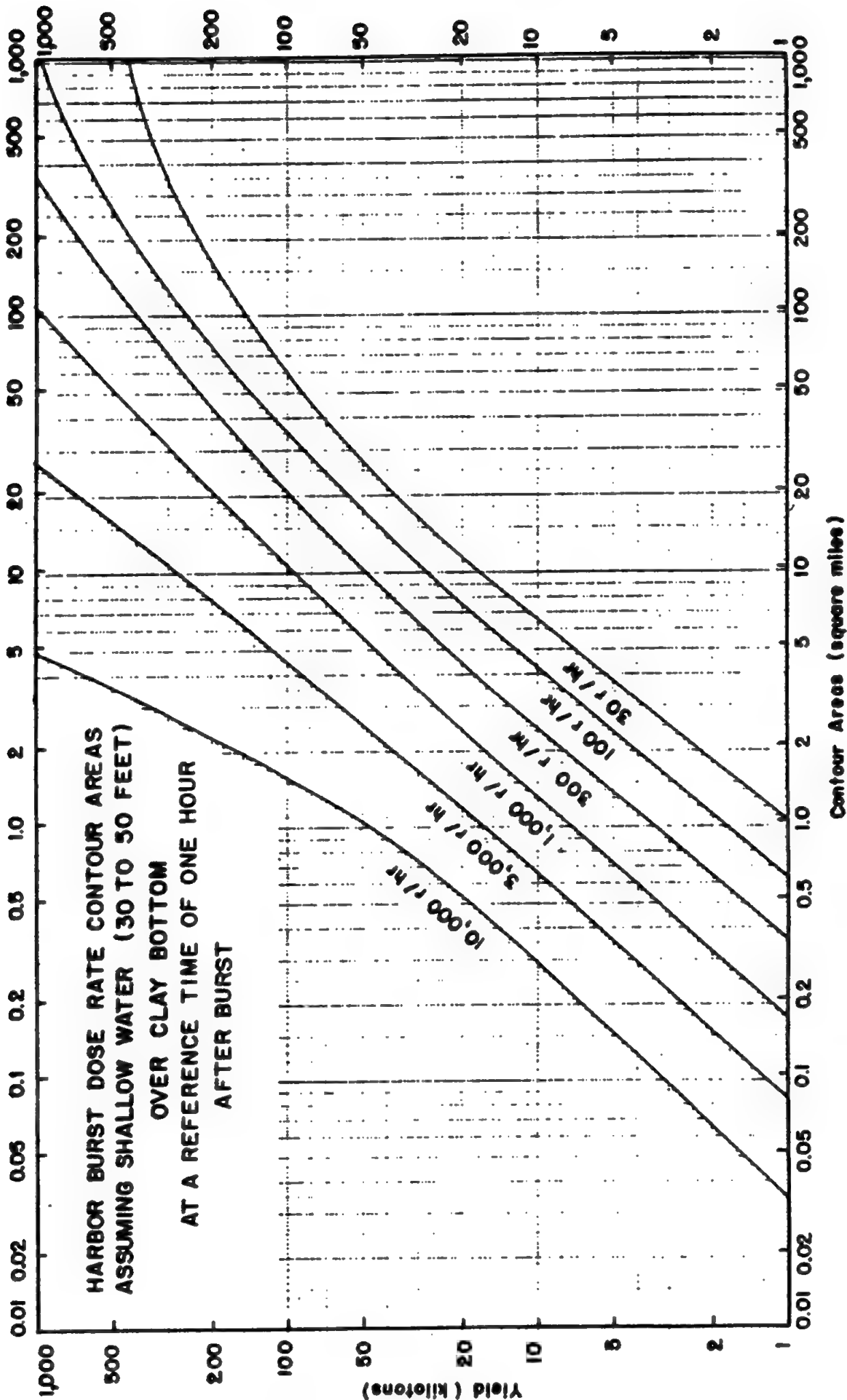

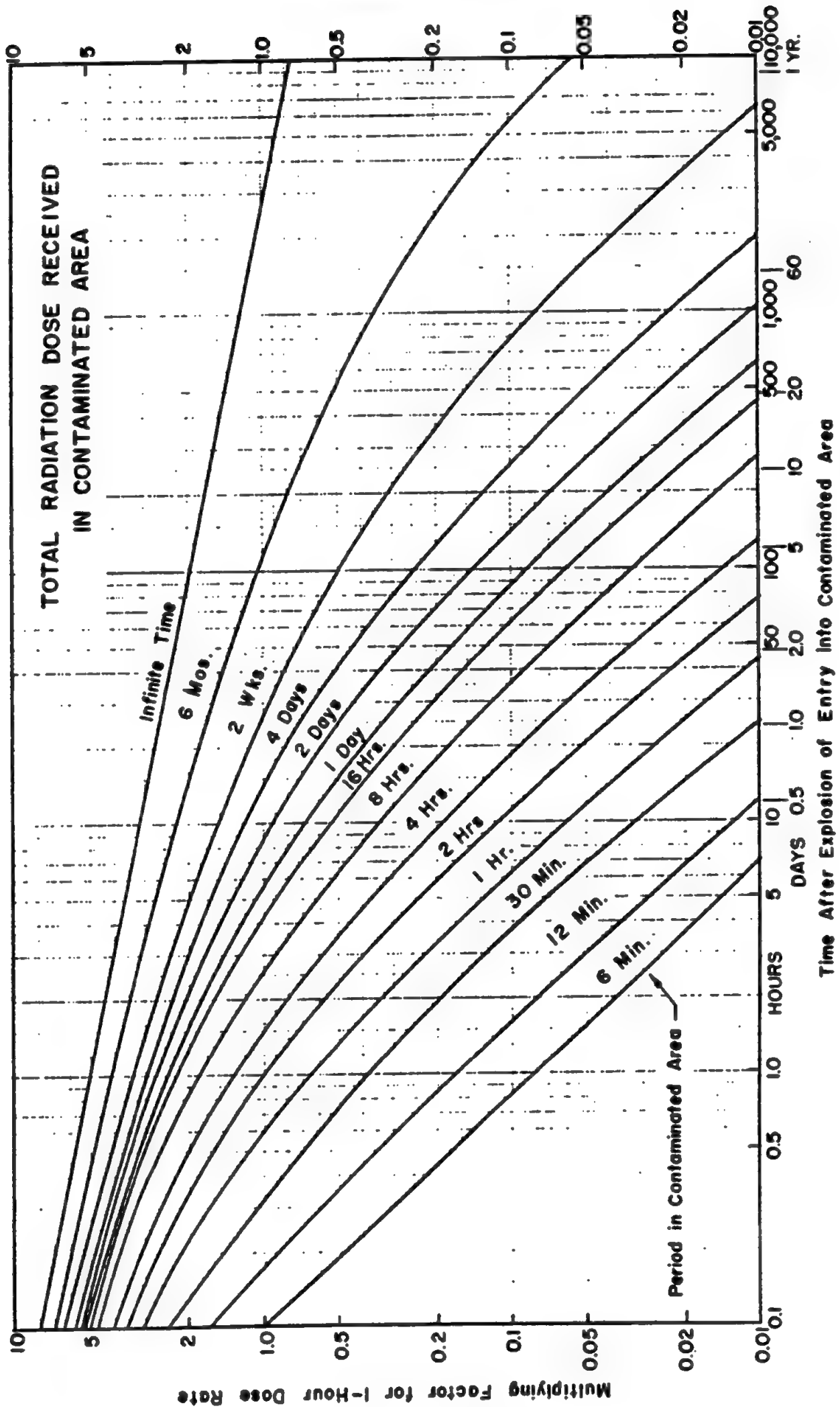

Multiplying Factor for 1-Hour Dose Rate

TOTAL RADIATION DOSE RECEIVED IN CONTAMINATED AREA

Time After Explosion of Entry into Contaminated Area

Period in Contaminated Area

~~CONFIDENTIAL~~

i. *Neutron-Induced Activity.*

- (1) *Air burst.* The neutron-induced gamma activity will depend on soil type as well as weapon type and yield. It is therefore impractical to attempt to define a height of burst above which this effect ceases to be militarily significant.
- (2) *Burst in the transition zone.* If a nuclear weapon is detonated at a height of burst above that at which fallout is expected to be a hazard, the radioactivity which is induced in the soil by neutrons can give rise to dose rates of military importance in the vicinity of ground zero. The type, intensity, and energy distribution of the residual activity produced will depend on which isotopes are produced and in what quantity. This, in turn, depends on the number and energy distribution of the incident neutrons and the chemical composition of the soil. Induced contamination contours are independent of wind, except for some wind redistribution of the surface contaminant, and can be expected to be roughly circular.

Four soils have been chosen to illustrate the extent of the hazard which may be expected from induced activity. These soils were selected so as to show wide variations in predicted dose rates; the activity from most other soils should fall within the range of activities presented for these soils. The chemical composition of the selected soils is shown in table 4-2.

The elements which may be expected to contribute most of the induced activity are sodium, manganese and aluminum and small changes in the quantities of these materials can change the activity markedly; however, other elements which capture neutrons can also influence the magnitude of the activity. The elements are listed in table 4-2 in the order of probable importance so far as induced activity is concerned.

Figures 4-28A and 4-28B indicate the manner in which the induced activity is expected to vary with slant range and

weapon type. $H+1$ hour dose rates for the four soils may be obtained by multiplying the dose rate obtained from figure 4-28A or 4-28B by the multiplying factor for that soil shown on the facing page of these figures.

In order to calculate the dose rates at times other than one hour after the detonation, decay factors may be taken from figure 4-29 which represents the decay characteristics of the four soils. The decay factors are constants which are multiplied by the value of the dose rate at one hour to give the rate at any other time.

Figures 4-30 through 4-33 are presented to facilitate computation of total dose. Multiplying factors may be obtained from these figures which, when applied to the one hour dose rate for the particular soil, will give the dose accumulated over any of several periods of time for various times of entry into the contaminated area.

When applying the data presented in this section to soils other than the four chosen for illustrative purposes, the activity should be estimated by using the data for the illustrative soil which most closely resembles the soil in question in chemical composition. If none of the illustrative soils resembles the soil in question very closely, the following remarks should be kept in mind. For times less than $H+1/2$ hour aluminum is the most important contributor. For times between $H+1/2$ hour and $H+5$ hours, manganese is generally the most important element. In the absence of manganese, the sodium content will probably govern the activity for this period. Between $H+5$ hours and $H+10$ hours, sodium and manganese content are both important. After $H+10$ hours, sodium will generally be the only large contributor. In the absence of sodium, manganese and aluminum, the activity will probably be low, and will generally be governed by the silicon content. Soil type IV is an example of this latter type.

~~CONFIDENTIAL~~

Table 4-2. Chemical Composition of Illustrative Soils

Element	Percentage (by weight)			
	Soil type I (Liberia, Africa)	Soil type II (Nevada desert)	Soil type III (lava clay, Hawaii)	Soil type IV (beach sand, Pensacola, Fla.)
Sodium.....		1. 30	0. 16	0. 001
Manganese.....	0. 008	0. 04	2. 94	
Aluminum.....	7. 89	6. 90	18. 79	0. 006
Iron.....	3. 75	2. 20	10. 64	0. 005
Silicon.....	33. 10	32. 00	10. 23	46. 65
Titanium.....	0. 39	0. 27	1. 26	0. 004
Calcium.....	0. 08	2. 40	0. 45	
Potassium.....		2. 70	0. 88	
Hydrogen.....	0. 39	0. 70	0. 94	0. 001
Boron.....				0. 001
Nitrogen.....	0. 065		0. 26	
Sulfur.....	0. 07	0. 03	0. 26	
Magnesium.....	0. 05	0. 60	0. 34	
Chromium.....			0. 04	
Phosphorus.....	0. 008	0. 04	0. 13	
Carbon.....	3. 87		9. 36	
Oxygen.....	50. 33	50. 82	43. 32	53. 332

Thus, it may be possible to obtain better data for a given soil by using data from a different illustrative soil at each of several times of interest.

If a weapon is burst at such a height as to be in the transition zone from the fallout standpoint, the neutron-induced activity generally can be neglected if the burst height is in the lower three quarters of the fallout transition zone. For weapons burst in the upper quarter of the fallout transition zone the neutron-induced activity may not be negligible compared to fallout. For the cases where fallout dose rate contour parameters, as determined from figures 4-14 through 4-18, are much smaller than those for a burst on the surface, an idea of the magnitude of induced activity may be obtained from figures 4-28 through 4-33. The overall contour values may then be obtained by combining the induced activity and fallout activity. For these cases it must be remembered that fission products and induced activity will decay at different rates. This necessitates a determination of the magnitude of each type of activity for each time of interest.

(3) *Surface and subsurface bursts.* For surface and subsurface bursts, the residual radioactive contamination from fission products is vastly greater than the neutron-induced activity. As a result, neutron-induced activity generally can be neglected for surface and subsurface bursts.

j. Residual Beta Radiation. The discussion of residual radiation has thus far considered only gamma radiation. In general, the hazard due to residual gamma radiation exceeds the beta hazard for all cases except those in which intimate contact with beta-active materials occurs, as in the case of a soldier lying prone in a contaminated area, or for particles falling out directly upon the skin or scalp. For such cases, superficial burns may result, the effect of which is discussed in paragraph 6.3b(3).

k. Shielding. The dose rates obtained from the contours described, and the total doses derived therefrom, are free field values which must be reduced if the individual concerned is protected by some degree of shelter. Shielding factors can be estimated from the shielding information given in paragraph 6.5. For example, personnel in the open in a built-up city area would receive 0.7 of the free field dose, while

NEUTRON-INDUCED GAMMA ACTIVITY

Given the weapon type and the slant range from the point of burst to the point of interest, the induced gamma dose rates in the vicinity of ground zero at $H+1$ hour can be estimated using figures 4-28A and 4-28B for bursts over soils similar in composition to any of the soils illustrated in table 4-2. To estimate the dose rate, enter the slant range axis with the slant distance in yards, read the dose rate for the appropriate weapon type, and multiply this dose rate by the appropriate factor for the soil type of interest from the following:

Soil type	Multiplying factor
I.....	0.11
II.....	1.0
III.....	12.0
IV.....	0.0026

Scaling. For yields other than 1 KT multiply the dose rate read from the curve by the yield in KT.

Example.

Given: An average neutron flux 50 KT weapon is burst at a height of 900 feet above soil of type III.

Find: The $H+1$ hour dose rate at ground zero and at 600 yards from ground zero.

Solution: From the average neutron flux weapon curve of figure 4-28A the dose

rate at $H+1$ hour at ground zero (300 yd. slant range) is 9 r/hr per KT of weapon yield. The multiplying factor for soil type III is 12. Therefore, the dose rate at ground zero one hour after detonation of a 50 KT weapon over soil type III is:

$$50 \times 12 \times 9 = 5,400 \text{ r/hr. Answer.}$$

At 600 yards from ground zero the slant range is 670 yards. From the curve, the induced gamma intensity is 0.35 r/hr per KT of weapon yield at this distance. Therefore, the dose rate 600 yards from ground zero one hour after detonation of a 50 KT weapon over soil type III is:

$$50 \times 12 \times 0.35 = 210 \text{ r/hr. Answer.}$$

Reliability. Dose rate values taken from the curves for the soils presented are correct to within a factor of 5 for the conditions indicated. For other soils, the data will merely furnish an estimate of the magnitude of the hazard.

Related material.

See paragraph 4.3i.

See also figures 4-29 through 4-33.

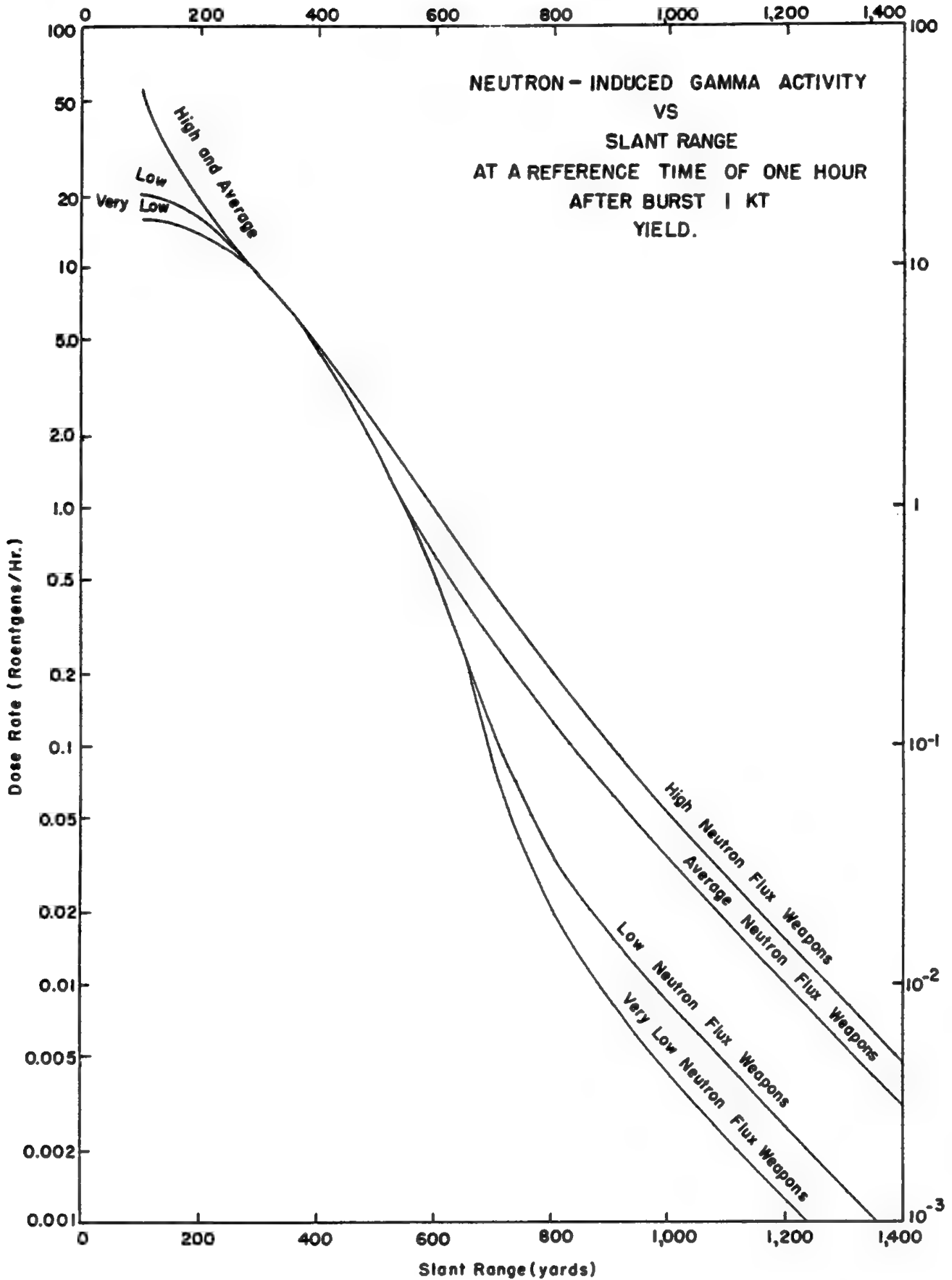

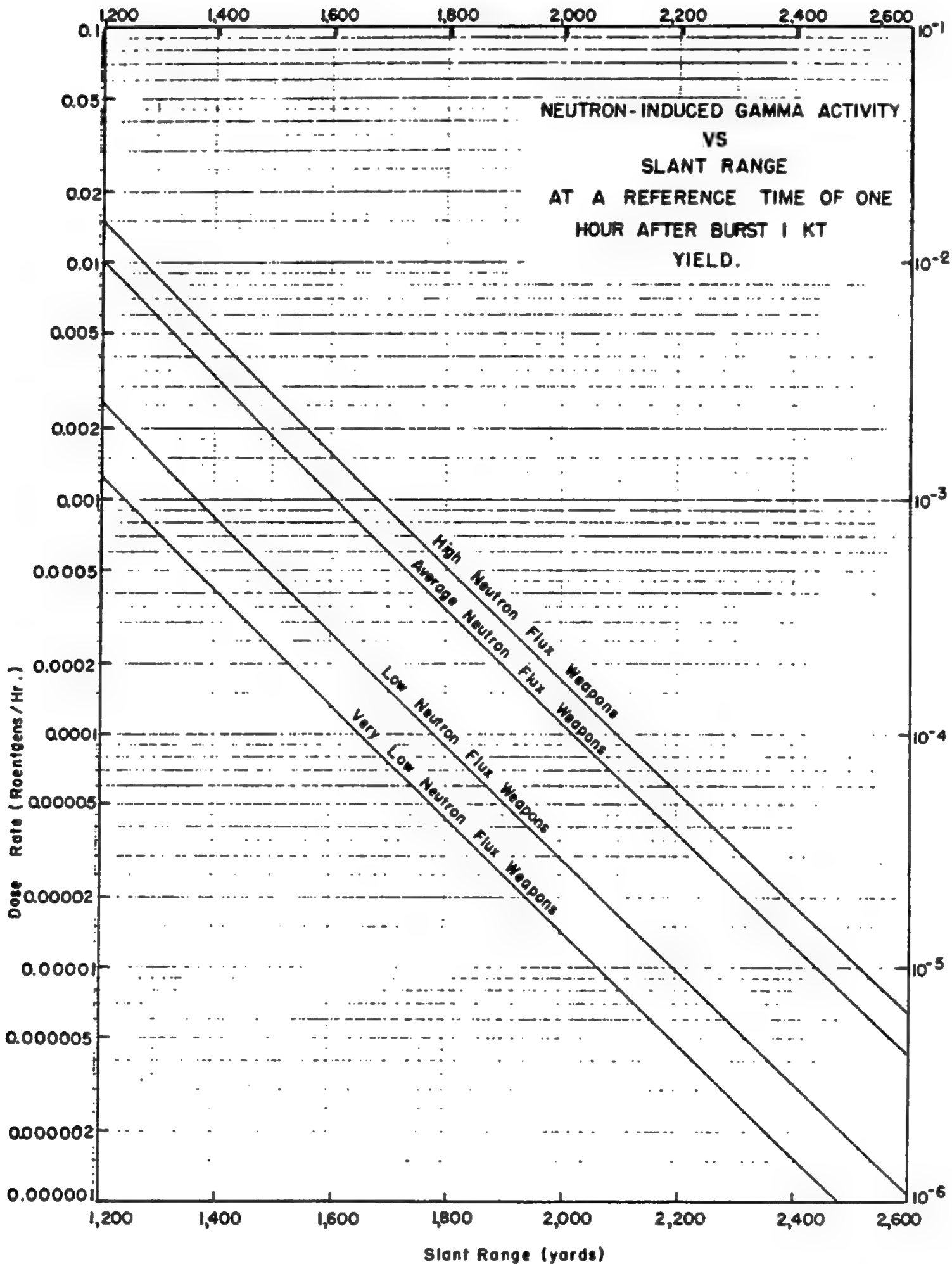

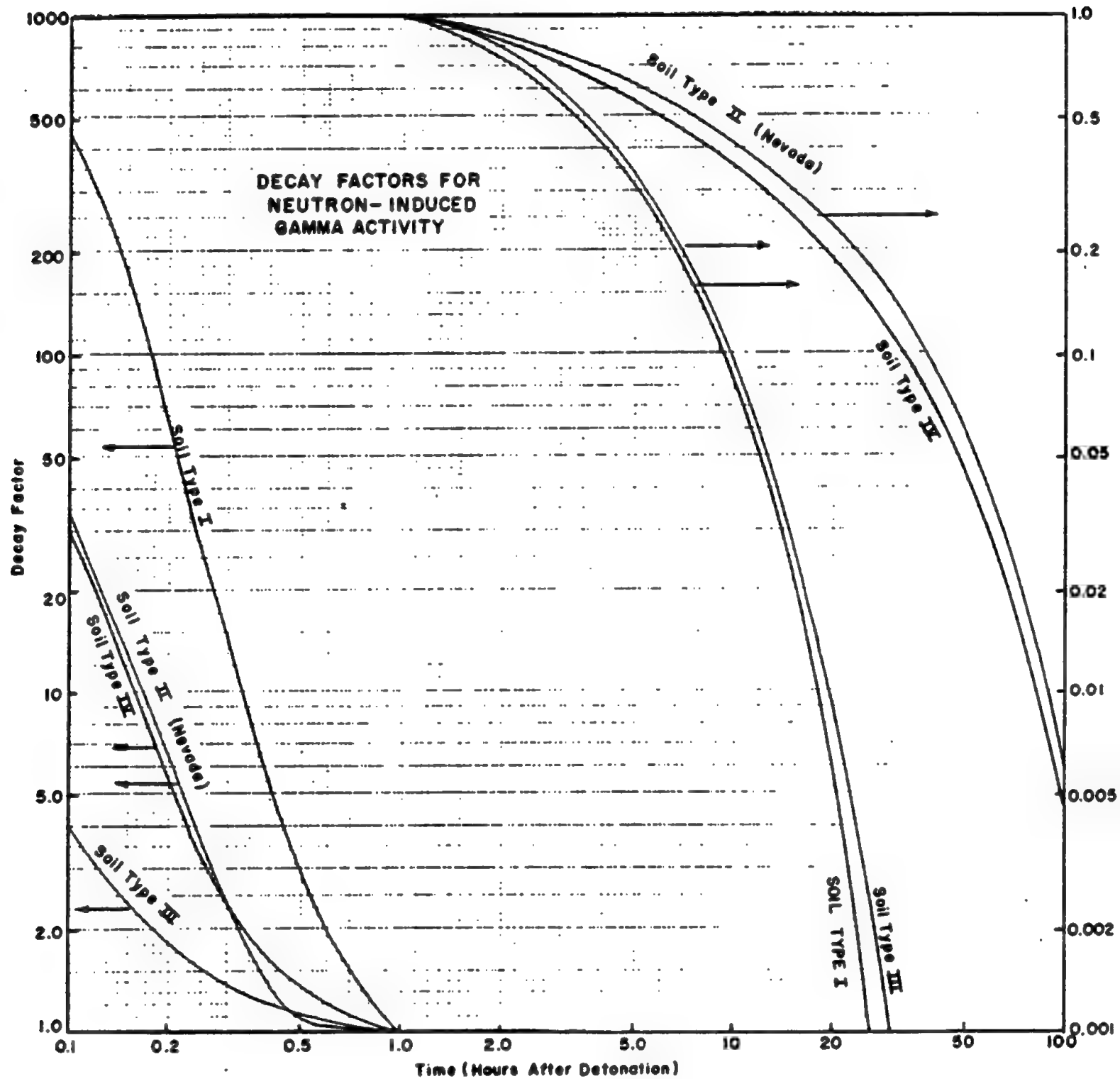

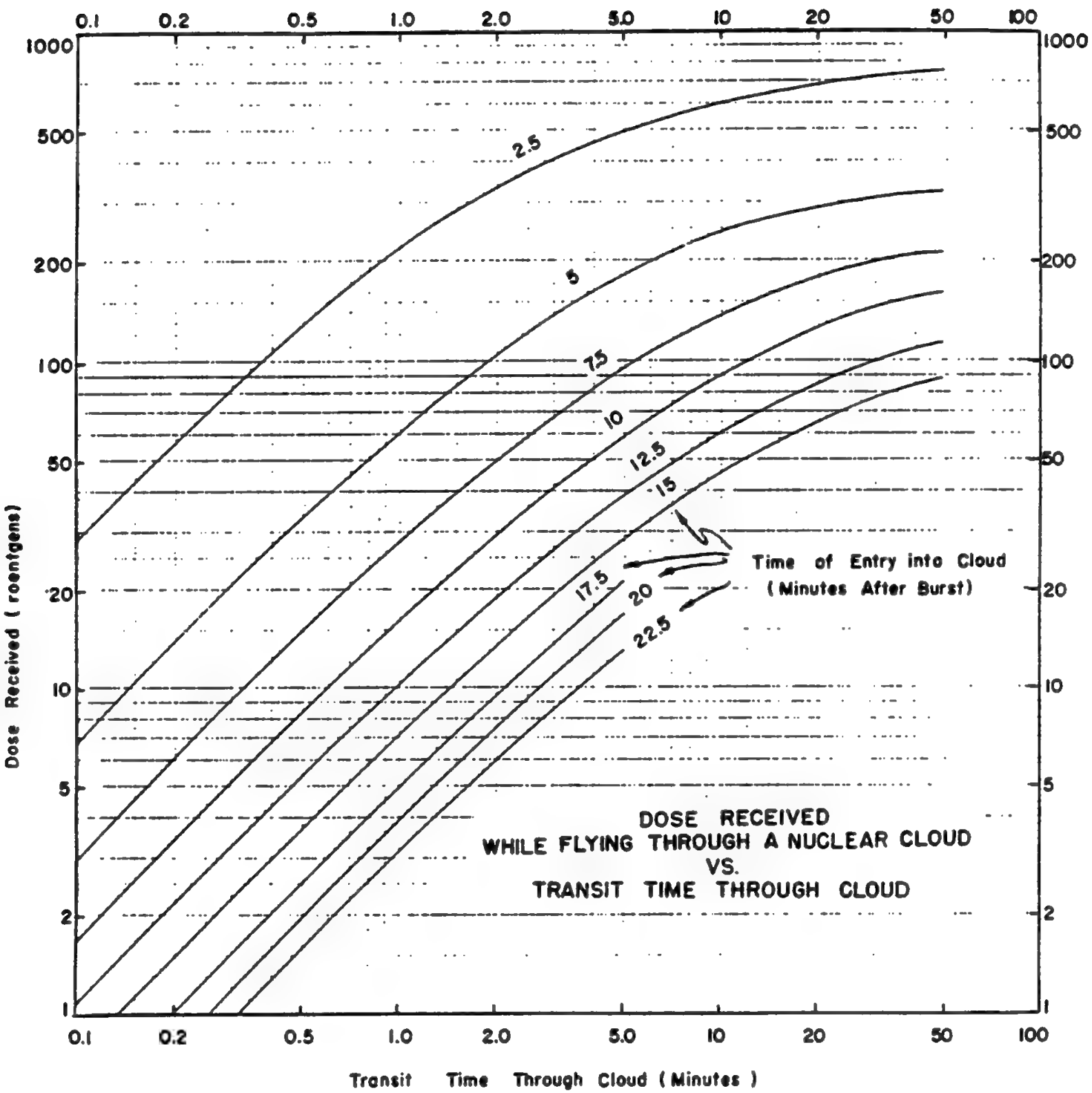

PHENOMENA AT VARIOUS SCALED BURST HEIGHTS

Figures 5-2A, B, and C show the range from ground zero of various physical phenomena when a burst is on the surface, at a scaled height of 250 $W^{1/3}$ feet, and at a scaled height of 650 $W^{1/3}$ feet, respectively. They are presented primarily for rapid visual comparison of the distance to which the various physical phenomena will extend, and secondarily for a rapid determination of the controlling mechanism of damage at any distance for any yield. From data presented in part one, a similar illustration could be prepared for any scaled or actual burst height.

The significance of the various phenomena curves presented varies with the target being considered. The initial and residual radiation curves are the most significant ones for human targets in the open or in shelters. The values chosen for plotting represent the following:

- 5 r —No obvious effect on personnel.
- 100 r —Non-lethal dose causing sickness in a few personnel, but permitting a unit to remain operationally effective.
- 450 r —Dose lethal within 30 days to 50 percent of personnel exposed.
- 10,000 r —Free field dose which will produce a dose of 100 r for personnel within a shelter having a dose transmission factor of 0.01.

The blast and thermal radiation curves cannot be related directly to damage, because of the increasing duration of blast and thermal phenomena with increasing yield and the dependence of the degree of damage sustained on the duration of the damage-producing effect. To assist in relating the curves presented to expected damage, the following table shows the variation with yield of the magnitude of weapon phenomena required to cause various degrees of damage to certain selected targets. (Refer to secs. VI through XII for a more detailed presentation of damage criteria.)

Thermal effects:	1 KT	100 KT (cal/cm ²)	10 MT
Second degree bare skin burn..	4	5.1	9.1
Newspaper ignition.....	2.9	5.1	9.1
White pine charring.....	10	18	32

Thermal effects—Continued	1 KT	100 KT (cal/cm ²)	10 MT
Army khaki summer uniform destruction.....	18	31	56
Navy white uniform destruction.....	34	60	109
Blast effects (in the Mach region):			
Severe damage to overpressure sensitive structures:			
(PSI overpressure)			
Blast-resistant designed buildings.....	50	40	35
Reinforced concrete buildings.....	10.5	9.5	9
Monumental wall bearing buildings.....	20	15	15
Wood frame housing.....	3	3	3
Window pane breakage.....	0.5	0.5	0.5
Severe damage to dynamic pressure sensitive structures:			
(PSI dynamic pressure)			
Light steel frame single story buildings.....	4.5	2	0.9
Heavy steel frame single story buildings.....	6	3	1.5
Steel frame multistory buildings.....	7.5	2.5	0.9
150'-250' span truss bridges.....	50	8	5.5

Some curves are extrapolated beyond data presented in part one, since it is felt that the relationships between phenomena as shown will hold in those regions where there is little supporting knowledge, even though the actual values may be questionable. Since thermal curves are extended beyond one-half the visibility, their interpretation in that region must be approached with caution. In figures B and C, the relative air density would decrease as the actual height of burst is increased in a real case. However, it is held constant for illustrative purposes here. The conversion from slant range to ground range, plus the variation in enhancement of gamma radiation, causes the change in the shape of the radiation curves with change of burst height. Fallout contours are elliptical; only the downwind extent is shown.

Reliability. Varies with the phenomenon of interest. See part one.

Related material.

See paragraph 5.5.

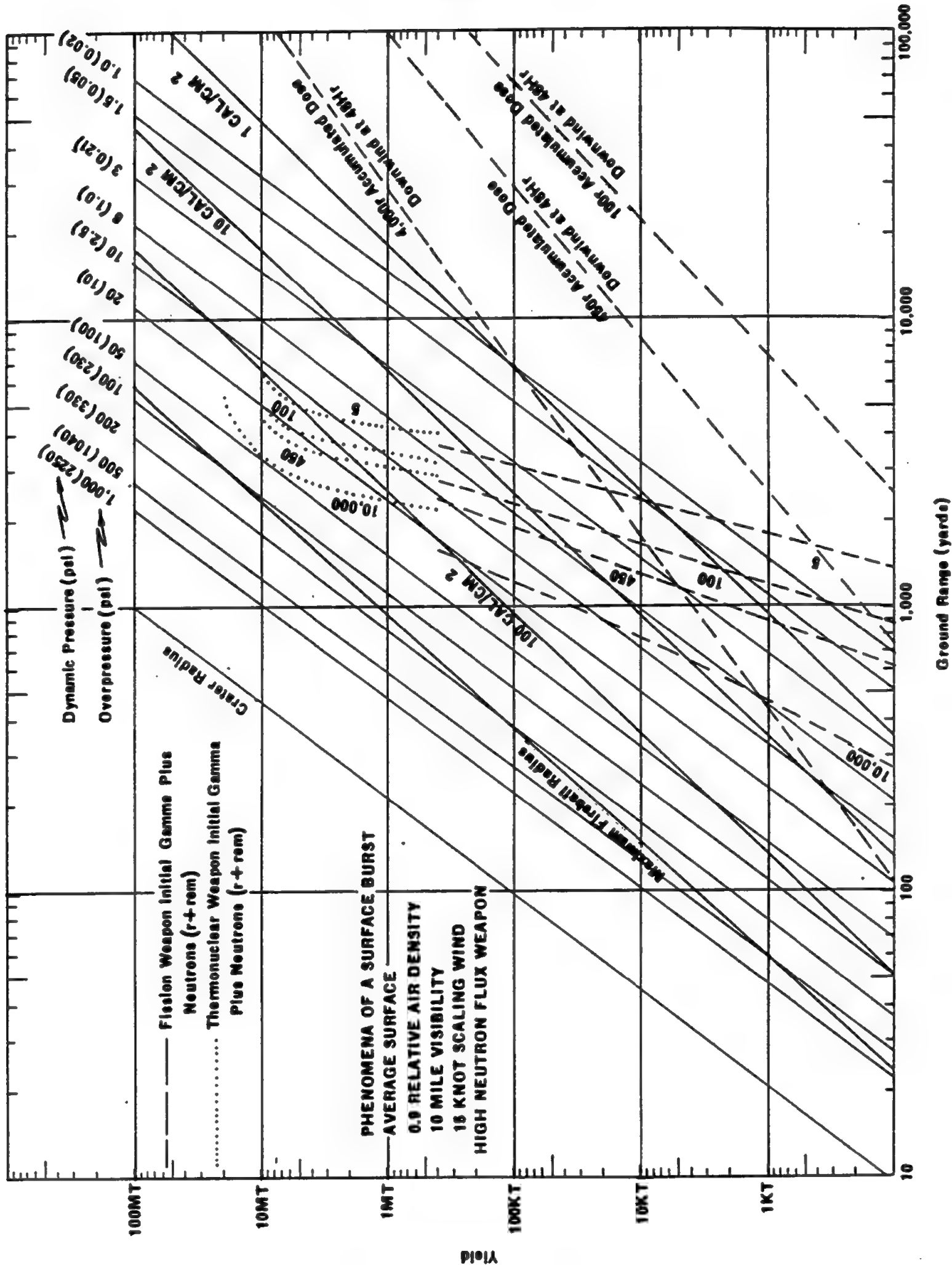

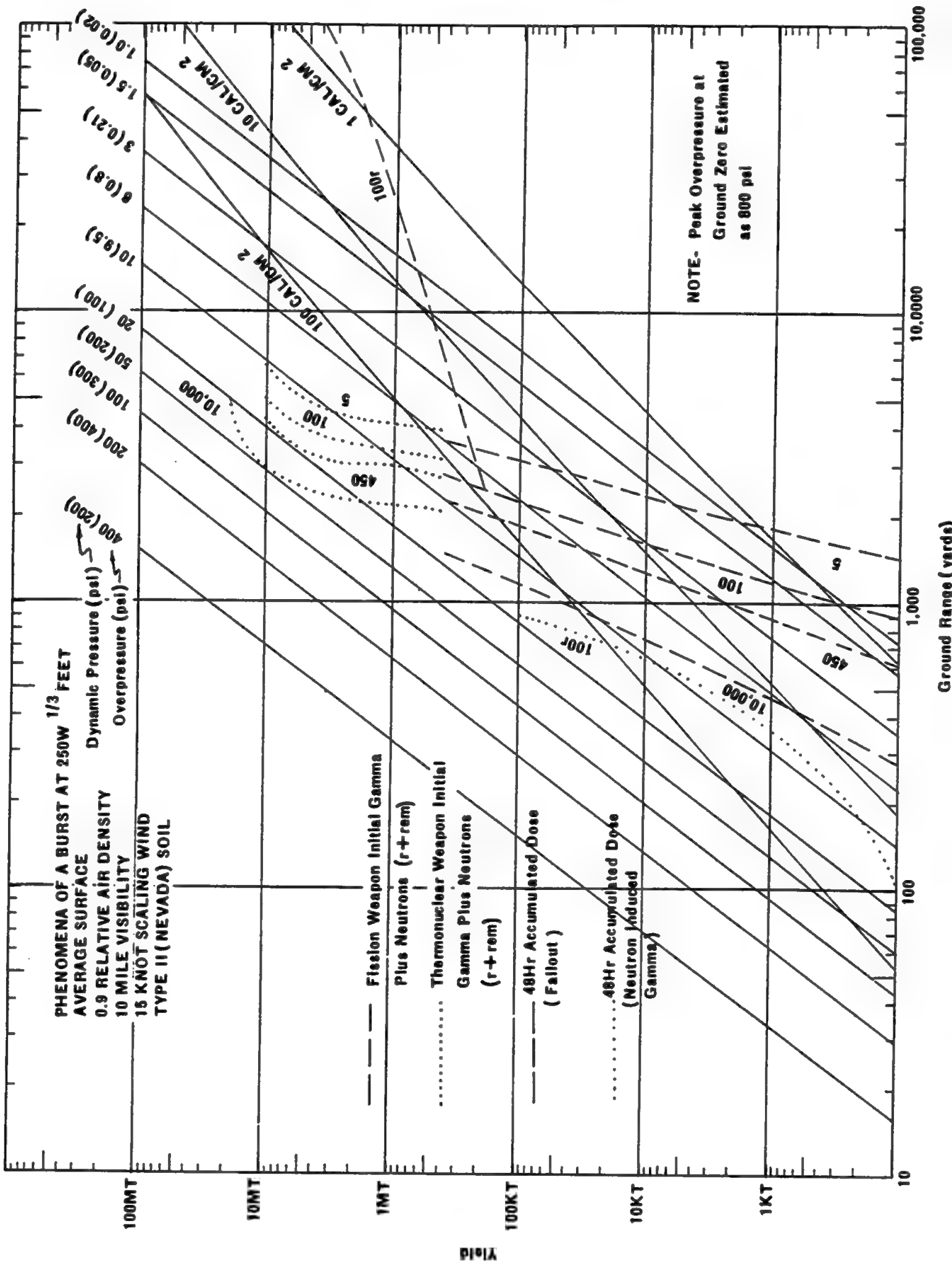

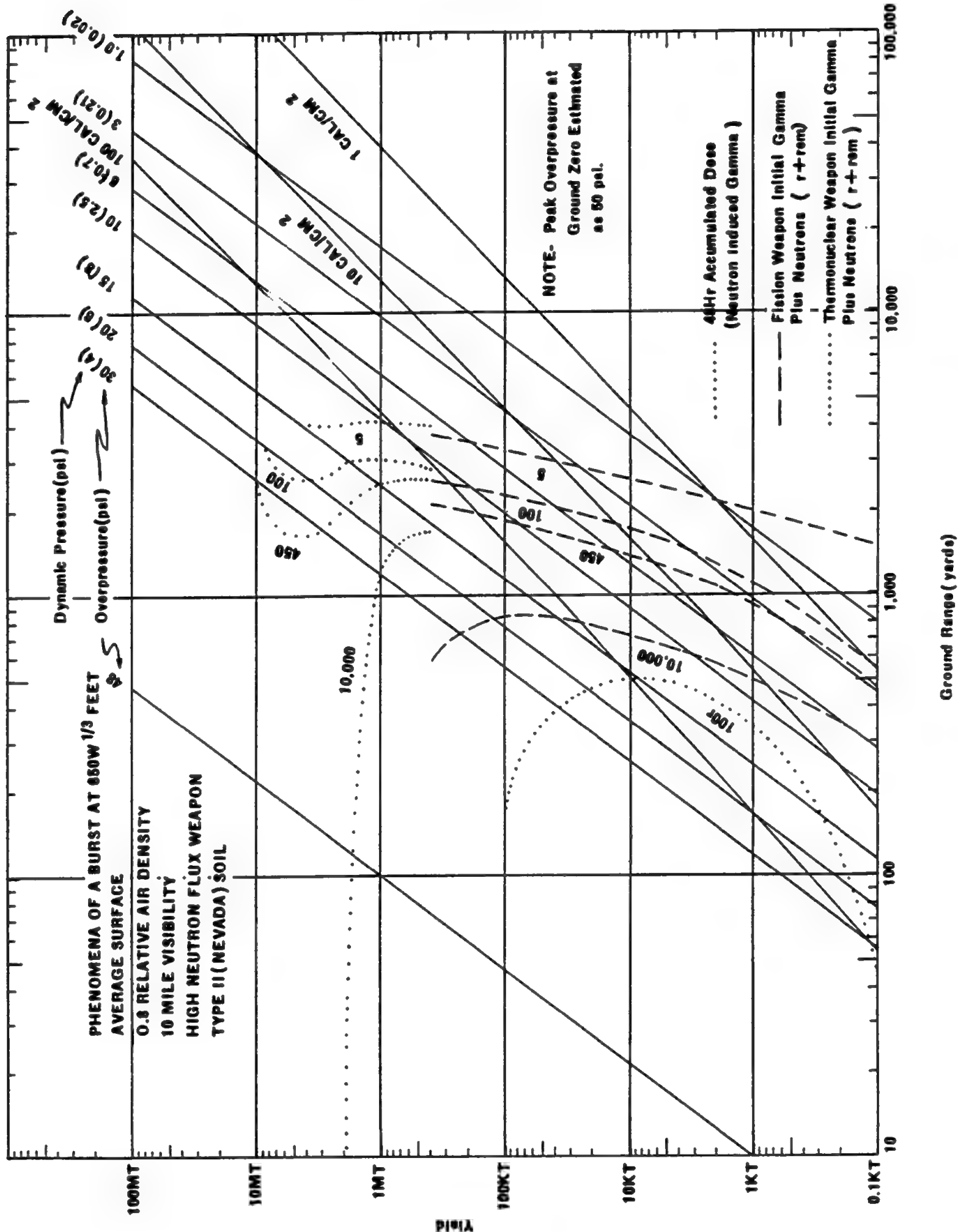

SECTION VI

PERSONNEL CASUALTIES

6.1 Air Blast and Mechanical Injury

a. General. The air blast from a nuclear detonation may cause casualties among human beings in two ways—direct blast injury and indirect blast injury.

b. Direct Blast Injury.

(1) *Crushing forces.* Although the human body is relatively resistant to the crushing forces which result from air blast loading, large pressure differences resulting from blast wave overpressures may cause damage to lungs, abdominal organs and other gas-filled body organs. Based on data obtained from high explosive detonations, it is estimated that on the order of 200 to 300 psi peak overpressure is required to cause death in humans, provided no translational motion occurs. However, the long duration of the overpressure from a nuclear explosion may appreciably lower this peak overpressure criterion. In any event, no crushing injury other than ear drum rupture occurs for a peak overpressure of less than 35 psi. Although ear drum rupture may result from peak overpressures of 7 to 15 psi, this is not considered a disabling injury, and the overall effectiveness of a unit will not be hampered by the occurrence of these injuries. Therefore, since other damage producing effects are overriding at pressures above 35 psi, crushing forces as such need not be considered as a primary mechanism of producing casualties to personnel in the field.

In structures of certain types, such as bomb shelters or permanent type gun emplacements, where adequate shielding exists against thermal and nuclear radiation, the design of the structure may

permit the build-up of blast pressure due to multiple reflections. Blast injuries may therefore occur inside even though the free air overpressure outside the structure would not be sufficient to cause injury.

Both ear drum rupture and other bodily damage which may result from overpressure are largely dependent upon the characteristics of the shock front. If the rise time is long, the body organs are subjected to less severe pressure differences and also are able to better adapt themselves to high overpressure. Consequently, the probability of injury is reduced.

(2) *Translational Forces.*

(a) *Mechanisms.* The translational force to which an individual exposed to a blast wave is subjected depends primarily on drag forces. Since the human body is relatively small and the blast wave almost immediately envelops it, the diffraction process is short. The translational force may be predicted with reasonable accuracy if the burst position, yield, terrain, and the orientation of the human body are known. Since the translational force applied depends on the exposed frontal surface area of the human body, an individual standing in the open is subjected to much larger translational forces than an individual lying on the ground surface. Thus, assuming a prone position at the instant a nuclear bomb flash is detected is quite effective in reducing the likelihood of injuries resulting from bodily translation. In addition, the translational forces are appreciably reduced for an individual

who is behind a building or in a shelter which is sufficiently blast resistant. The degree of protection afforded by a foxhole against injury resulting from translation is not too well known at present. However, appreciable protection should be provided if the foxhole is deep enough to prevent lifting therefrom.

(b) *Criteria for injury.* Although no direct correlation is known between translational motion parameters and injury, it is reasonable to assume that some relationship exists. The initial rate of acceleration, the motions of various parts of the body while being translated, and the nature of the impact, all certainly contribute to injury. Probably most injuries will result from impact. The severity of injury will depend on the nature of the object or objects with which the translated body collides, the nature of the impact, whether glancing or solid, and the velocity at impact. Some individuals may survive a large translation, whereas others may be severely injured or killed by a relatively small translation. Because increased yield results in increased positive phase duration, attainment of velocities sufficient to cause injury on impact will occur for lower peak pressures. The manner of impact likewise depends on the nature of the terrain and surface configuration. If solid impact occurs, it is estimated that body velocities of about 12 feet per second will produce serious injury approximately 50 percent of the time, while collision at about 17 feet per second will result in approximately 50 percent mortality. Figure 6-1 is a plot of burst height vs. ground range at which 50 percent of standing and prone personnel in the open are expected to become direct blast casualties. The curves are drawn for 1 KT and may be scaled to other yields by multiplying the burst heights by the

cube root of the yield and the ground distance by the four-tenths power of the yield.

c. *Indirect Blast Injury.*

(1) *General.* Indirect blast casualties result from burial by debris from collapsed structures with attendant production of fractures and crushing injuries, from missiles placed in motion by the blast wave, or from fire or asphyxiation where individuals are prevented from escaping the wreckage.

(2) *Personnel in structures.* A major cause of personnel casualties in cities is structural collapse and damage. The number of casualties in a given situation may be reasonably estimated if the structural damage is known. Table 6-1 shows estimates of casualty production in two types of buildings for several damage levels. Data from Section VII may be used to predict the ranges at which specified structural damage occurs. Demolition of a brick house is expected to result in approximately 25 percent mortality, with 20 percent serious injury and 10 percent light injury. On the order of 60 percent of the survivors must be extricated by rescue squads. Without rescue they may become fire or asphyxiation casualties, or in some cases be subjected to lethal doses of residual radiation. Reinforced concrete structures, though much more resistant to blast forces, produce almost 100 percent mortality on collapse. The figures of table 6-1 for brick homes are based on data from British World War II experience. It may be assumed that these predictions are reasonably reliable for those cases where the population is in a general state of expectancy of being subjected to bombing and that most personnel have selected the safest places in the buildings as a result of specific air raid warnings. For cases of no prewarning or preparation, the number of casualties is expected to be considerably higher. To make a good estimate of casualty production in structures other

than those listed in table 6-1, it is necessary to consider the type of structural damage that occurs and the characteristics of the resultant missiles. Glass breakage extends to considerably greater ranges than almost any other structural damage, and may be expected to produce large numbers of casualties at ranges where personnel are relatively safe from other effects, particularly for an unwarned population.

Table 6-1. Estimated Casualty Production in Structures for Various Degrees of Structural Damage

	Killed outright	Serious injury (hospitalization)	Light injury (No hospitalization)
	Percent	Percent	Percent
1-2 story brick homes (high explosive data):			
Severe damage.....	25	20	10
Moderate damage.....	<5	10	5
Light damage.....		<5	<5
Reinforced-concrete buildings (Japanese data, nuclear):			
Severe damage.....	100		
Moderate damage.....	10	15	20
Light damage.....	<5	<5	15

Note. These percentages do not include the casualties which may result from fires, asphyxiation, and other causes from failure to extricate trapped personnel. The numbers represent the estimated percentage of casualties expected at the maximum range where the specified structural damage occurs. For the distances at which these degrees of damage occur for various yields, see section VII.

- (3) *Personnel in vehicles.* Personnel in vehicles may be injured as a result of the response of the vehicle to blast forces. Padding where applicable and the use of safety belts, helmets, and harnesses virtually eliminates this source of casualties, at least within armored vehicles. In the absence of these protective devices, serious lacerations may result from impact with sharp projections within the vehicle interiors. Comparative numbers of casualties are almost impossible to assess in this respect due to the many variables which are involved.
- (4) *Personnel in the open.* Missiles translated by the blast wave may be a significant source of injury to exposed person-

nel. Missiles having low velocities, if of sufficient size, may cause crushing injuries. In contrast, penetrating wounds may be caused by high velocity missiles. The missile density and characteristics are largely a function of the target. Where the target area is relatively clean and there is little material present subject to fragmentation and displacement, fewer injuries from missiles are expected in the open than from debris within structures at comparable distances. When the target complex presents many possible sources of missiles this may not be the case. Personnel in a prone position are less likely to be struck by flying missiles than those who remain standing. Those who succeed in getting into bunkers, foxholes, or in defilade probably will achieve almost complete protection from the flying missile hazard.

6.2 Thermal Injury

a. *Introduction.* Before attempting to predict the number of thermal casualties which occur in a given situation, it is necessary to recognize the factors which influence the number and distribution of casualties to be expected. These factors include—the distribution or deployment of personnel within the target area, whether proceeding along a road, in foxholes, standing or prone, in the open or under natural cover; orientation with respect to the bomb; clothing, including number of layers, color, weight, and whether the uniform includes helmets, gloves, or other devices which might protect the bare skin, such as flash creams; and natural shielding. These parameters which define the target must be considered along with the factors which define the source of radiation such as yield of the weapon, height of burst, and visibility, as discussed in section III. In many target complexes, a large percentage of thermal casualties may be due to secondary burns. This is particularly true in cities and industrial areas where a major part of the direct radiation may be shielded by intervening structures. Because of the number of factors involved, it is necessary to analyze each particular target situation in order to make realistic predictions of the thermal casualties to be expected.

b. Primary Radiant Energy Burns. Damage to bare skin through the production of burns may be directly related to the radiant exposure and the rate of delivery of the thermal radiation, both of which are yield dependent. For a given total exposure, as the weapon yield increases, the thermal radiation is delivered over a longer period of time and thus at a lower rate. This allows energy loss from the skin surface by conduction to the deeper layers of the skin and by convection to the air. Thus, a given level of damage also is yield dependent. Critical radiant exposures for the production of two degrees of burn on bare skin as a function of yield are presented in figure 6-2 for normal incidence of radiation. Although the data are presented as a single curve, it must be recognized that there will be variations due to factors such as skin color (i. e., darker skin requires a lesser exposure to produce a given severity of burn) and skin temperature (i. e., colder skin as is found in winter or in arctic climates requires a greater exposure to produce the given burn). The curves represent those radiant exposures which will burn 50 percent of any group, including these variants. A first degree burn is defined as one which shows redness; a second degree burn exhibits partial skin destruction or blistering.

c. Burns Under Clothing. Clothing reflects and absorbs much of the thermal radiation incident upon it and thereby protects the wearer against flashburn. In some cases, the protection is complete, but in many cases it is partial in that clothing merely reduces the severity of injury rather than preventing it. At large radiant exposures, there is the additional possibility that the glowing or ignition of the clothing could deliver additional energy to the skin, thereby causing a more severe injury than bare skin would have suffered. There are many factors which contribute to the degree of protection which clothing affords the underlying skin. The thermal resistance of the clothing material itself is probably the most important, as skin burns under undamaged cloth are rarely seen unless the cloth is in close contact with the skin. Other factors are the weight and weave of the fabric; the number of clothing layers worn; the spacing between layers and between the inner layer and the skin; the moisture content, initial temperature, and color of the cloth; the amount and kind of dirt

in the cloth; the wind velocity and direction across the surface of the cloth; etc.

The complexity of the interrelations among the above factors makes an accurate prediction extremely difficult. Table 6-2 lists various estimates of radiant exposures required to effect burns under clothing. These values are considered representative of some field conditions, within the limitations due to the varying factors described above.

Table 6-2. Critical Radiant Exposures for Burns Under Clothing

(Expressed in cal/cm² incident on outer surface of cloth)

Clothing	Burn	1 KT	100 KT	10 MT
Summer Uniform.....	1°	8	11	14
(2 layers).....	2°	20	25	35
Winter Uniform.....	1°	60	80	100
(4 layers).....	2°	70	90	120

Note. These values are sensitively dependent upon many variables which are not easily defined (see text), and are probably correct within a factor of two.

d. The Combat Ineffective. A useful term in the discussion of effects of thermal radiation on personnel is "the combat ineffective." A combat ineffective is defined as a person who, because of his injuries, is no longer capable of carrying out his assigned tasks. This is differentiated from the more common term "casualty," which is defined as an individual whose injuries require medical attention. Damage to certain areas of the body produces a greater number of combat ineffectives than damage to other areas. Burns in the area surrounding the eyes which eventually cause the eyes to swell shut, and burns to the hands which lead to loss of mobility are particularly apt to cause ineffectiveness.

If a sufficient portion of the total body area is burned, physiological shock follows and the individual becomes a casualty. When more than 10 to 15 percent of the total body area receives second degree burns or worse, shock may be expected. The efficacy of injuries to the hands and eyes in producing combat ineffectives, coupled with the vulnerability of these parts due to lack of protection under ordinary circumstances, indicates the importance of providing protection for these areas when nuclear attack is likely. Table 6-3 presents estimates of the production of combat ineffectives by various degrees of thermal injury.

Table 6-3. Combat Ineffectives Due to Thermal Injury

	1° burns	2° burns
Both eyes.....	Combat effective*	Combat ineffective.
Both hands.....	Combat effective..	Combat ineffective.
15% burns excluding hands and eyes.	Combat effective..	A few ineffectives (10-15%).
25% burns excluding hands and eyes.	Combat effective..	Up to 50% ineffective.

*Some lowering of effectiveness may be expected; however, all should be able to perform combat duties.

e. Thermal Shielding.

(1) *General.* In addition to the protection provided to troops by clothing as discussed above, other possible sources of protection should be considered. Almost any nontransparent material withstands the thermal radiation long enough to afford some shielding to an object behind it. Heavy smoke screens are excellent energy absorbers as described in section III.

Because of the ease of complete shielding from thermal radiation, the amount of forewarning, if any, is of utmost importance to exposed personnel. Covered foxholes or bunkers are excellent thermal shields. The degree to which uncovered foxholes afford protection is related to the height of burst and the distance from ground zero as well as the position of the man within the foxhole. The nearer foxholes offer less protection, since the shadowed portion is a smaller fraction of the total volume. At greater distances from low yield weapons, burns are produced only on those areas subjected to the direct radiation, since reflection from the exposed surfaces of the foxholes may be neglected. Under high megaton burst conditions, a sufficient amount of thermal radiation may be reflected and produce casualties. In highly scattering atmospheres, such as fog or haze, scatter of

the radiation into the foxholes could become an important factor. It is important to note that many targets contain openings such as windows in buildings and aircraft, and ports in tanks and ships. While the general target may not be damaged by external thermal radiation, openings in these targets may allow damaging amounts of thermal radiation to fall on personnel inside.

(2) *Evasive action.* Figure 6-3 demonstrates that evasive action against thermal radiation following the detonation of weapons up to 100 KT is not expected to be successful due to the rapid delivery of the thermal pulse. For weapons in the megaton range, the thermal pulse is delivered over a period of seconds. Significant portions of this pulse may be avoided by simple evasive action such as covering exposed hands and face, or dropping to the ground.

f. Specific Effects on the Eye. Effects of thermal radiation on the eye may be divided into two categories—flash blindness, which is a transitory loss of vision; and retinal burns, which constitute permanent injuries to the retina of the eye. In general, under daylight conditions, flash blindness is not an important factor in estimating effects on personnel. If the flash occurs during daylight in the forward field of vision, impairment to precise vision does not persist for more than 2 or 3 minutes. If not in the forward field of vision, no impairment is expected. During darkness, impairment of vision persists for 5 to 10 minutes if the detonation is in the forward field of view, and for 1 to 2 minutes if not. Loss of dark adaptation persists for longer periods. When the fireball is in the forward field of vision and in clear atmospheres, retinal burns and some degree of permanent loss of visual acuity may occur at relatively great distances from the detonation. Retinal burns have occurred in a few individuals located at distances of 2 to 10 miles from the point of detonation and are theoretically possible at distances where the other immediate effects of the weapon are minimal. This loss of vision is more severe if the eye is focused directly on the point of detonation. As

with flash blindness, this effect is likely to be more severe in situations where the eye is dark-adapted.

g. Secondary Flame Burns and Conflagration Effects may be a source of casualties. Secondary flame burns of the hands and face may occur from ignition of clothing. In areas where conflagrations are likely to result from the detonation, large numbers of burn casualties may occur among individuals trapped in the wreckage of burning buildings or structures, or in forest fires. Under circumstances where conflagrations can occur, individuals in shelters may die of asphyxiation, even though otherwise protected from the other casualty producing effects of the nuclear detonation. After a firestorm or a large scale conflagration begins, it is virtually impossible for an individual to leave the shelter and reach safety through the streets of a burning city.

6.3 Nuclear Radiation Injury

a. General. The radiation effects of a nuclear explosion may be divided into two categories; external radiation (from gamma rays, beta particles, and neutrons) and internal radiation (from gamma rays, alpha and beta particles). The end result in cells receiving doses of these nuclear radiations is qualitatively the same. The effects may be acute or delayed. *Only acute effects will be considered here.* Delayed effects, while important, may not be manifest for years and thus will not affect the immediate military situation.

The essential criterion for injury from ionizing radiation is delivery of the radiation to sensitive body tissues. Thus, external beta radiation affects only the skin, while the penetrating gamma rays and neutrons affect critical tissues within the body. With penetrating radiation from external sources the relationship of the free field dosage to biological effect varies according to the amount of shielding interposed between the source and the critical tissues. In fact, the body itself may shield internal organs from external radiation of low energy or from a single direction.

Radiation can be received in a short time or over an extended period. When received in a short time (i. e., in a few days) the effect is essentially independent of dose rate except for extremely large doses of radiation. (See par. 6.3d on immediate incapacitation.) When received over a long period of time, either continuously or in repeated

doses, biological recovery takes place. This recovery may not be complete, however. It is not possible to specify for the whole body a definite biological recovery rate or a percentage of irreparable damage, since different tissues have different repair rates and different sensitivities to radiation. As an example, the tissue producing one type of white blood cell may repair at the rate of from 2 to 10 percent per day and incur permanent damage of from 10 to 20 percent of the total injury. The skin on the other hand, unless damaged throughout its thickness, may recover functionally 100 percent. Since in the mid-lethal range the state of the blood forming tissues is directly related to survival, it is perhaps reasonable to consider these tissues as representing the whole body response. This is the reason that studies to measure recovery rates and irreparable damage using LD50/30 (the dose lethal to 50 percent of the test population by the end of a 30-day period) as an end point seem to fit an exponential-type function. What is really being measured is a single critical tissue.

b. External Radiation Hazard. The only external radiations of any consequence are gamma rays and neutrons, and under special circumstances, beta particles. During a nuclear explosion the gamma rays and neutrons alone are important, while in a residual fallout field gamma rays and sometimes beta particles must be considered.

- (1) *Gamma radiation* received at the time of detonation is biologically instantaneous. It is from an essentially point source, so is less effective than a corresponding free field dose received from an infinite plane source, such as a residual radiation field. The difference may be expressed thus—in humans an acute free field dose of about 600 roentgens from a point source may be equivalent to about 400 roentgens acute free field dose from a bilateral or an extended source. This dose is currently thought to be the amount required to cause about 50 percent of exposed personnel to die within a month. The best estimates of the effects of various dose ranges in humans are presented in table 6-4.

Table 6-4. Probable Effects of Acute Whole Body Radiation Doses

3

Acute dose (roentgens)*	Probable effect
0 to 50....	No obvious effect except possibly minor blood changes.
80 to 120..	Vomiting and nausea for about 1 day in 5 to 10 percent of exposed personnel. Fatigue but no serious disability.
130 to 170..	Vomiting and nau- <i>ea</i> for about 1 day, followed by other symptoms of radiation sickness in about 25 percent of personnel. No deaths anticipated.
180 to 220..	Vomiting and nausea for about 1 day, followed by other symptoms of radiation sickness in about 50 percent of personnel. No deaths anticipated.
270 to 330..	Vomiting and nausea in nearly all personnel on first day, followed by other symptoms of radiation sickness. About 20 percent deaths within 2 to 6 weeks after exposure; survivors convalescent for about 3 months.
400 to 500..	Vomiting and nausea in all personnel on first day, followed by other symptoms of radiation sickness. About 50 percent deaths within 1 month; survivors convalescent for about 6 months.
550 to 750..	Vomiting and nausea in all personnel within 4 hours from exposure, followed by other symptoms of radiation sickness. Up to 100 percent deaths; few survivors convalescent for about 6 months.
1,000.....	Vomiting and nausea in all personnel within 1 to 2 hours. Probably no survivors.
5,000.....	Incapacitation almost immediately. All personnel will be fatalities within 1 week.

* (1) And/or rem in the case of neutrons. See discussion in paragraph 6.3b(2).
 *(2) Continuing investigations indicate that these ranges may be low for corresponding effects by a factor of 2.

(2) *Neutrons*, like the gamma rays, are delivered essentially instantaneously at the time of a nuclear explosion. There is some evidence that in animals the size of a man, neutrons are less effective than hitherto supposed because of rapid attenuation in superficial tissues. The following discussion will depend on an understanding of certain units and terms used in the evaluation of biologically hazardous doses of radiation.

The roentgen equivalent physical (rep) is defined as that dose, of any ionizing radiation, which will produce in a unit

volume of the irradiated substance, the same energy absorption which would be produced in the same substance by a roentgen of gamma or X-rays. Inasmuch as different radiations, even though producing the same energy absorption per unit volume, have different effectiveness in producing biological injury, the relative biological effectiveness (RBE) of these various radiations must be taken into account. If, for example, it is found that a rep of neutrons causes 30 percent more damage than a rep of gamma rays, it is said that such neutrons have an RBE of 1.3. X-rays produced at 250 KVP (kilo-volt peak) are assigned an RBE of 1.0, and the hazard of the other radiations is measured in terms relative to the effectiveness of X-rays for producing injury. One can then multiply the reps of any other ionizing radiation by the appropriate RBE to get another unit of dose which is directly proportional to the biological damage, i. e., the roentgen equivalent mammal (rem)—

$$(rep) \times (RBE) = (rem).$$

Rem, correctly measured for each type of ionizing radiation, may be added to obtain the total dose. See paragraph 5.4.

Physical dosimetry of neutrons, however, is difficult. The most consistent indicator which responds to the largest biologically important portion of the bomb neutron spectrum is reduction in weight of the spleen and thymus of mice. This measure serves as a basis for comparing gamma rays and neutrons in a biological system in terms of rem. This rem unit applies strictly to this effect, and it may well be that acute effects in man are not predictable on the basis of presently available data.

The curves of neutron dose given in part one, figures 4-10 and 4-11, give the dose directly in rem, an RBE of 1.3 for whole body neutron radiation

having been assumed in preparing the curves. Therefore, the neutron dose in rem determined from figure 4-10 or 4-11 may be added directly to the gamma dose in roentgens obtained from one of the figures 4-1 through 4-8, and the total dose so determined used in conjunction with table 6-4 to estimate the probable overall effects of the immediate nuclear radiations.

(3) *Beta particles.*

(a) *General.* Beta particles, as well as gamma rays, constitute an external hazard from residual contamination. In an extended field of fallout radiation the gamma hazard generally far outweighs that from beta particles. However, the beta hazard may become quite important in certain circumstances, such as—

A person receives fallout particles directly on the body, or lies on a contaminated surface.

Personnel are located in a relatively confined area which has been subjected to fallout, and surrounding structures provide shielding from much of the gamma radiation, as would be the case in a narrow city street.

Fallout particles are removed from the extended field into a new environment, but remain in close proximity to personnel.

(b) *Effect.* Beta particle penetration is quite limited and may be partially blocked by thin absorbers such as clothing. Due to the limited range of beta radiation, the skin is the only structure directly affected. Mammals may be killed by total surface beta radiation, however. The amount required for an LD50/45 is inversely proportional to the area/mass ratio (i. e., the amount of skin in relationship to the rest of the body). Small mammals are quite sensitive, there being a good correlation between species in this regard. On this basis man *might* require about 40,000 rep over

his whole body surface before entering the mid-lethal range.

It should be pointed out, however, that the LD50 is a poor end point for evaluation of a skin damaging process, and that large area injuries would be highly incapacitating, though not necessarily lethal, within a short period of time. A total surface beta injury is an extremely unlikely possibility. The typical human beta injuries from residual contamination are multiple ones, on surfaces directly exposed to the material. These indicate that direct contact is usually necessary for this type of "beta burn".

(c) *Decontamination.* Where personnel have been exposed to direct contact with radioactive fallout particles, a few simple measures greatly reduce the probability of development of beta burns. Immediate showering, bathing, or simple removal by brushing off the particulate matter, accompanied by securing shelter and donning clothing of a protective nature (long-sleeved shirts, cover-alls, shoes, etc.) affords sufficient protection against the beta burn hazard. The longer the fallout remains in contact with the skin, the more severe and extensive the beta burn is likely to be.

c. *Internal Radiation Hazard.*

(1) *General.* The hazard associated with the intake of radioactive material into the body is present only in cases where fallout occurs. In such instances radioactive elements may be breathed into the lungs or may be swallowed and absorbed from food and water. The vast majority of the radioactive elements which are inhaled do not remain in the lung, because particles must be within a limited size range to be retained. Only a small fraction of the retained particles are likely to be concentrated and fixed in the lung. Swallowed and inhaled elements must be soluble to become absorbed. Once absorbed, these elements are handled in exactly the same manner as are the cor-

responding non-radioactive elements. Thus, they are eliminated from the body at various rates, with some being concentrated in certain locations for long periods of time. It is this prolonged retention of some radioactive fission products that characterizes the internal hazard.

(2) *Importance.* The significance of internal radiation in terms of *immediate* effects is negligible, since the external gamma hazard in the residual field of fallout contamination is the controlling factor in determining the danger to personnel. The same condition holds for the passage of aircraft through a radioactive cloud. Following the contaminating incident in the Marshall Islands in March 1954, a great quantity of data regarding the hazard associated with internal sources was obtained. In spite of the facts that the Marshallese people lived under conditions where the maximum probability of contamination of food and water supplies existed, and that they took no steps to protect themselves in any way, the degree of internal hazard due to fallout was small.

(3) *Protective measures.* Gas masks, air filters, or even handkerchiefs are effective in removing the particulate matter from inhaled air. Various methods of water decontamination have been proposed and evaluated, resulting in certain effective processes. Distillation, coagulation, filtration, adsorption and ion exchange may all be used advantageously. The Army Engineers' Erdlator units are of particular value. This equipment, which utilizes the processes of coagulation, diatomite filtration and disinfection, is ordinarily used to treat and purify surface waters in the field. When used for radioactive decontamination, a 50-85 percent removal of dissolved gross fission products may be expected when the unit is operated in conventional fashion. The removal can be increased to 93 percent with a clay pre-treatment and to over 99.9 percent with an ion exchange post-treatment. The Mobile Water Purifica-

tion Unit (Erdlator) may be expected to remove essentially all of the radioactivity present in the form of turbidity or particulates. Canned and covered food and water are not contaminated by fallout. Directly contaminated food may be used when necessary by cutting or scraping off the outer layers.

d. Immediate Incapacitation. There are direct effects of massive, rapidly administered doses of radiation on the vital organs which result in early nausea, vomiting, and loss of ability to perform purposeful actions due to lack of coordination and imbalance. These symptoms may be sufficiently severe to result in immediate incapacitation of an individual to such a degree that he is not able to perform his duties. Experimental animal data indicate the onset of incapacitation by the end of 3 to 7 minutes, but the delay may be even less in the case of very high dose exposures from a nuclear explosion. Extrapolation of experimental data to man in this case is extremely difficult. It appears that on the order of 5,000 roentgens or rem from initial radiation may be sufficient to cause immediate incapacitation, but experimental evidence suggests the possibility of a temporary partial recovery from such doses after about 15 minutes. It is not known whether this partial recovery would result in the individual again becoming combat effective. With doses on the order of 15,000 to 20,000 roentgens, even the transient recovery period is unlikely and death may occur within a few hours.

6.4 Combined Injury

Any combination of moderate but sublethal exposures to thermal or nuclear radiations and/or mechanical injury is expected to produce more casualties or greater lethality than any effect considered singly, due either to additive effects or even to mutually reinforcing (synergistic) effects. Figure 6-4 represents a comparison of the ranges of the three effects considered individually in one situation. Insufficient data precludes the presentation of any summation curve at this time.

6.5 Nuclear Radiation Shielding

a. General. The gamma radiation dosage actually received by an individual is reduced if

absorbing material is located between the individual and the point of detonation. Thus, the dose received by a person behind a building, in a field fortification, in a tank, or in a ship is less, and in some cases much less, than that which would be received in an exposed position at the same distance from the detonation. The shielding under such circumstances is generally discussed in terms of a "dose transmission factor", defined as the ratio of the dose received behind shielding material to the dose which would be received in the absence of the shielding.

b. Initial Radiation. The determining factors in the effectiveness of shielding are the mass of the material between the source of radiation and the target; the energy distribution of the gamma radiation at the target; the distance from the source, which partly determines the gamma energy distribution; the angle of the incident radiation; and the geometry of the shielding itself. Some of these parameters are combined in figure 6-5 to give a series of curves of the dose transmission factor as a function of shielding thickness for various materials. The curves are based on the assumption that the radiation is perpendicular to the slab of shielding material. Since gamma rays are scattered considerably in air, the resultant dose transmission factor holds strictly only for slab shields so large that no radiation can get

around the edges. To insure sufficient protection against radiation scattered from all directions, shielding material should be used for all exterior surfaces. The curves of figure 6-5 are applicable for yields between 0.1 KT and 100 KT. For yields above 100 KT, the curves are considered to be a conservative estimate of attenuation of initial gamma radiation (i. e., the transmission is even less than indicated), because the initial spectrum received at the target contains a higher proportion of low energy gamma rays, and is therefore less penetrating. Dose transmission factors are given in table 6-5 for particular situations, such as personnel in tanks, foxholes, houses, buildings, and basements.

c. Residual Radiation. Residual radiation is somewhat less penetrating than initial radiation, as can be seen from the dose transmission curves for residual radiation in figure 6-6. In the case of residual radiation from a contaminated ground surface, the most effective location for shielding material is between the receiver and the contaminated ground, such as the floor of a tank, or the ceiling of an underground shelter. Some shielding against residual radiation is afforded by walls also, since a portion of the radiation received can come horizontally from points up to several hundred yards from the receiver.

Table 6-5. Dose Transmission Factors (Interior Dose/Exterior Dose)

Geometry	Gamma rays		Neutrons *
	Initial	Residual	
Foxholes ^b	0.05-0.10	0.02-0.10	0.3
Underground—3 feet.....	0.04-0.05	0.0002	0.002-0.01
Built-up city area (in open).....		0.7	
Frame house.....	0.9	0.3-0.6	0.9-1.0
Basement.....	0.05-0.5	0.05-0.10	0.1-0.5
Multistory building:			
Upper.....	0.9	0.01	0.9-1.0
Lower.....	0.3-0.6	0.1	0.9-1.0
Blockhouse walls:			
9 inches.....	0.1	0.05	0.3-0.5
12 inches.....	0.05-0.09	0.01-0.02	0.2-0.4
24 inches.....	0.01-0.03	0.001-0.002	0.1-0.2
Factory, 200 x 200 feet.....		0.10-0.20	
Shelter, partly above grade:			
With earth cover—2 feet.....	0.02-0.04	0.005-0.02	0.02-0.03
With earth cover—3 feet.....	0.01-0.02	0.001-0.005	0.01-0.03
ARMY (b)(1)			
LVT (Landing Vehicle Tracked).....	0.5-0.9		1.0
Battleships and large carriers *:			
15% of crew.....	1.0	1.0	0.8-1.0
25% of crew.....	0.2	0.1	0.2-0.5
10% of crew.....	0.05	0.03	0.05-0.2
50% of crew.....	0.0005-0.005	0.0003-0.003	0.001-0.05
Cruisers and carriers *:			
10% of crew.....	1.0	1.0	0.8-1.0
20% of crew.....	0.5	0.3	0.4-0.5
30% of crew.....	0.1-0.3	0.1	0.1-0.4
40% of crew.....	0.005-0.1	0.003-0.05	0.01-0.1
Aircraft.....	1.0		1.0
Destroyers, transports, and escort carriers *:			
10% of crew.....	1.0	1.0	0.8-1.0
20% of crew.....	0.7	0.5	0.6-0.5
30% of crew.....	0.4	0.2	0.3-0.6
40% of crew.....	0.1-0.4	0.1	0.1-0.3

* Estimated values.
^b No line-of-sight radiation received.
 * Crew at General Quarters.

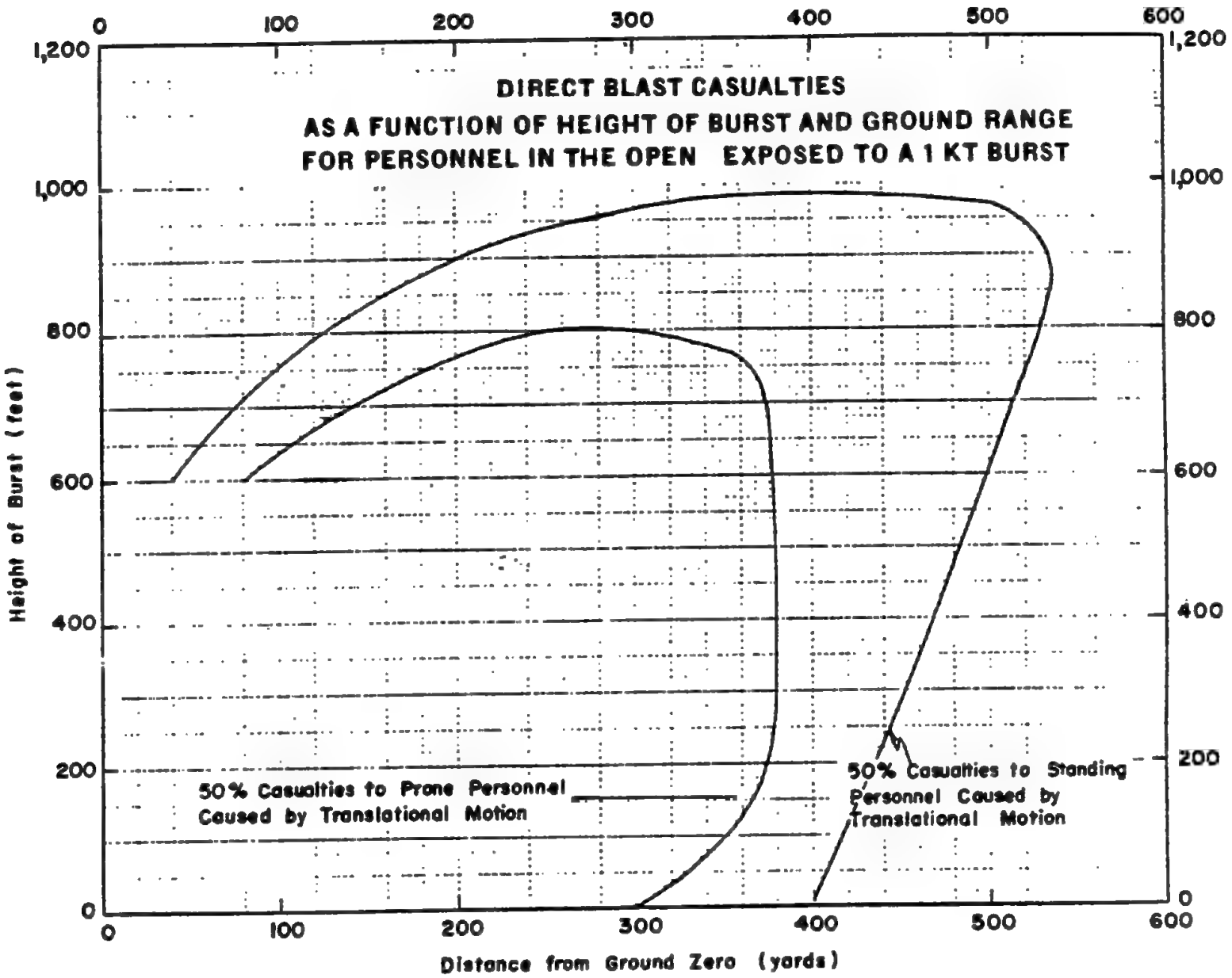

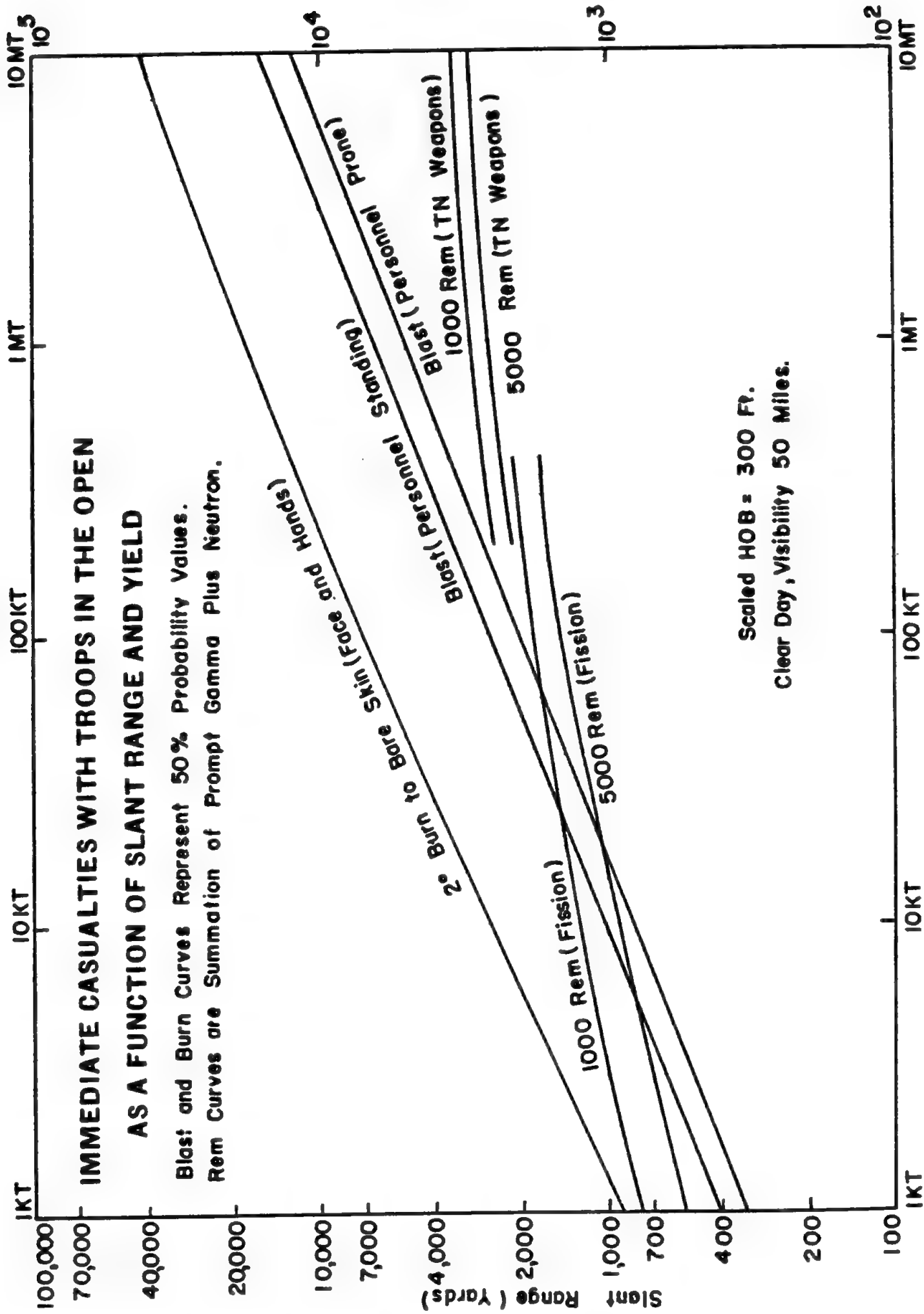

SHIELDING FROM INITIAL AND RESIDUAL GAMMA RADIATION

The curves in figures 6-5 and 6-6 indicate dose transmission factors for bomb initial and residual gamma radiation, respectively, perpendicularly incident upon various thicknesses of earth, water, concrete, iron, and lead. For other materials of known density, the transmission factor may be estimated by interpolation, on a density basis, between the curves given.

Example.

Find: How much concrete would be required to reduce the dose from initial radiation to one one-hundredth the unshielded dose?

Solution: Examine the curve for concrete of figure 6-5. It is seen that the thickness of a slab of concrete required to reduce the dose to 0.01 of its former value is 34 inches. *Answer.*

Reliability. Thicknesses indicated for a given transmission factor are considered reliable within ± 20 percent, for conditions outlined in paragraph 6.5.

Densities of Certain Materials
(Expressed in pounds per cubic foot)

Brick, common.....	120
Clay, dry.....	63
Clay, damp, plastic.....	110

Clay and gravel, dry.....	100
Coal, piled.....	40-50
Earth, dry, loose.....	76
Earth, dry, packed.....	95
Earth, moist, loose.....	78
Earth, moist, packed.....	96
Earth, mud, packed.....	115
Fuel oil.....	54
Granite.....	175
Limestone.....	165
Masonry, stone.....	150
Sand, gravel, dry packed.....	100-120
Fir.....	34
Hemlock.....	29
Oak.....	46
Pine, white.....	26
Pine, yellow.....	40

Related Material.

See paragraph 6.5. For radiation input data, see figures 4-1 through 4-7 for air and surface burst initial gamma. Figures 4-28 through 4-33, neutron induced gamma activity. Figures 4-14 through 4-19, surface burst residual gamma. Figure 4-8, underground burst, initial gamma. Figures 4-20 through 4-23, underground residual gamma. Figure 4-25, harbor burst, residual gamma.

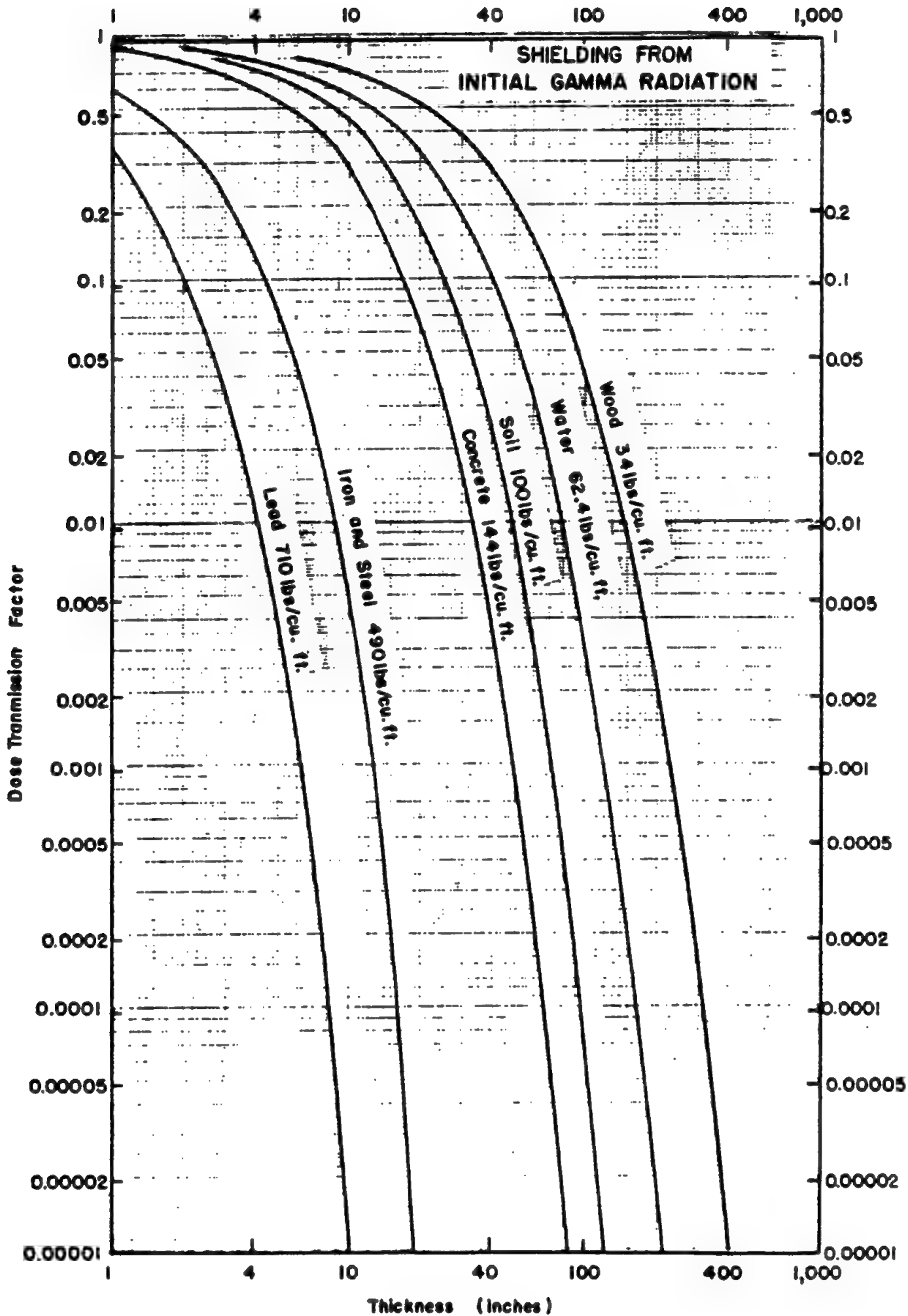
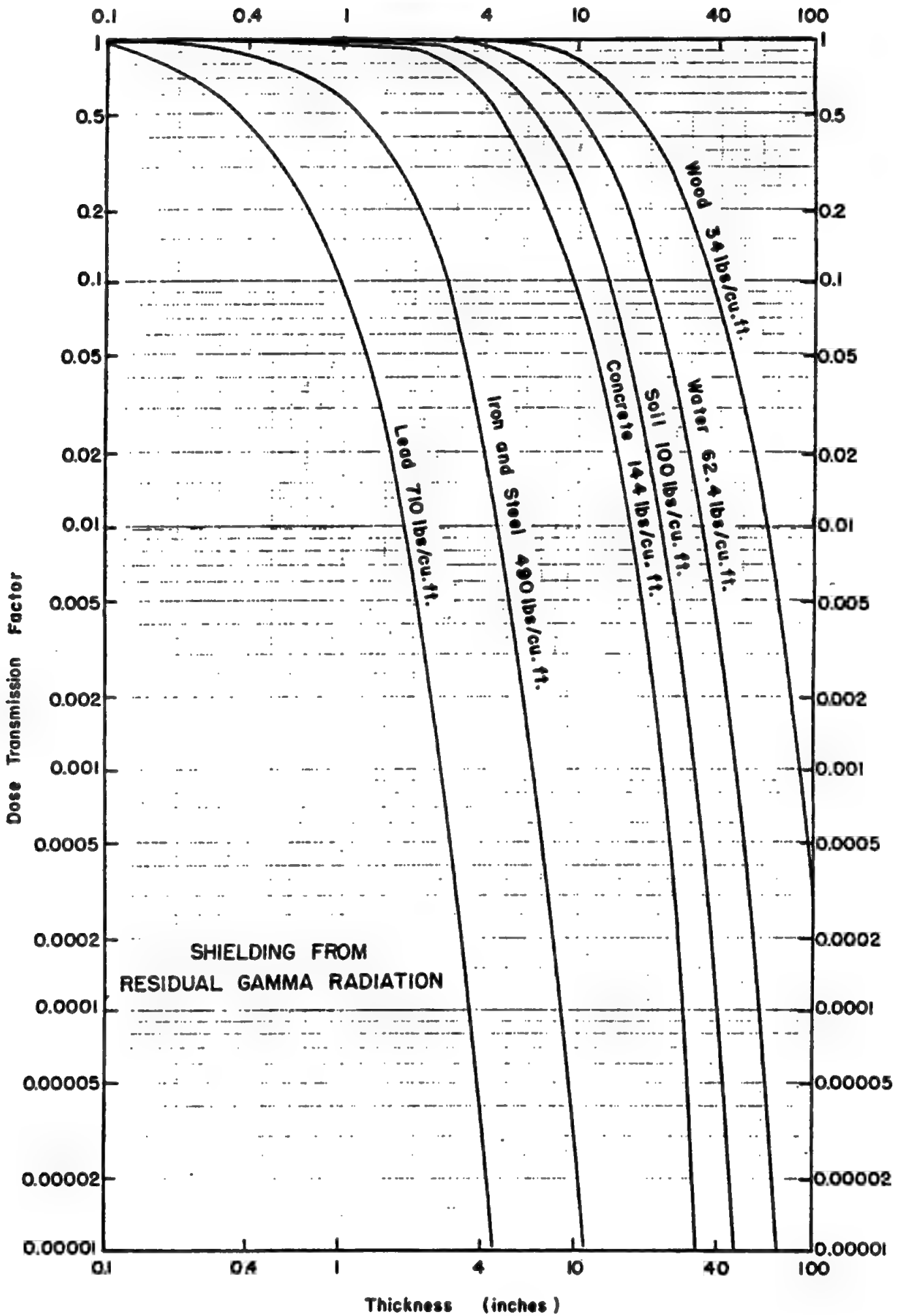

FIGURE 6-6

~~CONFIDENTIAL~~



~~CONFIDENTIAL~~

ately greater. The effect of non-ideal wave forms on air blast loading is described in paragraph 5.2b(1)(f).

- (2) *Loading during the diffraction phase.* An essentially closed large structure with walls that remain intact throughout most of the load duration is primarily sensitive during the diffraction phase, since most of the translational load is applied during this period. As the blast wave strikes this type structure it is reflected, creating overpressures greater than those incident thereon. Subsequently, the reflected overpressure decays to that of the blast wave. As the blast wave progresses, it diffracts around the structure, eventually exerting overpressures on all sides. Before the blast wave reaches the rear face, overpressures on the front exert translational forces in the direction of blast wave propagation. After the blast wave reaches the rear face, the overpressures on the rear tend to counter the overpressures on the front. For smaller structures, the blast wave reaches the rear face more quickly, so that the pressure differential exists for a shorter time. Thus, the net translational loading resulting from overpressures during the diffraction phase depends primarily on structural dimensions. For some structures where wall failure takes place early in the diffraction phase, only the structural frame may remain during the remainder of the diffraction process, and essentially no load is transmitted to the structural frame through the walls. A longer duration blast wave does not materially change the magnitude of the net translational loading during the diffraction phase or the damage resulting therefrom. In other words, the structure is primarily sensitive to the peak blast wave overpressure. Table 7-1 lists those types of structures which are generally affected primarily by blast wave overpressure during the diffraction phase.
- (3) *Loading during the drag phase.* During the diffraction phase, and until the blast wave has passed, dynamic pressures are

also exerted on structures. Dynamic pressure loading is commonly called drag loading. In the case of a closed large structure the drag phase loading is small relative to the overpressure loading during the diffraction phase. For smaller structures, the drag phase assumes greater relative importance. For small area components such as the frame of a structure after removal of siding, the translational load applied as a result of the drag phase is much greater than the net translational loading from overpressures during the diffraction phase. For frame buildings with siding removed during the diffraction phase, the drag phase is the predominant factor in producing further damage. Likewise for bridges, the net load during the diffraction phase is applied for an extremely short time, while the drag phase continues until the entire blast wave passes the structure. Because the drag phase duration is closely related to the duration of the blast wave rather than to the overall dimensions of the structure, damage is dependent not only on peak dynamic pressure but also on the duration of the positive phase of the blast wave. Thus damage to this type of structure is dependent on yield as well as peak loading. Table 7-2 lists those types of structures which are primarily sensitive during the drag phase.

(4) *Damage to structures.*

- (a) *Structural characteristics.* The cases discussed above represent extremes in structural loading. Most structures have characteristics which cause them to be affected by the loading during both the diffraction phase and the drag phase. Some elements of a structure may be damaged more by loading during the diffraction phase; other elements of the same structure may be damaged more by the drag phase. The dimensions and orientation of a structure, together with the number and area of the openings and the rapidity with which wall and roof

about half the dam height is most vulnerable to a surface burst upstream from the dam. An air burst on the downstream side of the dam is the least effective method of producing breaching of concrete gravity dams. Air blast from such a burst or from a burst on top of the dam is a primary damaging agent against powerhouse structures; these should be analyzed according to structural type as in paragraph 7.2.

(2) *Harbor installations.* Air blast is the most important damaging mechanism for most structures around a harbor. Air blast damage to surface structures is discussed in paragraph 7.2. For canal or river locks, where the water level around the gates is low, air blast is effective in making the locks inoperable by damage to the gates.

b. Water Shock. A concrete gravity dam with the reservoir water level higher than about half the dam height is most vulnerable to an underwater burst. As the depth of water increases, the vulnerability of the dam to an underwater burst increases. This is because underwater shock impulse for a given yield weapon at a given distance is greater for greater depths. Only a limited amount of information is available on dam destruction, and scaling laws are not fixed. The following are estimated ranges for damage by a 20 KT underwater burst at mid-depth to full concrete gravity dams (straight or slightly curved in plan):

60 ft. high dam

Cracks are produced at a range of about 300 yards; portions are cracked loose and displaced small distances at a range of about 200 yards.

150-foot high dam

Cracks are produced at a range of about 500 yards; portions are cracked loose and displaced sizable distances at a range of about 200 yards.

500-foot high dam

Cracks are produced at a range of about 1,300 yards; portions are cracked loose and displaced large distances at a range of about 200 yards.

Canal and river locks, where there is a high water level around the gates, are most vulnerable to damage from an underwater burst.

c. Cratering. For earth dams and causeways, the primary damaging mechanism is cratering; for breaching, the dam or causeway should be within the crater. The crater lip formed by an underwater burst in a harbor may create a navigational hazard; however, water erosion may make this hazard temporary. For structures on shore around a harbor, the range for air blast damage is greater than the range of cratering damage to these structures from an underwater burst near the shore. Cratering is the most important damaging mechanism for concrete quay walls and canal and river locks if the structure is within the rupture zone. The crater dimensions formed by an underwater burst can be computed using the procedure given with figures 2-24 through 2-26. Craters from ground surface and underground bursts can be computed from the procedures given in paragraph 2.2. Weapons detonated on the top or at the toe of a concrete gravity dam produce damage to the dam by cratering. The extent of the rupture can be computed by the method given in paragraph 2.2. For a burst on the top of the dam, the extent of rupture determines the amount the water level drops. When the burst is at the toe of the dam the extent of rupture also determines whether the dam loses its stability against overturning. For a detonation in a dam gallery, the extent of damage can be computed as for an underground burst by the method given in paragraph 2.2. Radius of rupture should be taken as 1.5 times the crater depth computed for rock.

d. Water Waves. The many variables involved in predicting damage from wave action require an individual analysis of each target. Among the variables involved are water depth, bottom slope, wave height, wave length, target response characteristics, orientation of target to the wave front, location of target relative to the point of wave breaking, and variation in width of the channel or harbor. Figure 2-34 gives estimated maximum wave height as a function of water depth and burst position. These figures are for a constant depth of water. As the water depth or width of the wave front varies, the wave height also changes. Wave action may cause additional

SEVERE DAMAGE TO M2 OR M4 FLOATING BRIDGES (RANDOM ORIENTATION)
FOR VARIOUS YIELDS AS A FUNCTION OF GROUND RANGE AND HEIGHT OF BURST

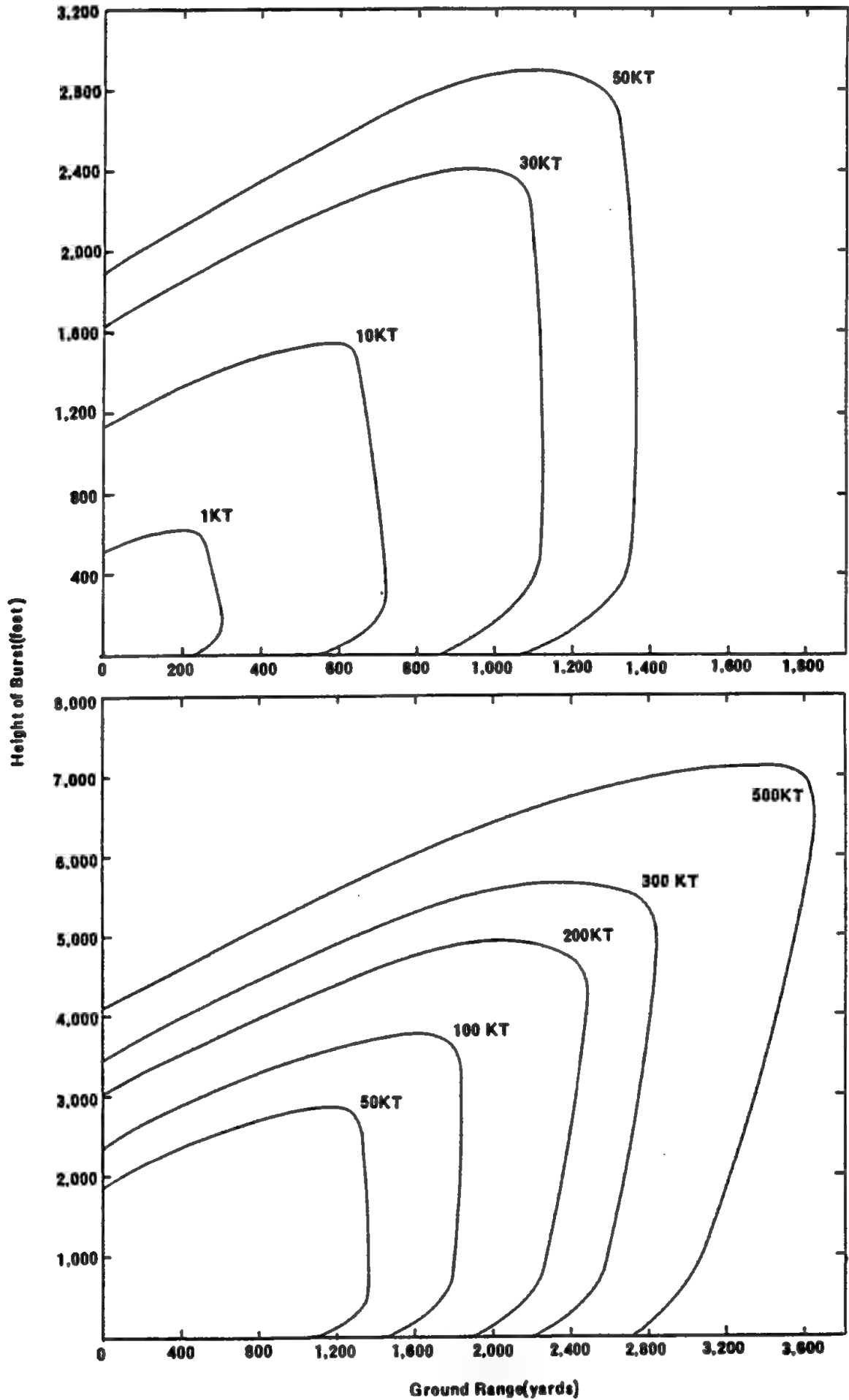

SEVERE DAMAGE TO M2 OR M4 FLOATING BRIDGES (RANDOM ORIENTATION)
FOR VARIOUS YIELDS AS A FUNCTION OF GROUND RANGE AND HEIGHT OF BURST

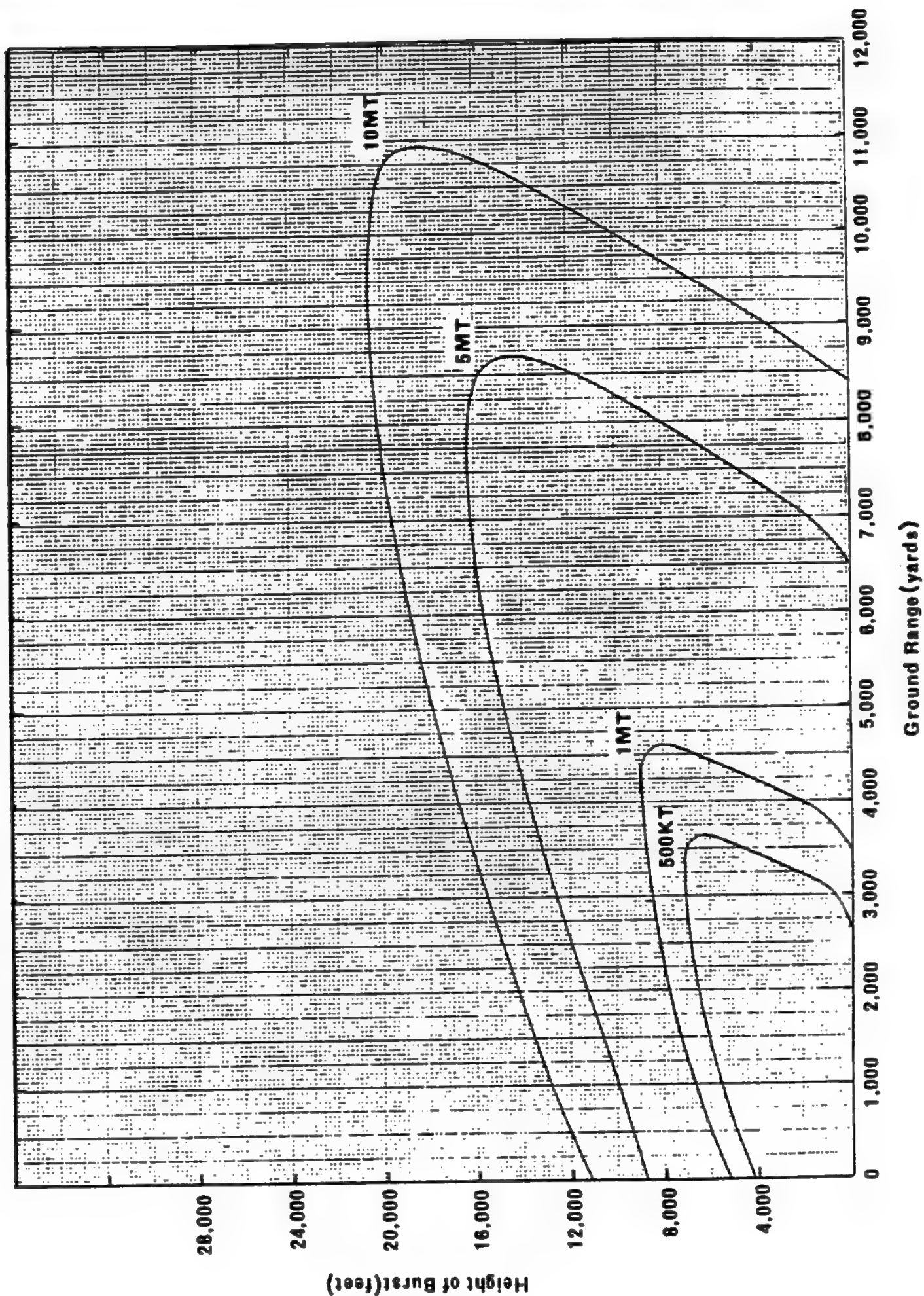

SEVERE DAMAGE TO EARTH COVERED LIGHT STEEL ARCH SHELTER
(10 GAUGE CORRUGATED STEEL WITH 20 TO 25 FOOT SPAN)
BY VARIOUS YIELDS AS A FUNCTION OF HEIGHT OF BURST AND GROUND RANGE

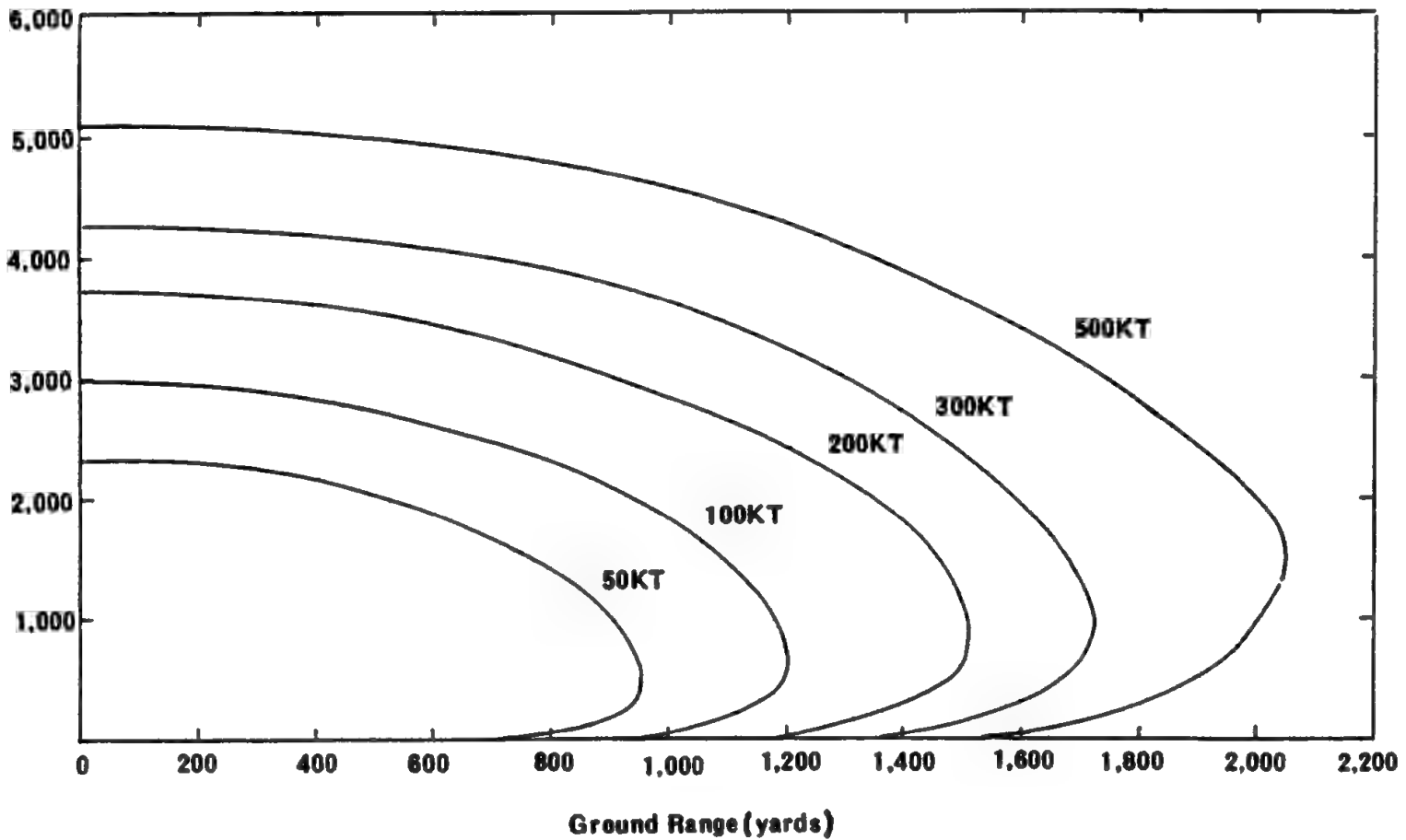
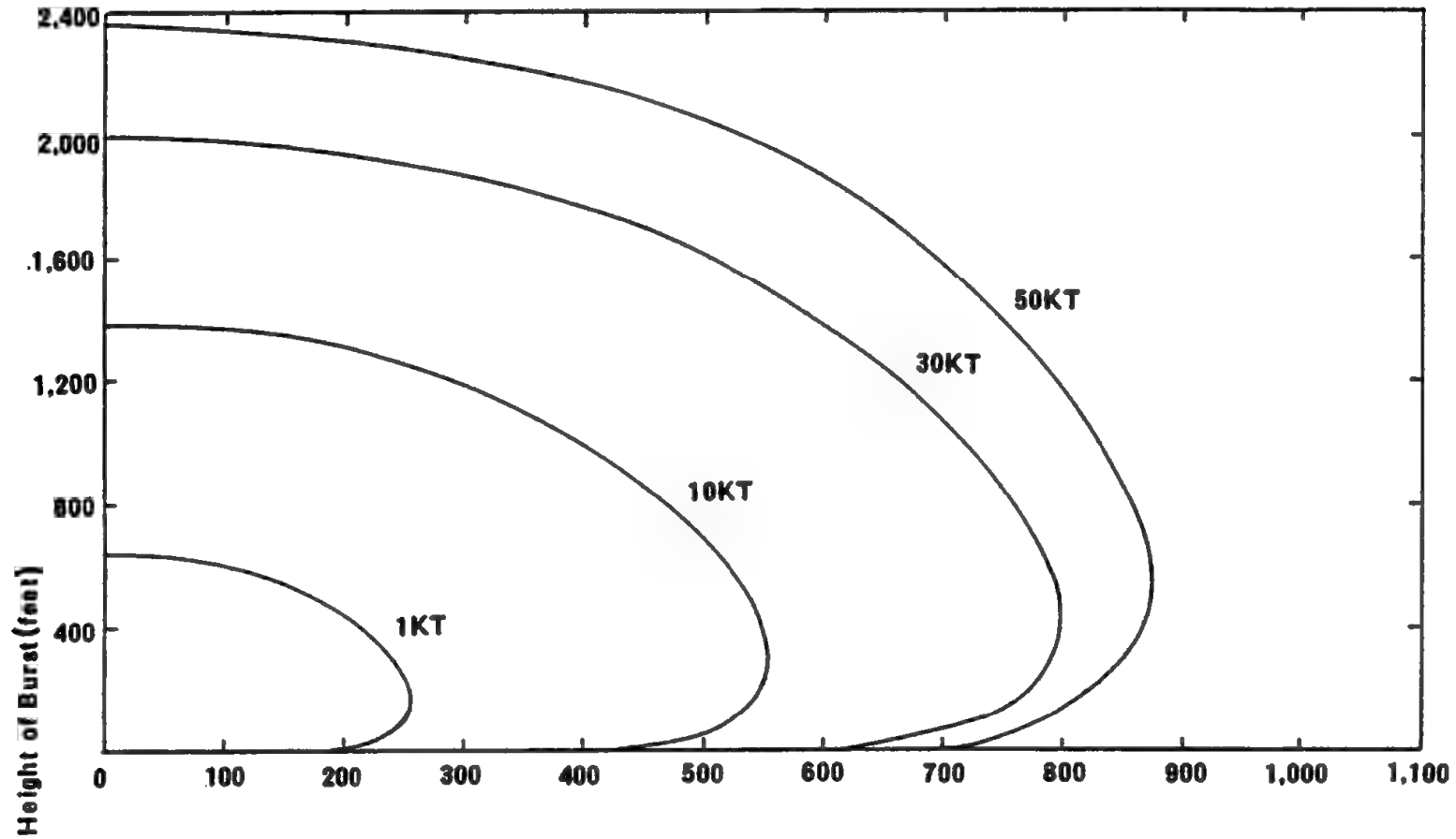

**SEVERE DAMAGE TO EARTH COVERED LIGHT STEEL ARCH SHELTER
(10 GAUGE CORRUGATED STEEL WITH 20 TO 25 FOOT SPAN)
BY VARIOUS YIELDS AS A FUNCTION OF HEIGHT OF BURST AND GROUND RANGE**

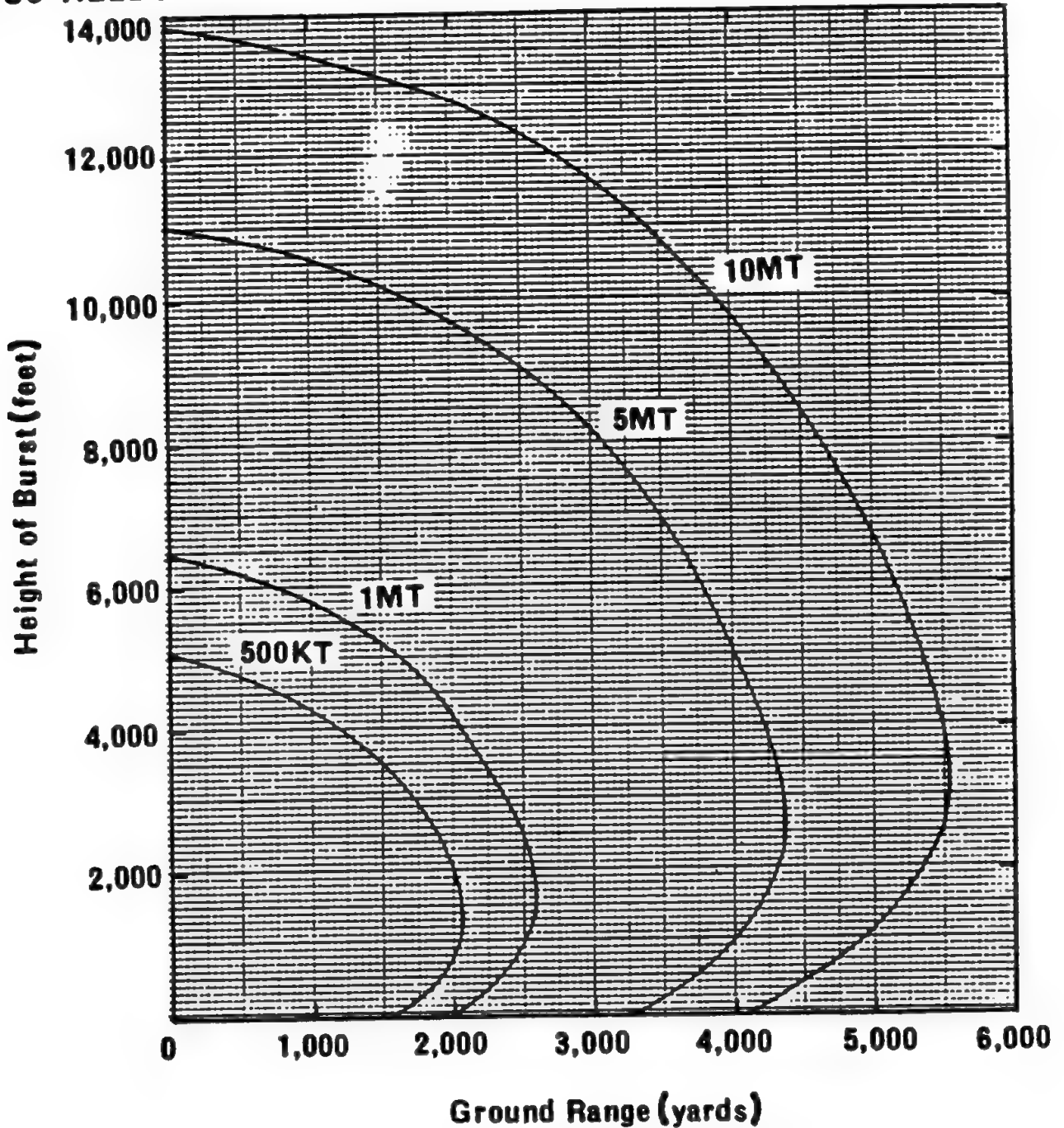

DAMAGE TO FIELD FORTIFICATIONS

Figures 7-20 through 7-22 are a series of plots of height of burst vs. scaled ground range for 50 percent probability of severe, moderate, or light damage to various field fortifications in Nevada type soil scaled to 1 KT. To determine 90 percent or 10 percent probability of damage to structures, lines of probability should be drawn between the indicated 50 percent probability lines. For example, because there is little difference between a line indicating approximately 10 percent probability of severe damage and one indicating 90 percent probability of moderate damage, a single line can represent both and should be drawn midway between the indicated lines for 50 percent probability of severe and moderate damage. To determine the range for 90 percent probability of severe damage use one-half the yield at the same burst height.

The curves in figure 7-22 are based on results of tests run in a *consolidated dry sand and gravel soil*. Trenches and foxholes in damp soil with stable vegetation or dry silty soil will receive moderate and severe damage at ranges less than those shown in figure 7-22. The curves of figure 7-22 are for average rectangular foxholes with the longitudinal axis perpendicular to the direction of air blast propagation. Damage will be equal or less for other orientations.

Scaling. To obtain heights of burst and distances for yields other than 1 KT, use the scaling procedure—

$$\frac{d_1}{d_2} = \frac{h_1}{h_2} = \frac{W_1^{1/3}}{W_2^{1/3}}$$

where d_1 and h_1 are ground distance and height of burst for yield W_1 KT, and d_2 and h_2 are the corresponding ground distance and height of burst for yield W_2 KT.

Example.

Given: A 50 KT burst at an altitude of 1,000 feet.

Find: To what horizontal distance there is a 50 percent probability of severe damage to an unrevetted foxhole in a dry, consolidated sand and gravel soil.

Solution:

$$h_1 = \frac{h_2 \times W_1^{1/3}}{W_2^{1/3}} = \frac{1,000 \times 1}{(50)^{1/3}} = 270 \text{ feet,}$$

the corresponding burst height for 1 KT. From figure 7-22 the ground range for severe damage is 185 yards. To obtain the corresponding ground range for 50 KT:

$$d_2 = \frac{d_1 \times W_2^{1/3}}{W_1^{1/3}} = \frac{185 \times (50)^{1/3}}{1} = 680 \text{ yards.}$$

Answer.

Reliability. This figure is based on results of a limited number of full scale tests at which severe, moderate and light damage were observed.

Related material.

See paragraph 7.4.

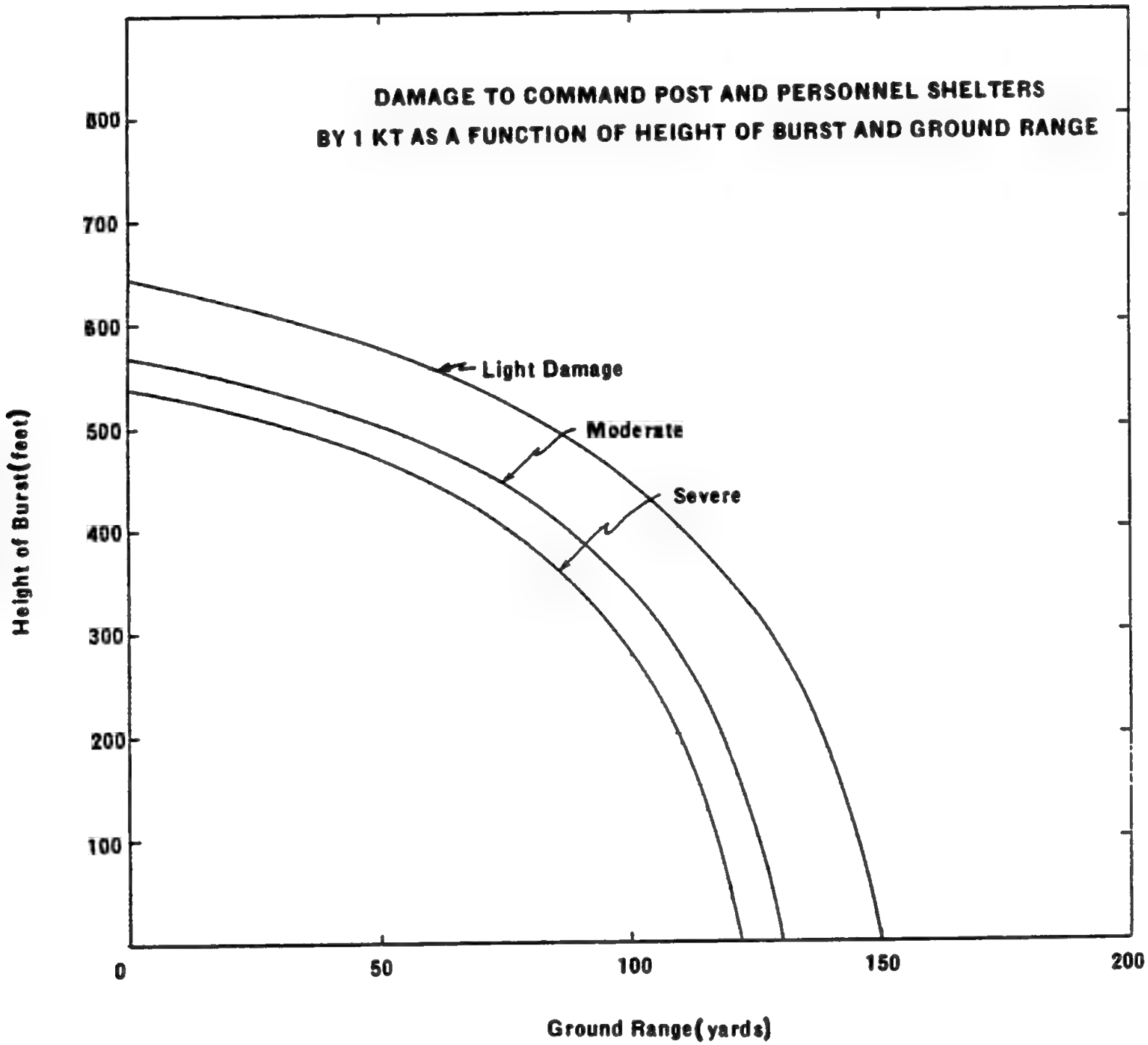

DAMAGE TO MACHINE GUN EMPACEMENTS
BY 1 KT AS A FUNCTION OF HEIGHT OF BURST AND GROUND RANGE

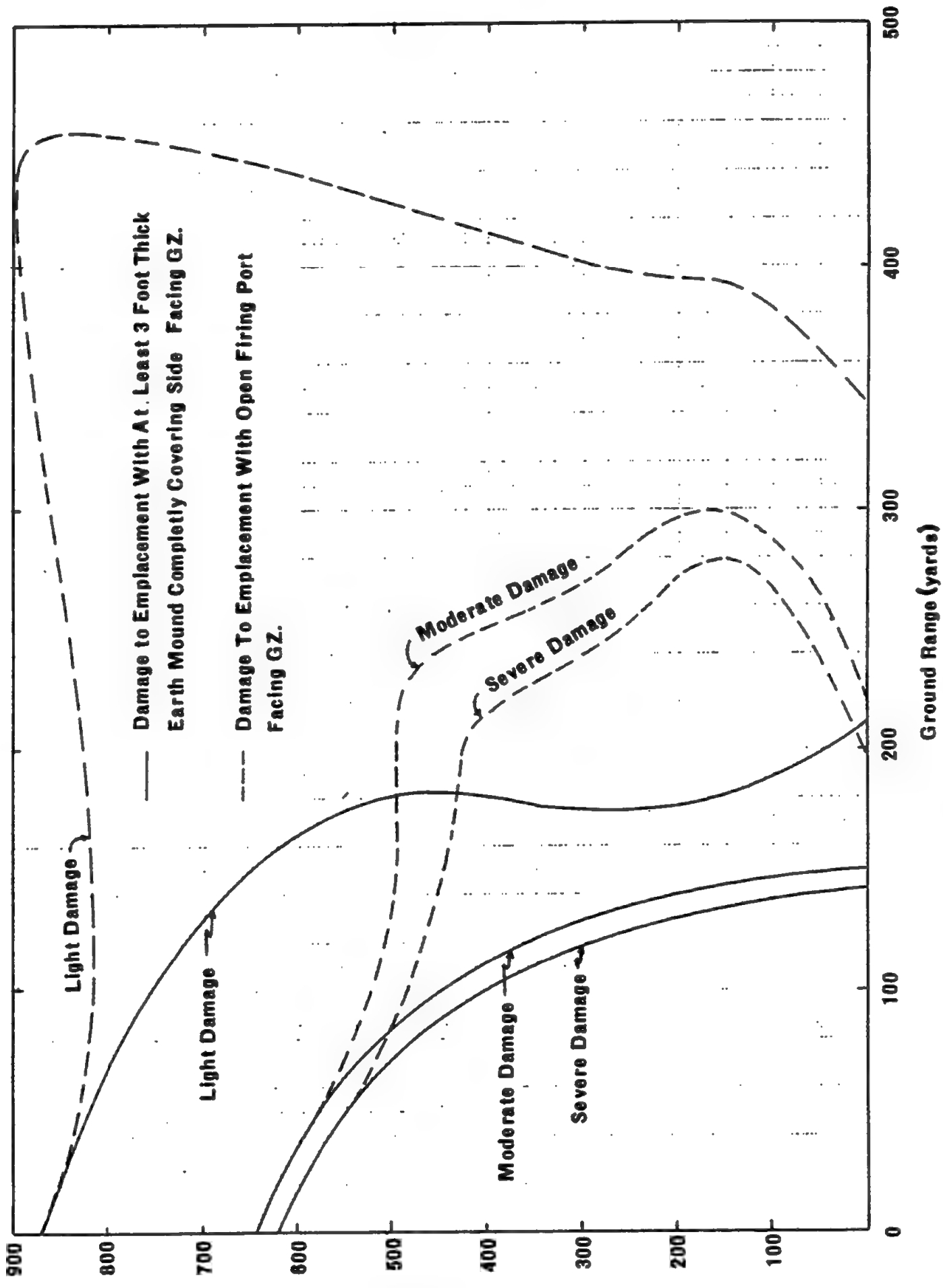

Height of Burst (feet)

Ground Range (yards)

PAGE 7-55 WITHHELD IN ITS ENTIRETY

SECTION VIII

DAMAGE TO NAVAL EQUIPMENT

8.1 General

a. Damage Mechanisms. Mechanical damage to surface ships may be caused by air blast, water shock, and surface wave action. Submerged submarines may be damaged by water shock. Thermal damage to naval vessels and topside equipment is not considered a significant factor, in that it does not of itself cause sinking or immobilization.

b. Damage Classification for Surface Ships. The degree of damage to surface ships and surfaced submarines is separated into three categories—

- (1) *Severe damage (probable sinking).* The ship is sunk or is damaged to an extent requiring rebuilding.
- (2) *Moderate damage (immobilization).* The ship requires extensive repairs. This includes damage to certain shock sensitive components or their foundations, such as propulsion machinery, boilers, and damage to interior equipment.
- (3) *Light damage.* This category includes damage to electronic, electrical, and mechanical equipment; however, the ship may still be able to operate effectively.

c. Damage Classification for Submarines. For submerged submarines two degrees of damage are specified—

- (1) *Lethal hull damage.* Pressure hull rupture occurs.
- (2) *Interior shock damage (surfacing damage).* Extensive interior damage to equipment, machinery, and piping occurs with immobilization probable. Submarines are forced to surface.

8.2 Surface Ship Damage

a. Water Shock Damage. Water shock is the principal cause of damage to surface ships from underwater explosions. The directly transmitted shock, however, is not the sole damaging mechanism. When the water depth is of the order of

3,000 feet or less for a 1 KT underwater burst, it is possible that the shock wave reflected from the bottom may produce more severe equipment damage at a given range than the direct shock wave, even though the peak pressure of the reflected wave is less. This phenomenon results from the reflected wave propagating in a more vertical direction and hence being more effective in producing vertical velocities in the hull. In addition, certain bottom formations may focus the reflected wave, resulting in local areas of much higher pressures. It is therefore not possible to predict accurately the effects in a given case without extensive knowledge of the bottom structure in the vicinity of the detonation. To estimate the effects of the reflected shock wave in the absence of such knowledge, it is necessary to assume the bottom to be flat and a perfect reflector, and to use the image of the actual burst point as the apparent source of the reflected shock wave.

Refraction of the water shock wave, discussed in paragraph 2.3a(4), may act to reduce the range at which a given level of damage occurs. This reduction is not significant, however, except at the ranges for light damage, and the actual magnitude of the reduction depends upon the individual circumstances. Since this range reduction is of a small magnitude when considering severe and moderate damage levels and is in the conservative direction when considering possible effects against weapon delivery vessels, the influence of water shock wave refraction has not been included in the damage curves.

Water shock damage curves for surface ships are presented in figures 8-1 through 8-3. These curves are based upon several criteria. Severe damage to ships with multi-plate side protective systems (cruisers, carriers, etc.) is defined by bottom deflection, while for those with thin skin shells (transports, destroyers, etc.), it is defined by side deflection. Moderate and light damage to all types is related to the bottom plate velocity.

b. *Air Blast Damage.* As the depth of a burst is decreased, a transition from water shock to air blast as the primary damage-producing mechanism occurs. Peak overpressure is considered a satisfactory parameter for estimating damage to ships from air blast. Peak overpressures of 5 psi cause light damage to most types of surface ships, while overpressures required for severe damage vary from 25 psi for destroyers to 45 psi for battleships. Figures 8-1 and 8-2 present damage ranges for a 1 KT detonation for heights of burst less than 600 feet and depths of burst less than 800 feet, with means of scaling to other yields. A tabulation of peak overpressure required to cause ship damage is given in table 8-1 for use with burst heights greater than those shown in figures 8-1 and 8-2. For such burst heights, distances to which overpressures extend can be obtained from figure 2-17.

Table 8-1. Surface Ship Peak Air Overpressure Damage Criteria

Type of ship	Peak air overpressure (psi)		
	Severe	Moderate	Light
Aircraft carriers.....	30	20	5
Battleships.....	45	25	5
Cruisers (heavy).....	40	20	5
Cruisers (light) (AA).....	30	20	5
Destroyers.....	25	15	5
Pontoons (for pier construction).....	60	-----	-----
Transports.....	30	20	5
LST's, landing craft and landing vehicles.....	25	15	5
Submarines (surfaced).....	80	60	-----

c. *Water Wave Damage.* Water waves are a contributing factor in causing damage to surface ships. Wave action may add to the damage to a ship which has already been weakened by air and water shock. The waves may also cause "hogging" damage to ships oriented end-on to the burst, and may cause ships oriented beam-on to the burst to capsize. Small craft may be overturned and sunk or destroyed by wave action.

d. *Thermal Damage.* Thermal damage to naval vessels and topside equipment is probably limited to superficial scorching of exposed organic surfaces

(including paint). Fires are unlikely to originate aboard vessels as the result of thermal radiation from a nuclear explosion, except in cases where severe and probably overriding damage due to blast is also sustained.

8.3 Subsurface Target Damage

a. Submarines.

(1) *Air blast damage.* Air blast damage to surfaced submarines is significant only for the case of surface, transition zone or air bursts. Peak air overpressures of 80 and 60 psi are expected to cause severe and moderate damage, respectively, to surfaced submarines.

(2) *Water shock damage.* Water shock is the controlling damage-producing mechanism for a submerged submarine for any burst position, and also for a surfaced submarine subjected to an underwater burst. The criterion used for estimating lethal hull damage is a function of "excess impulse." This excess impulse is defined as the impulse delivered by that portion of the shock overpressure which is in excess of the static collapse pressure minus the hydrostatic pressure. In deep water when a sharp change in water temperature with depth exists (thermocline) and the weapon is fired in close proximity to this region, refraction may reduce the range for a given degree of damage on the order of perhaps 20 percent. This reduction will only occur when the weapon and the submarine are on opposite sides of the thermocline. For weapons fired well below or above the thermocline, there should be no reduction. Isodamage curves for the hull lethal range and interior shock damage range are presented in figures 8-4 and 8-5 for a submarine with a 600 psi static collapse pressure subjected to a 10 KT and a 30 KT surface or underwater detonation, with methods for scaling to other yields. No account of refraction has been taken in the damage curves presented. Non-linear effects as described in paragraph 2.3 have been incorporated. Initial translational

velocity is the criterion used for prediction of shock damage to submarine equipment.

b. *Underwater Mines.* Underwater mines are expected to be neutralized when the peak pressure acting on the mines is equal to or greater than the mine case static collapse pressure, or when the

mines are within the crater. Figures 8-6 through 8-8 show the neutralization ranges for mines with hydrostatic collapse pressures of 250, 500, and 1,000 psi in depths of water of 50, 100, and 200 feet and for a range of yields from 1 to 100 KT. These curves are computed for mines and burst both on the bottom.

SURFACE SHIP DAMAGE

Figure 8-1 gives estimated ranges for severe damage (probable sinking) plotted as a function of burst height and depth for surface ships for a 1 KT detonation. Figure 8-2 gives the ranges for moderate (immobilization) damage and for light damage as functions of burst height and shallow depths. Figure 8-3 is an extended plot of light damage vs. depth of burst. This latter figure enables an estimate to be made for the effect of the bottom reflection pressures on the predicted light damage range using the assumptions given in paragraph 8.2a (i. e., a flat perfect reflector bottom and a burst depth at the image of the actual burst point). For evaluation of light damage, a value should be found for both the direct shock wave and the bottom reflected shock wave and the larger value chosen.

Scaling. For yields other than 1 KT the following relations can be used to estimate ranges for a given degree of damage:

$$\frac{d_1}{d_2} = \frac{W_1^{1/3}}{W_2^{1/3}} = \frac{h_1}{h_2},$$

where d_1 = range for a given degree of damage for yield W_1 KT at a depth h_1 , and d_2 = range for a given degree of damage for yield W_2 KT at depth h_2 .

Example.

Given: A 30 KT burst at a depth of 2,000 feet in 5,000 feet of water.

Find:

- The range at which an aircraft carrier suffers severe damage.
- The range at which a destroyer suffers light damage.

Solution:

- The depth of 2,000 feet for a 30 KT burst corresponds for a 1 KT to

$$\frac{h_1}{h_2} = \frac{W_1^{1/3}}{W_2^{1/3}} \text{ or } h_1 = \frac{h_2 \times (W_1^{1/3})}{W_2^{1/3}}$$

$$h_1 = \frac{2,000(1)}{(30)^{1/3}} = \frac{2,000}{(30)^{1/3}} = 640 \text{ feet.}$$

From figure 8-1 the range at which an aircraft carrier suffers severe damage from a 1 KT burst 640 feet below the surface is 320 yards.

The range of severe damage to an aircraft carrier for a 30 KT detonation at a depth of 2,000 feet is then

$$\frac{d_1}{d_2} = \frac{W_1^{1/3}}{W_2^{1/3}} \text{ or } d_2 = \frac{(d_1) \times (W_2)^{1/3}}{W_1^{1/3}} = \frac{(320) \times (30)^{1/3}}{1} = 1,000 \text{ yards. Answer.}$$

- From either figure 8-2 or 8-3 the range at which a destroyer suffers light damage from the direct shock wave of a 1 KT burst at 640 feet below the surface is 990 yards.

The imaginary burst point from which the bottom reflected shock waves are assumed to come is equal to the depth of the water plus the height of the weapon above the bottom, or $5,000 + 3,000 = 8,000$ feet for the 30 KT weapon. The corresponding depth for a 1 KT is

$$\frac{h_1}{h_2} = \frac{W_1^{1/3}}{W_2^{1/3}} \text{ or } h_1 = \frac{h_2 \times W_1^{1/3}}{W_2^{1/3}},$$

$$h_1 = \frac{8,000 \times (1)}{(30)^{1/3}} = \frac{8,000}{(30)^{1/3}} = 2,560 \text{ ft.}$$

From figure 8-3 the range at which a destroyer suffers light damage from the shock wave of a 1 KT burst at 2,560 feet is 1,300 yards. Since this is greater than the range noted above (990 yards), the bottom reflected shock wave governs. Hence the range of light damage to a destroyer from a 30 KT burst at a depth of 2,000 feet in 5,000 feet of water is then,

$$\frac{d_1}{d_2} = \frac{W_1^{1/3}}{W_2^{1/3}} \text{ or } d_2 = \frac{(d_1) \times (W_2)^{1/3}}{W_1^{1/3}} = \frac{(1,300) \times (30)^{1/3}}{1} = 4,000 \text{ yards. Answer.}$$

Reliability. Based on limited data. Predictions become less reliable as depth of burst decreases.

Related Material.

See paragraphs 8.1 and 8.2.

See also figures 8-4 and 8-5 for submarine damage.

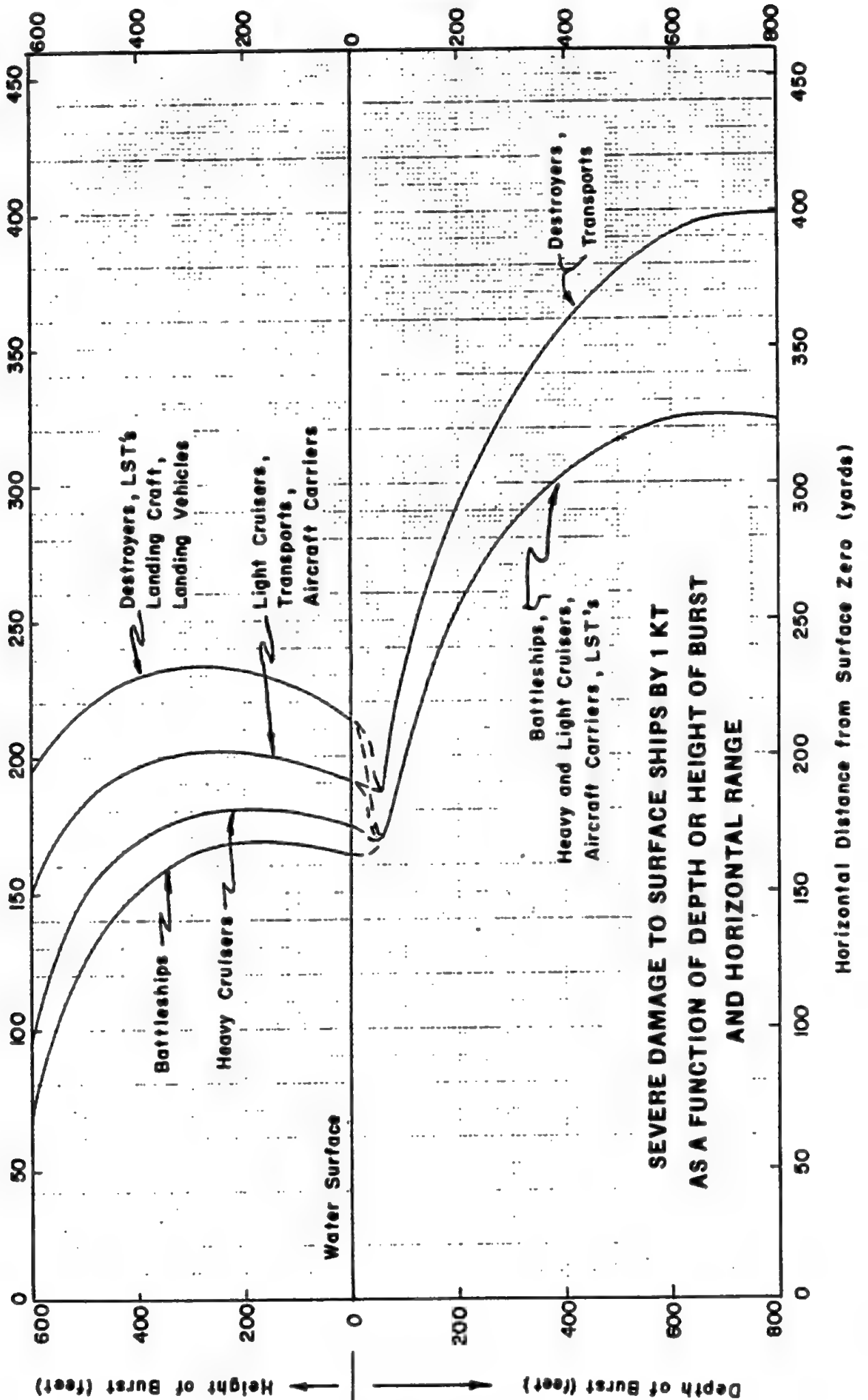

CONFIDENTIAL

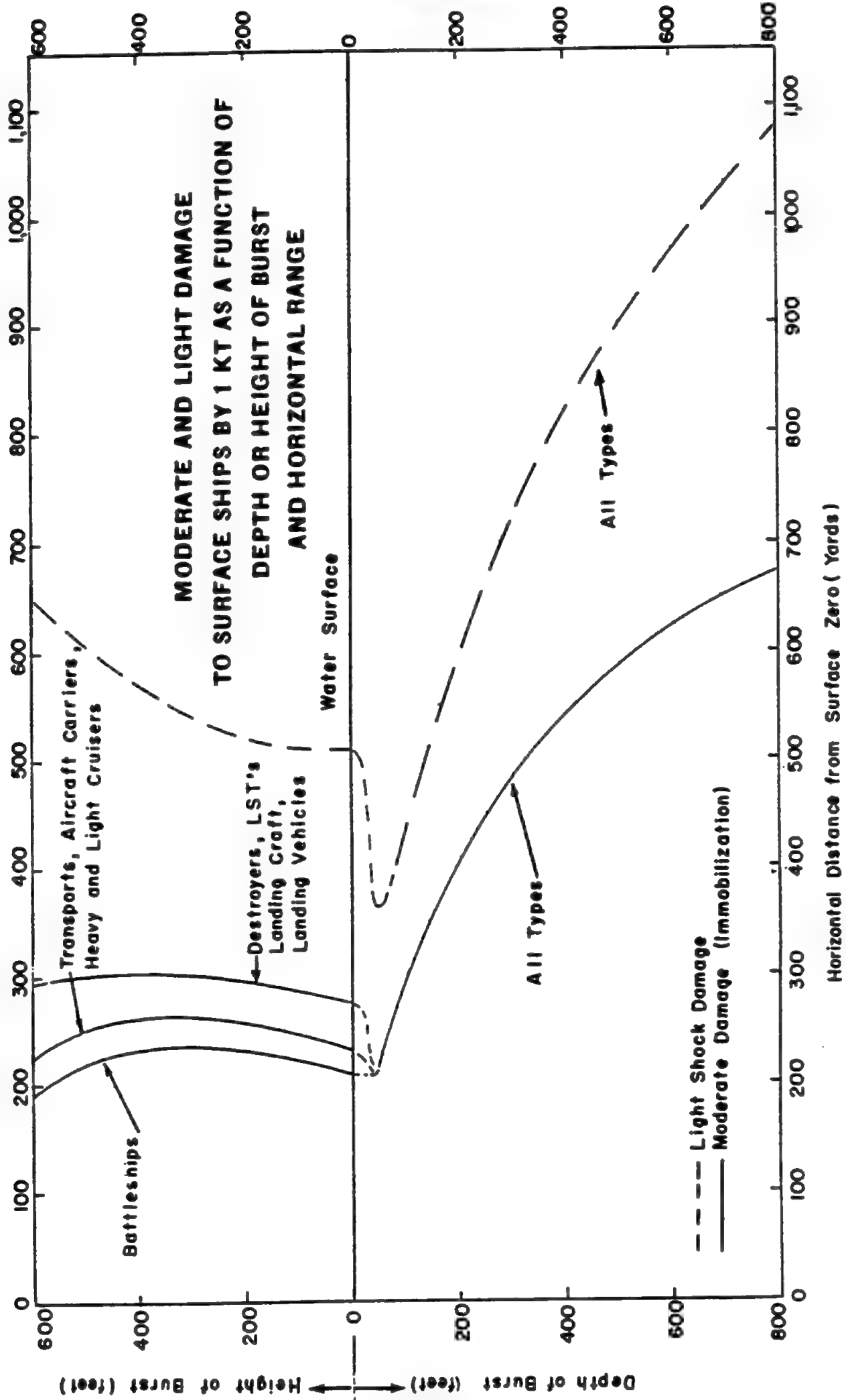

CONFIDENTIAL

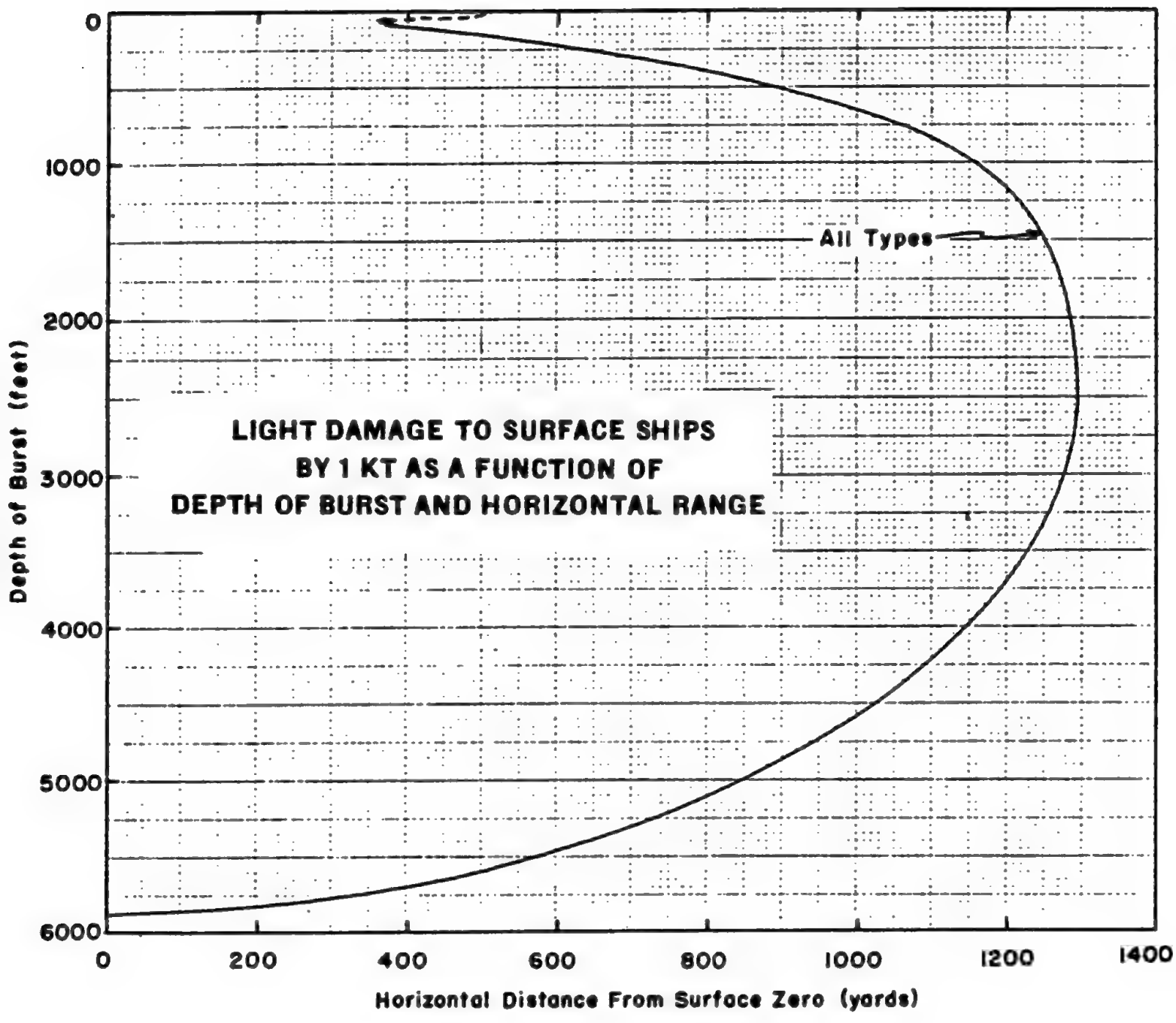

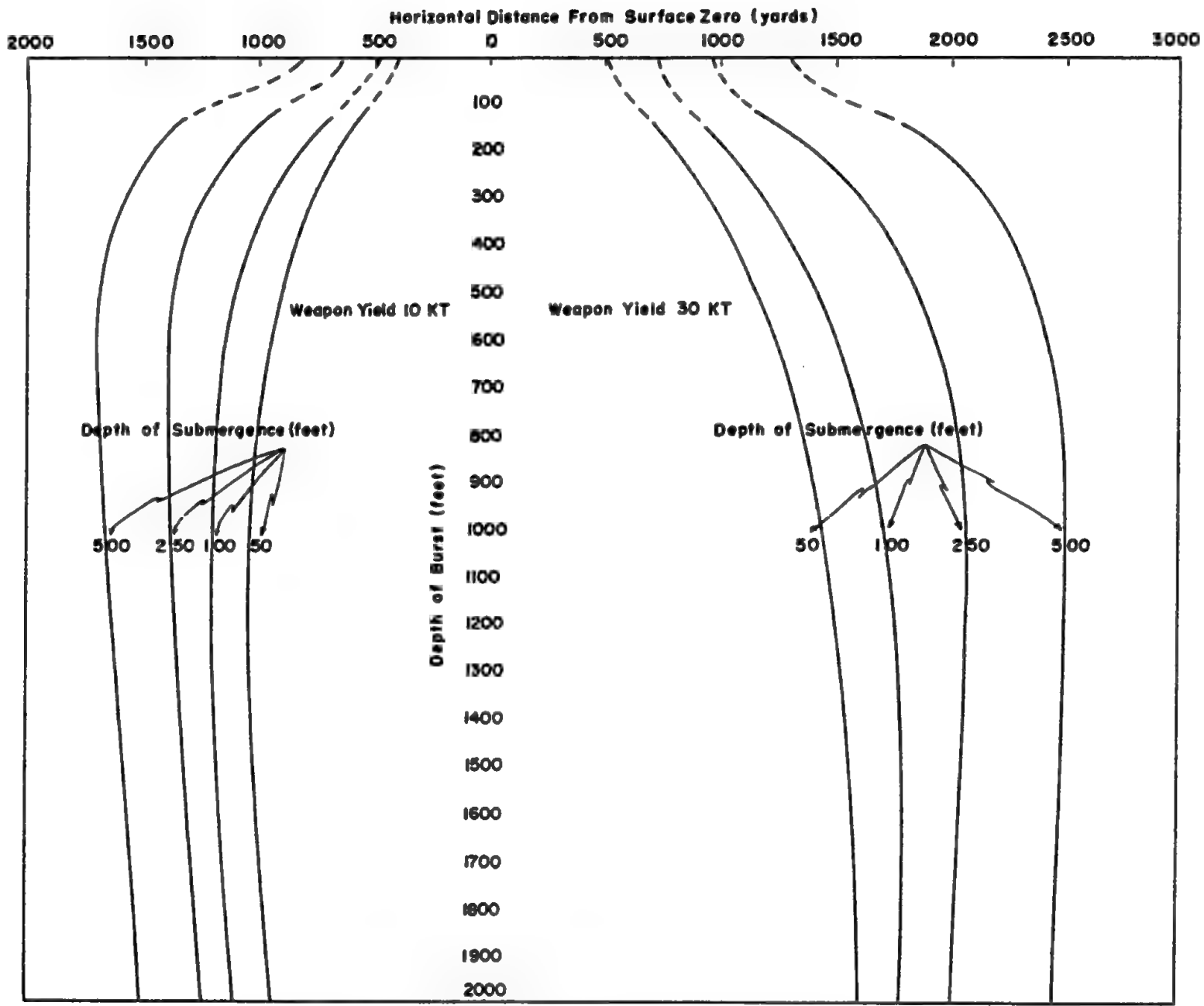

**SUBMARINE LETHAL HULL DAMAGE BY 10KT AND 30KT
AS A FUNCTION OF DEPTH OF BURST AND HORIZONTAL RANGE**

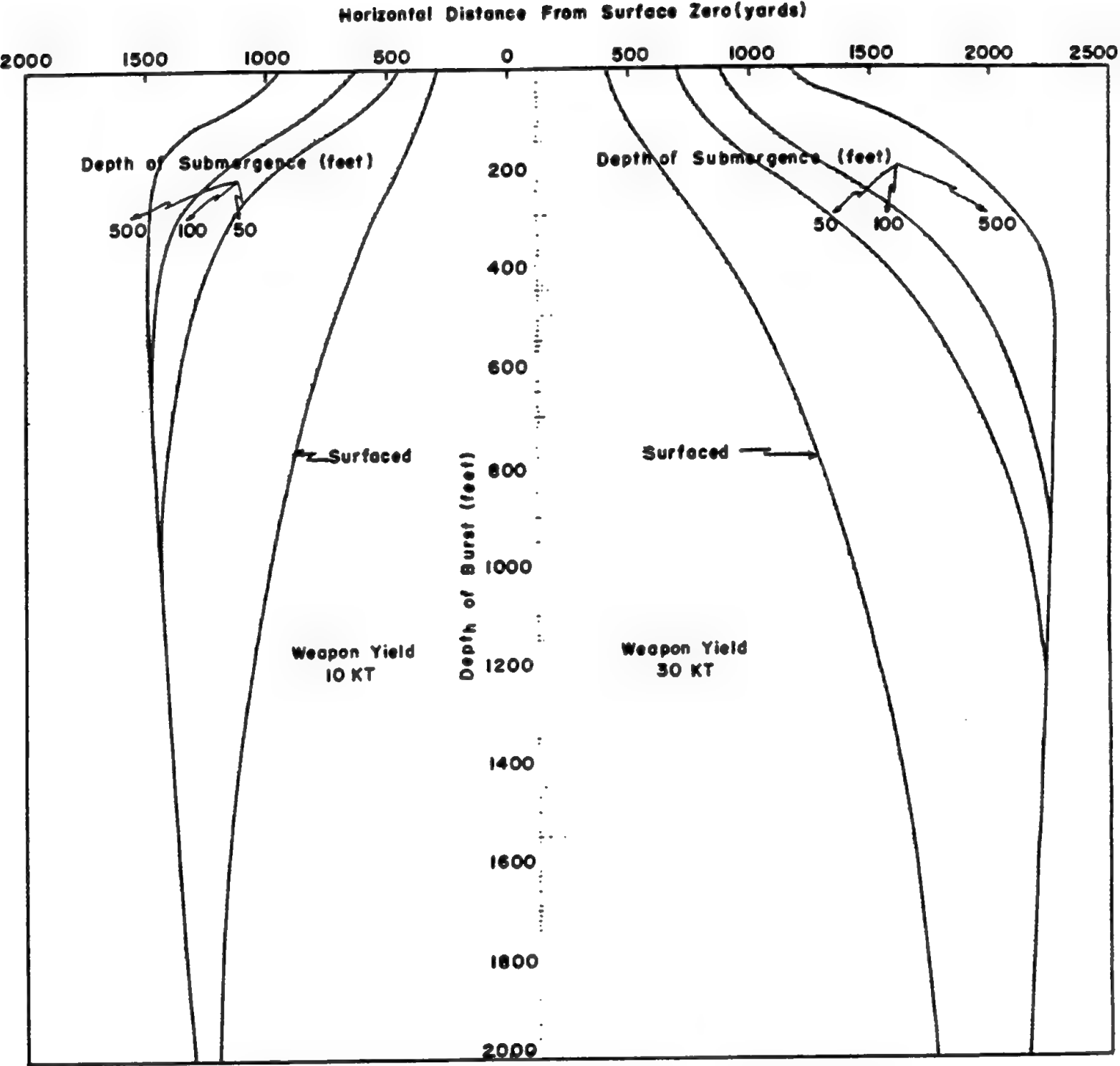

**SUBMARINE INTERIOR SHOCK DAMAGE BY 10 KT AND 30 KT
AS A FUNCTION OF DEPTH OF BURST AND HORIZONTAL RANGE**

UNDERWATER MINEFIELD NEUTRALIZATION

Figures 8-6 through 8-8 give ranges for underwater minefield neutralization as a function of yield for collapse pressures of 250, 500 and 1,000 psi with both the burst and mines on the bottom. Figure 8-6 is for a 50-foot water depth, figure 8-7 for 100 feet, and figure 8-8 for 200 feet. Linear interpolation between these curves can be used for intermediate water depths and mine case static collapse pressures.

Example.

Given: A 30 KT burst on the bottom in 100 feet of water.

Find The range at which mines with a 500 psi static case collapse pressure located on the bottom are neutralized.

Solution: The range at which the mines are neutralized is taken directly from figure 8-7 to be 400 yards. *Answer.*

Reliability. Based on limited data.

Related Material.

See paragraph 8.3b.

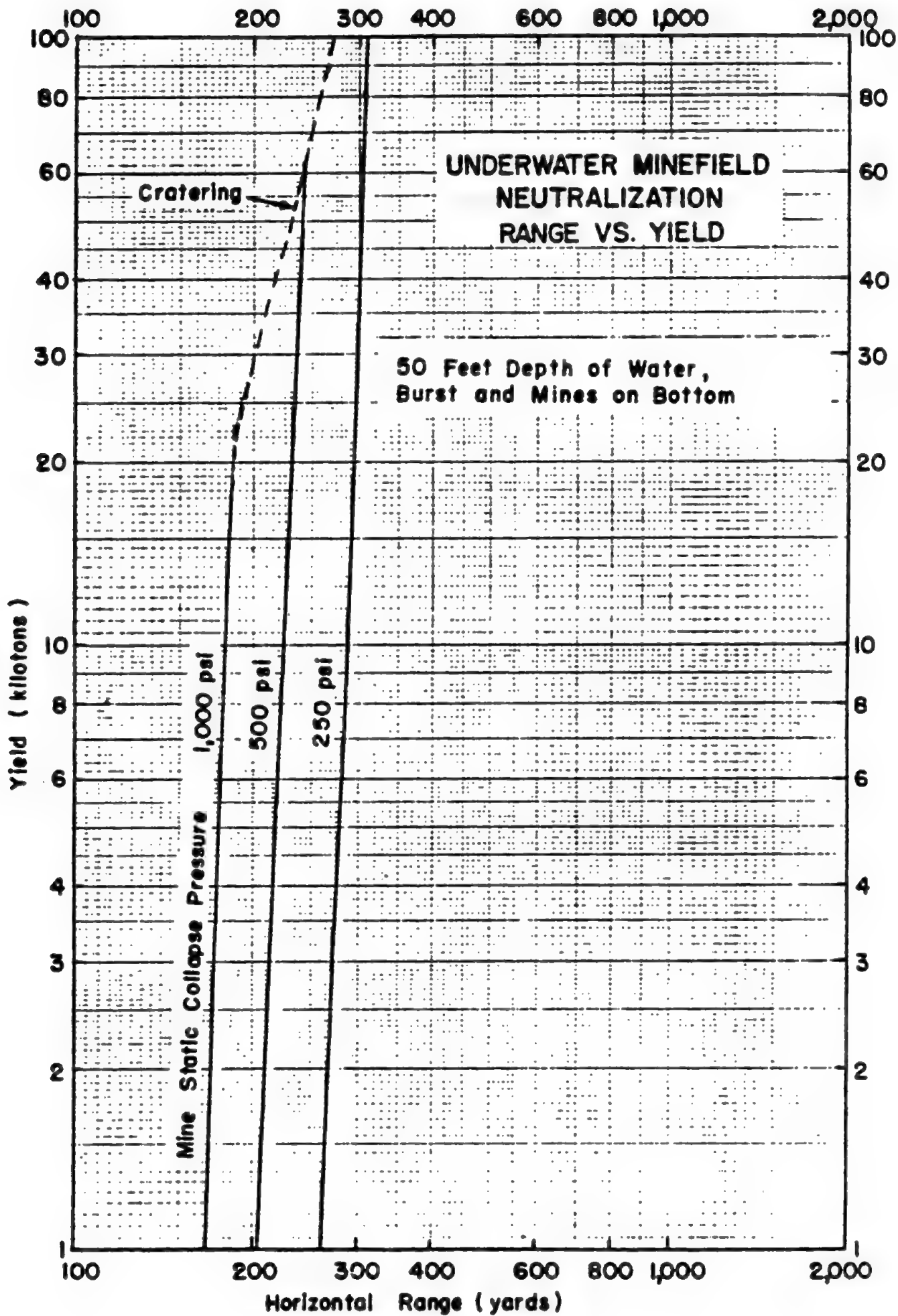

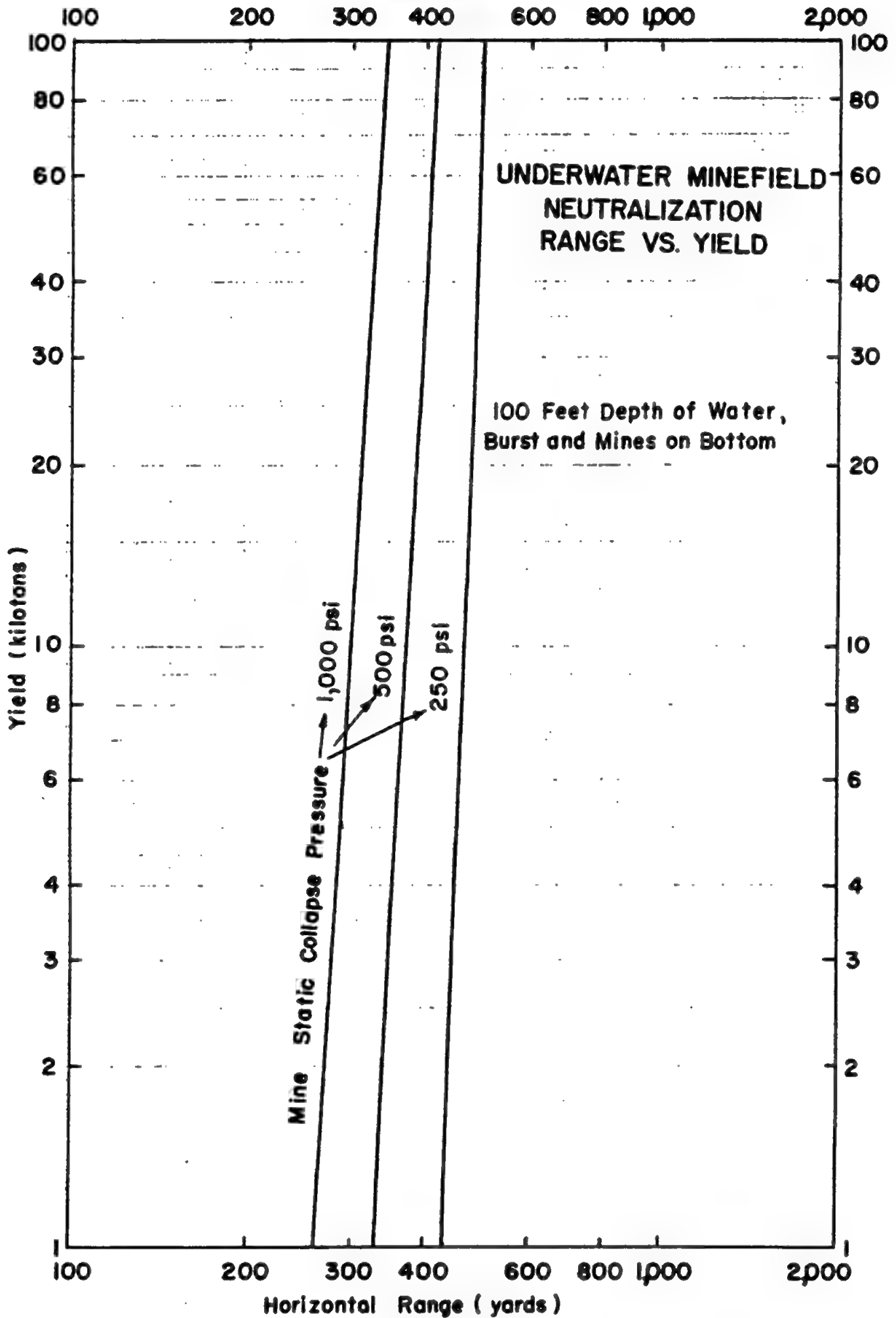

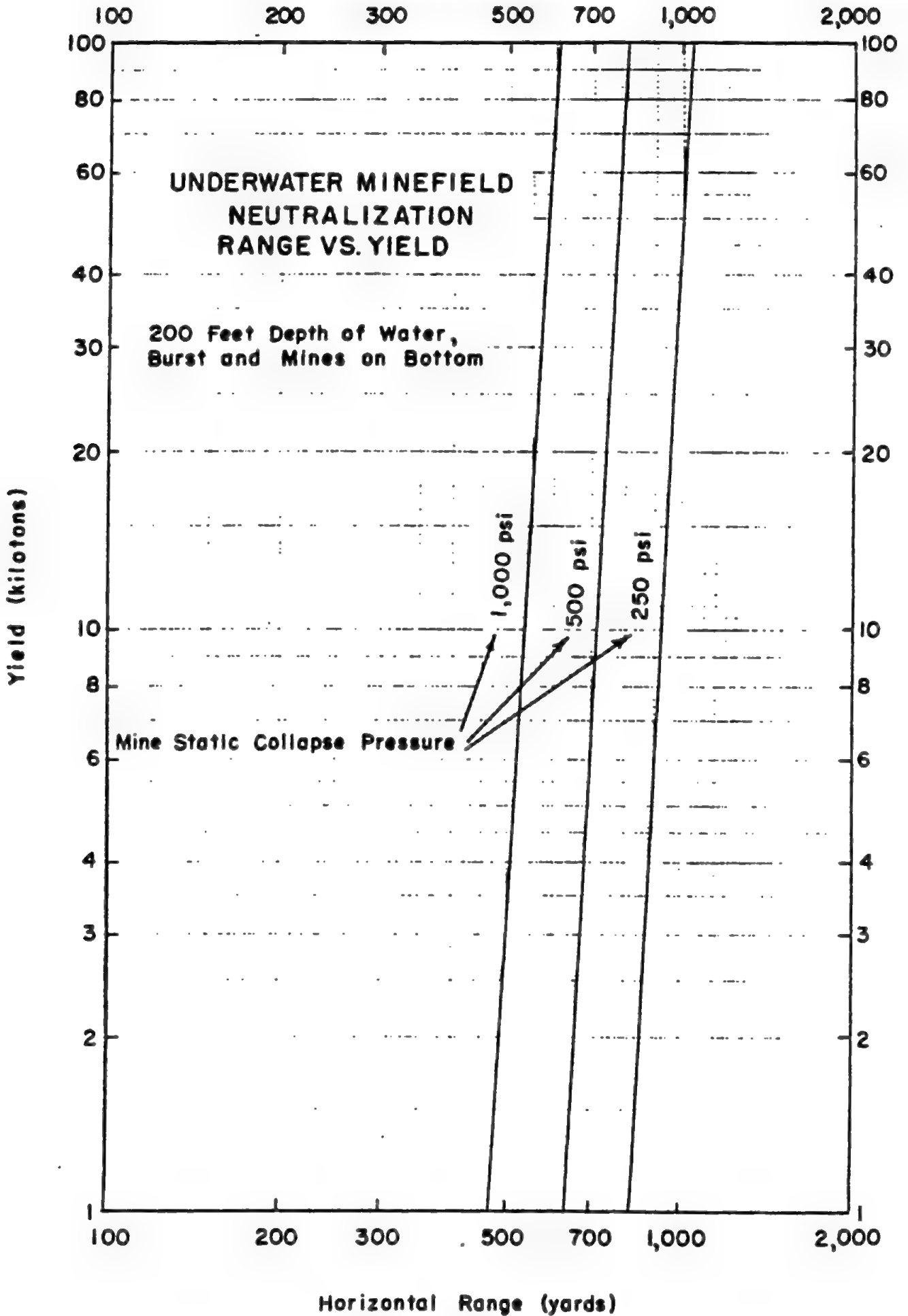

SECTION IX

DAMAGE TO AIRCRAFT

9.1 General

Aircraft are relatively vulnerable to the blast and thermal effects of nuclear detonations. Since aircraft are designed within narrow limits for flight and landing loads, the structure can withstand only small additional loads imposed by weapon effects. Blast overpressure on striking an aircraft surface may cause dishing of panels and buckling of stiffeners and stringers. On the side struck by the blast wave, the pressure is increased above the incident intensity by reflection and a diffractive force of short duration is generated. As the wings, empennage, and fuselage are completely enveloped by the blast, further dishing and buckling of skins and structure may result from the crushing effect of the differential pressure between the outside and inside of the aircraft components. Additional damaging loads are also developed by the particle velocity accompanying the blast wave. This particle velocity results in drag loading, which is usually termed "gust loading" with reference to aircraft. The duration of the gust loading is many times that of the diffractive loading, and it develops bending, shear, and torsion stresses in the airfoil and fuselage structures. For aircraft in flight, these stresses are usually the major effect on the aircraft.

The weapon thermal energy which is absorbed by aircraft components can also produce damaging effects. Very thin skins are rapidly heated to damaging temperatures by exposure to the short period thermal flux, because the energy is absorbed by the skin so much more rapidly than it can be dissipated by conduction and convective cooling. Exposed fabric, rubber, and similar materials with low ignition and charring temperatures are vulnerable items which may also initiate extensive fire damage at very low levels of radiant exposure. In recent years, designers of military aircraft have reduced aircraft vulnerability to thermal effects by coating thin skinned materials with

low absorptivity paints, by eliminating ignitable materials from exposed surfaces, and by substitution of thicker skins for very thin skins. With these protective measures and design modifications, aircraft can be safely exposed at radiant exposure levels several times those which formerly caused serious damage.

9.2 Parked Aircraft

a. Air Blast. The diffraction phase loading and the drag phase loading have varying relative importance in producing damage to parked aircraft. In general, the diffraction phase is of primary importance in the zones of light and moderate damage. In the zone of severe damage the drag phase assumes more importance. Orientation of the aircraft with respect to the point of burst affects vulnerability considerably. With the nose of the aircraft directed toward the burst, higher weapon effects inputs can be absorbed without damage than for any other orientation. The longer duration of the positive phase of the blast from a large yield weapon may result in some increase in damage over that expected from small yields at the same overpressure level. This increase is likely to be significant at input levels producing severe damage but is not likely to be important at the levels of moderate and light damage. Experiments have shown that revetments provide only slight shielding against blast overpressure and under some conditions reflected pressures within the revetment are higher than corresponding incident pressures. Revetments do provide significant shielding from damage due to flying debris borne by the blast wave. Damage to various types of parked aircraft may be estimated from the curves of figures 9-1, 9-2 and 9-3. Distances to which a given level of damage from a subsurface burst occurs may be derived from figure 7-18 in conjunction with these figures. Quantitative data with respect to high yield influence on damage is not

available. Therefore this influence has not been reflected in the damage curves.

b. Thermal Radiation. A military weapon delivery aircraft properly prepared for its delivery mission with reflective paint and all vulnerable materials shielded from direct thermal radiation will not be damaged by thermal inputs at distances where damage from blast inputs is severe. Other aircraft not so prepared may sustain serious damage at very low thermal levels as a result of ignition of items such as fabric covered control surfaces, rubber and fabric seals, cushions and headrest covers. The radiant exposure levels at which damage to these materials may be expected can be estimated from the data of table 12-2. Aircraft painted with dark paint are especially vulnerable to thermal radiation damage because the dark painted surfaces absorb three to four times the thermal energy that is absorbed by polished aluminum surfaces or surfaces protected with reflective paint. Temporary emergency shielding as provided by trees, buildings, embankments, or similar barriers may be useful for thermal protection of unprepared aircraft, but any of these may increase the blast damage by adding to the flying debris or by multiple reflection of incident overpressures.

9.3 Aircraft in Flight

a. Air Blast. The response of an in-flight aircraft to blast loading is very complex. Factors which influence the response are—

- (1) Velocity and altitude of the aircraft.
- (2) Orientation of the aircraft with respect to the burst.
- (3) Intensity and duration of the overpressure and particle velocity accompanying the blast wave.
- (4) Geometry of the aircraft components.
- (5) Natural frequency of the aircraft structural components.
- (6) Weight and weight distribution at the time of shock arrival.

For weapon delivery aircraft, analytical methods have been developed for predicting response under a variety of flight conditions and for kiloton and megaton yields. These methods require a detailed analysis for each aircraft type. Such analyses have been verified for

several aircraft types by observing response at weapon effects tests.

For prediction of weapon effects required to destroy an enemy aircraft in flight, the response problem becomes even more complex. The knowledge of structural behavior and load carrying capacity of aircraft structures in regions above design limit, through ultimate strength to failure, is very limited. Estimates of lethal envelopes for various types of aircraft have been made on the basis of approximate analysis and limited experimental data. Three of these typical envelopes are presented in figure 9-4 to illustrate the general shape and size of regions about a nuclear antiaircraft burst within which an enemy aircraft may be expected to be destroyed by the weapon blast.

b. Thermal Radiation. The radiant exposure of an aircraft in flight varies widely with atmospheric conditions, orientation of the aircraft with respect to the burst, the ground reflecting surfaces, and clouds. Scatter and reflection add to the direct radiation and under some circumstances the thermal energy incident on an aircraft in space may be two to three times that computed at a given slant range from figure 3-6. Conversely, when a heavy cloud layer is between the burst and the aircraft the radiant exposure may be only a fraction of the predicted value for a given range. In other situations, reflected radiation from clouds may contribute significant thermal energy to areas of the aircraft shaded from direct radiation. During weapon effects tests of an aircraft flying in a cloud above the burst, the radiant exposure at the top of the aircraft and its cockpit area was observed to be as much as one-fourth of the direct radiation on the lower surfaces. This experiment demonstrated the need for protection of weapon delivery aircraft from radiant exposure from any direction. For subsonic weapon delivery aircraft which are adequately protected from thermal radiation, the blast loading is usually the limiting effect. However, supersonic aircraft can outrun the shock wave from a delivered weapon, so that thermal inputs determine the minimum safe separation distance of the aircraft and detonation.

DAMAGE TO NON-COMBAT AIRCRAFT

Figure 9-1 presents height of burst vs. ground range curves for light, moderate and severe damage to randomly oriented parked transport airplanes, light liaison airplanes, and helicopters. These curves are drawn for 1 KT and are based on the following definitions of damage and corresponding peak overpressure criteria:

Light Damage--That damage which does not prevent flight of the aircraft, though performance may be restricted thereby. Transport airplanes, 1 psi; light liaison airplanes, $\frac{1}{2}$ psi; helicopters, $\frac{1}{2}$ psi.

Moderate Damage--That damage which requires field maintenance to restore the aircraft to operational status. Transport airplanes, 2 psi; light liaison airplanes, 1 psi; helicopters, $1\frac{1}{2}$ psi.

Severe Damage--That damage which requires depot level maintenance to restore the aircraft to operational status. Transport airplanes, 3 psi; light liaison airplanes, 2 psi; helicopters, 3 psi.

Scaling. Height of burst and ground range for a given degree of damage scale as the cube root of the yield:

$$\frac{h_1}{h_2} = \frac{d_1}{d_2} = \frac{W_1^{1/3}}{W_2^{1/3}}$$

where h_1 and d_1 are height of burst and ground distance for yield W_1 , and h_2 and d_2 are the corresponding height of burst and distance for yield W_2 .

Example.

Given: A 100 KT weapon is to be burst at optimum height to obtain moderate damage to parked transport airplanes.

Find: The ground range at which moderate damage may be expected and the optimum height of burst.

Solution: From figure 9-1, the optimum height of burst for 1 KT is 1,300 feet. The optimum height of burst for 100 KT is $(100)^{1/3} \times 1300 = 6,000$ feet. *Answer.*

Also from figure 9-1, the ground range for moderate damage from a 1 KT burst at a height of burst of 1,300 feet is 1,380 yards. The corresponding ground range for 100 KT is $(100)^{1/3} \times 1,380 = 6,400$ yards. *Answer.*

Reliability. These curves are based on full scale test data for military bomber and fighter aircraft and detailed analysis of weapons effects on basic structural components. It is considered that they represent the best available estimates, for the aircraft types specified, of distances at which 50 percent of the aircraft parked at that range may be expected to be damaged to the degree specified.

Related Material.

See paragraph 9.2.

See also figures 9-2 and 9-3.

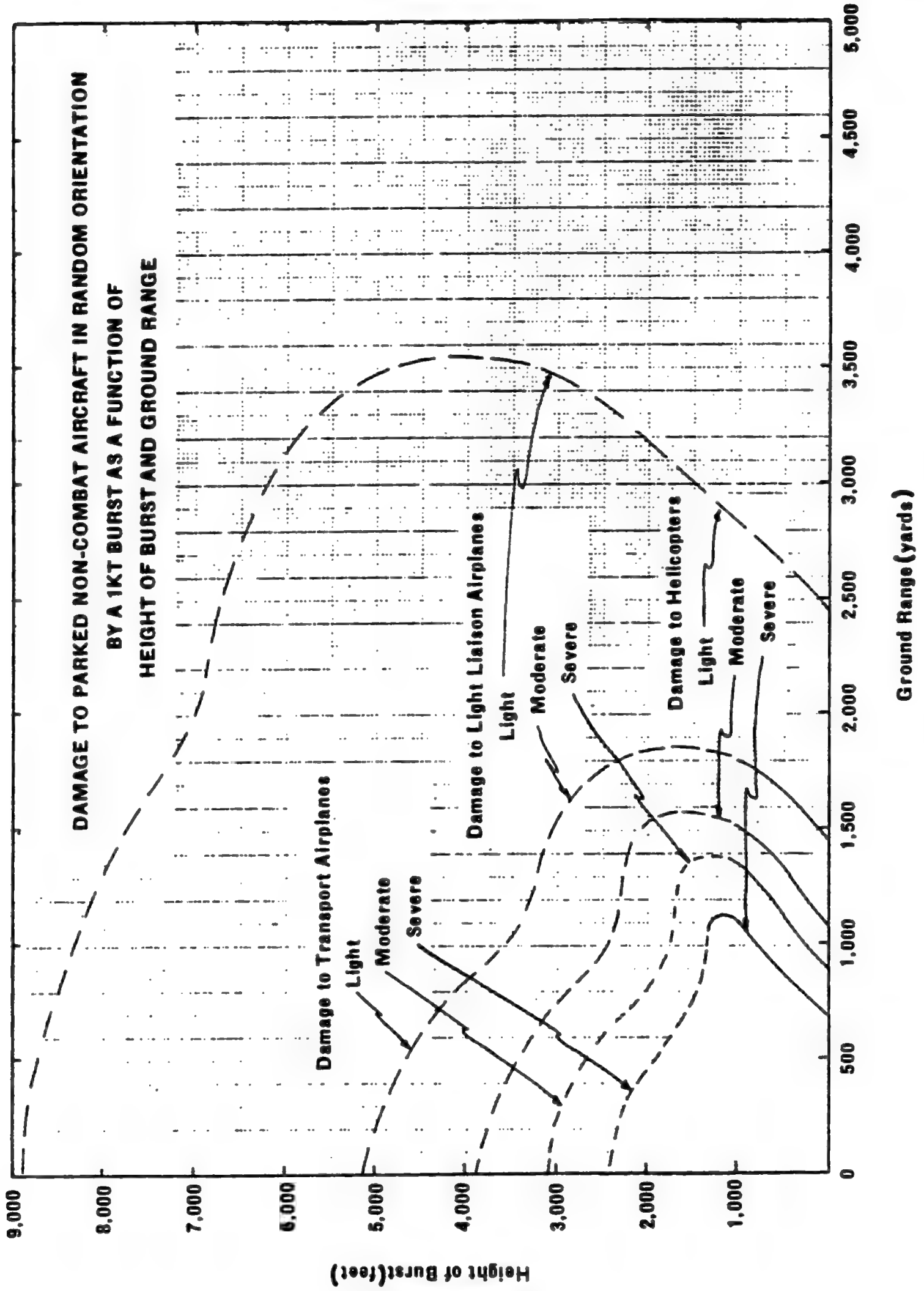

DAMAGE TO PARKED COMBAT AIRCRAFT, RANDOM ORIENTATION

Figure 9-2 presents height of burst vs. ground range curves for light, moderate and severe damage to bomber and fighter aircraft for random orientation. These curves are drawn for 1 KT and are based on the following definitions of damage and corresponding peak overpressure criteria.

Light Damage—That damage which does not prevent flight of the aircraft, though performance may be restricted thereby. Jet bombers, 1½ psi; propeller fighters, 2 psi; jet fighters, 2 psi.

Moderate Damage—That damage which requires field maintenance to restore the aircraft to operational status. Jet bombers, 2½ psi; propeller fighters, 4 psi; jet fighters, 5 psi.

Severe Damage—That damage which requires depot level maintenance to restore the aircraft to operational status. Jet bombers, 4 psi; propeller fighters, 5 psi; jet fighters, 8 psi.

Scaling. Height of burst and ground range for a given degree of damage scale as the cube root of the yield:

$$\frac{h_1}{h_2} = \frac{d_1}{d_2} = \frac{W_1^{1/3}}{W_2^{1/3}}$$

where h_1 and d_1 are height of burst and ground distance for yield W_1 , and h_2 and d_2 are the cor-

responding height of burst and distance for yield W_2 .

Example.

Given: A 50 KT burst at ground level.

Find: At what range from ground zero must a jet fighter be parked in order to be no more than lightly damaged.

Solution: From figure 9-2, the distance from ground zero for light damage to jet fighters for a 1 KT burst is 900 yards. The corresponding distance for a 50 KT burst is $900 \times (50)^{1/3} = 3,300$ yards. *Answer.*

Reliability. These curves are based on full scale test data for military bomber and fighter aircraft and detailed analysis of weapons effects on basic structural components. It is considered that they represent the best available estimates, for the aircraft types specified, of distances at which 50 percent of the aircraft parked at that range may be expected to be damaged to the degree specified.

Related Material.

See paragraph 9.2.

See also figures 9-1 and 9-3.

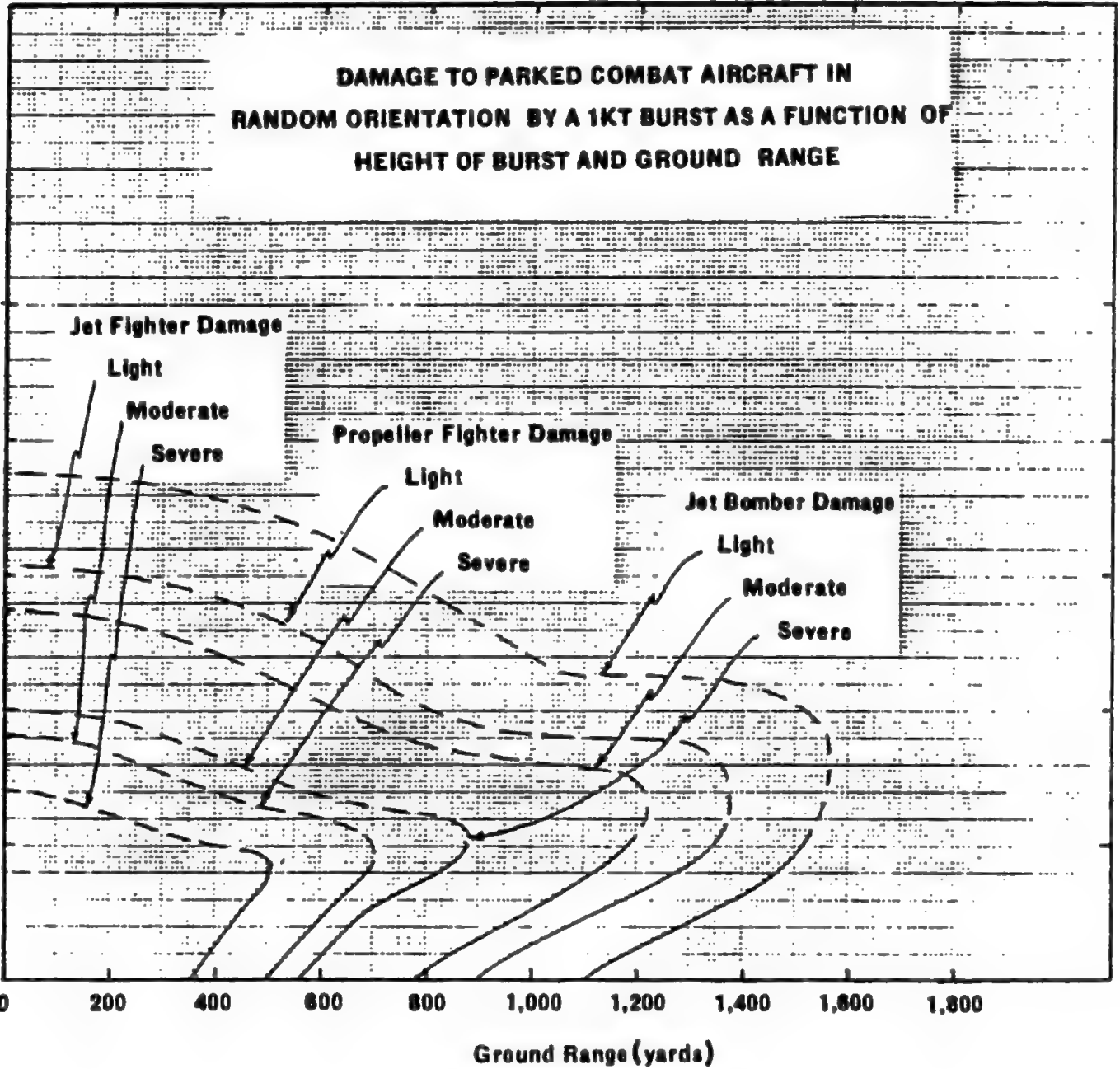

DAMAGE TO PARKED COMBAT AIRCRAFT, NOSE-ON ORIENTATION

Figure 9-3 presents height of burst vs. ground range curves for light, moderate and severe damage to bomber and fighter aircraft for nose-on orientation. These curves are drawn for 1 KT and are based on the following definitions of damage and corresponding peak overpressure criteria.

Light Damage—That damage which does not prevent flight of the aircraft, though performance may be restricted thereby. Jet bombers, 2 psi; propeller fighters, 2 psi; jet fighters, 3 psi.

Moderate Damage—That damage which requires field maintenance to restore the aircraft to operational status. Jet bombers, 3 psi; propeller fighters, 5 psi; jet fighters, 7 psi.

Severe Damage—That damage which requires depot level maintenance to restore the aircraft to operational status. Jet bombers, 5 psi; propeller fighters, 7 psi; jet fighters, 9 psi.

Scaling. Height of burst and ground range for a given degree of damage scale as the cube root of the yield—

$$\frac{h_1}{h_2} = \frac{d_1}{d_2} = \frac{W_1^{1/3}}{W_2^{1/3}}$$

where h_1 and d_1 are height of burst and ground distance for yield W_1 , and h_2 and d_2 are the corresponding height of burst and distance for yield W_2 .

Example.

Given: A 30 KT weapon is burst 4,000 feet above the terrain and a horizontal distance of 2,500 yards from a jet bomber parked nose-on to the burst.

Find: The corresponding 1 KT height of burst and the degree of damage to be expected.

Solution: The corresponding 1 KT height of burst is $\frac{4,000}{(30)^{1/3}} = 1,290$ feet.

The corresponding distance from ground zero is $\frac{2,500}{(30)^{1/3}} = 800$ yards.

From figure 9-3, moderate to severe damage would be expected at 2,500 yards from ground zero for a 30 KT weapon burst 4,000 feet above the terrain.

Answer.

Reliability. These curves are based on full scale test data for military bomber and fighter aircraft and detailed analysis of weapons effects on basic structural components. It is considered that they represent the best available estimates, for the aircraft types specified, of distances at which 50 percent of the aircraft parked at that range may be expected to be damaged to the degree specified.

Related Material.

See paragraph 9.2.

See also figures 9-1 and 9-2.

ESTIMATES OF GUSTS AND THERMAL ENVELOPES FOR TYPICAL COMBAT AIRCRAFT

Figure 9-4 presents an estimate, for each of three typical combat aircraft types, of the lethal envelope in the vertical plane containing the flight path. For each diagram, the silhouette represents the position of the aircraft at burst time; a 1 KT burst anywhere within the envelope is expected to destroy the aircraft. The corresponding lethal volume is approximately that within the surface of revolution generated by revolving the envelope shown about the flight path axis. Also indicated on the diagrams are the ranges at which the radiant exposure of the aircraft would be 135 cal/cm^2 , an exposure level at which most aircraft would

experience some melting of skin panels by thermal radiation from a 1 KT burst.

Scaling and Reliability. Estimates of lethal envelopes for other yields may be made by scaling the ranges to the blast envelopes by the cube root of the yield and the ranges for the 135 cal/cm^2 envelopes by the square root of the yield. The diagrams are presented to illustrate general shapes and sizes of lethal envelopes for aircraft and it is not intended that the numerical data be applied directly to any specific aircraft models.

Related Material.

See paragraph 9.3.

ESTIMATES OF GUSTS & THERMAL ENVELOPES FOR TYPICAL COMBAT AIRCRAFT

1 KT ANTI-AIRCRAFT BURST

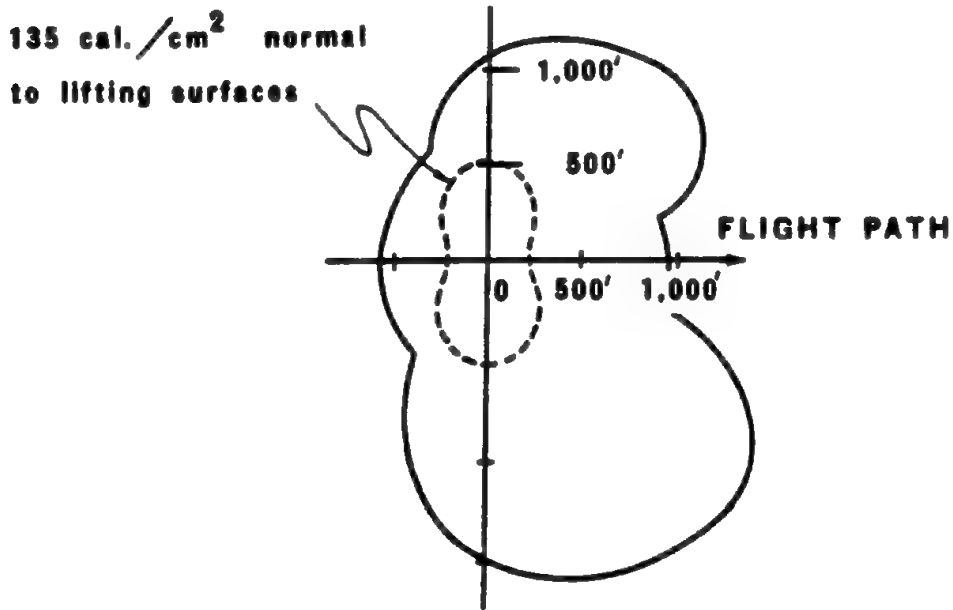

SUBSONIC BOMBER
 ALTITUDE 40,000'
 SPEED, MACH .9

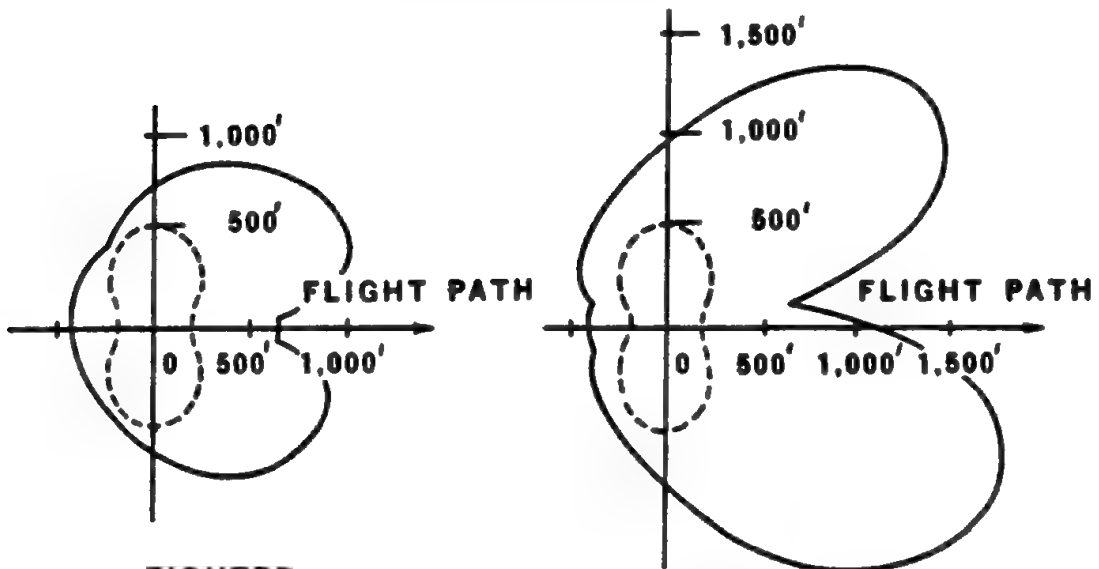

FIGHTER
 ALTITUDE 40,000'
 SPEED, MACH .95

SUPERSONIC BOMBER
 ALTITUDE 70,000'
 SPEED, MACH 2.5

SECTION XI

FOREST STANDS

11.1 General

Although forests or tree stands may afford troops deployed therein significant protection against certain effects of nuclear weapon detonations (e. g. thermal radiation), the forests themselves are quite vulnerable to some of these effects. Falling limbs and trees create a missile hazard and the resultant debris on the forest floor may impede the movement of troops and most vehicles. In dry, windy weather, forest fires may be initiated by a nuclear weapon detonation, with smoke and flame extending the range of hazardous effects from the bomb itself many times. Forest vulnerability depends on recent local weather history and upon the type of tree stand involved. Forest kindling fuels and types of stands are discussed in detail in the paragraphs which follow.

11.2 Air Blast

a. General. For convenience in discussion of blast effects, forest stands are divided into the following types:

(1) *Type I stand: Improved natural or planted conifer forests of European type.* These forests characteristically grow in regular blocks, usually with definite borders. Tree spacing is uniform with only small patches of ground visible through the canopy from above. Trees are of uniform height (100 to 130 feet) and nearly the same in diameter (14 to 24 inches). Stands of this type are vigorous in appearance and fast growing. Viewed from above the crown canopy appears smooth. Within the stand there usually will be found low stumps resulting from thinning, clear lower stems as a result of pruning, and little or no underbrush, combining to give the interior of the stand a clean park-like appearance, and affording good visibility and easy passage into the forest.

(2) *Type II stand: Naturally occurring, unimproved conifer forests that have developed under unfavorable growing conditions.* Unfavorable growing conditions result from: shallow and/or rocky soil, deficient annual rainfall, short growing season with unfavorable temperatures (i. e., higher latitudes and/or higher elevations), and unfavorable topography such as poorly drained flats or steep slopes. Random tree spacing is characteristic, with trees varying in height (10 to 75 feet) and in diameter (1 to 17 inches). The crown canopy generally has an uneven appearance. Large stands often contain bare areas with irregular borders. The stand itself appears low in vigor. The forest floor within the stand is generally cluttered with dead, fallen trees which, when combined with the persistent dead limbs on the dense growing live stems and the heavy underbrush in the numerous stand openings, impede entrance into the stand and decrease visibility.

(3) *Type III stand: All broadleaf forests and naturally occurring, unimproved conifer forests that have developed under favorable growing conditions.* Favorable growing conditions are associated with: deep, generally rock-free soil, adequate annual rainfall, long growing season with favorable temperatures (i. e., middle latitudes and lower elevations), and favorable topography such as well-drained flats and moderate slopes, or along stream courses. Random tree spacing is characteristic with trees varying in height (30 to 120 feet) and in diameter (2 to 25 inches). The crown canopy generally has an uneven appearance. Large stands often contain bare areas with irregular borders. The stand itself appears high in vigor. The forest floor within the stand may be

cluttered with dead, fallen trees which impede entrance into the stand. Underbrush is light or absent, and visibility is fairly good.

b. Air Blast Damage. Height of burst-damage-distance curves for severe and light damage to forests are presented in figures 11-1 to 11-6. Distances to which a given level of damage from a subsurface burst occurs may be derived from figure 7-18 in conjunction with these figures. Examples of scaling accompany figure 11-1. Tree stand types referred to are those given above. Severe and light damage are defined in terms of length of stems down per acre; approximately 1,500 feet per acre for light damage and 9,000 feet per acre for severe damage. These criteria in terms of percentage of trees broken are shown in table 11-1. The approximate number of trees per acre that may be expected for the three stand types is also shown.

Table 11-1. Percentage of Trees Broken for Light and Severe Damage to Forest Stands

Stand type	Total No. of trees per acre	Trees per acre 6 in. or larger in diameter	Light damage, % trees 6 in. or larger in diameter, broken	Severe damage, % trees 6 in. or larger in diameter, broken
I.....	75	75	15	95
II.....	475	260	a 10	a 65
III.....	215	200	b 10	b 60

a Majority of damage as uprooted trees.

b In broadleaf forests majority of damage as branch breakage and uprooting

11.3 Thermal Radiation

a. General. Under certain conditions, the employment of an air burst weapon over a forest or wildland area may cause fires. During the fire season, even when the burning potential (a measure of probable fire aggressiveness) is low, fires may spread. If fires are started in regions of sufficient fuel density when the burning potential is dangerously high, complete evacuation of personnel and equipment may be necessary. Organized control of the spread of the fire is virtually impossible until changes in weather or fuel availability reduce the burning potential.

b. Ignitions. Wildland fuels are generally a mixture of thin and heavy fuel components. Thin fuels are typified by surface litter and grassland; heavy fuels by fallen branches. The thin-

nest fuel present determines the exposure required for ignition of the mixture. Heavy fuels do not ignite and continue to burn by themselves; however, thin fuels may serve as the source of a pilot flame which substantially lowers heavy fuel ignition exposure requirements, or thin fuels may spread fire after the end of the thermal pulse. During the fire season, ignitions may be expected in kindling fuels wherever the radiant exposures exceed 2 to 3 cal/cm² for a 1 KT weapon. As the yield increases the minimum radiant exposures for ignition increase as $W^{1/3}$, i. e., 8 to 10 cal/cm² would be required from a 30 MT weapon to ignite the thinnest wildland fuels. These exposures apply to surfaces normal to the direction of radiation; however, wildland fuels rarely present a flat smooth surface. Individual fuel particles are of many shapes and are oriented more or less at random. Consequently, even at low burst altitudes, minimum ignition exposures can be assumed to remain the same, although a reduced number of ignitions is to be expected owing to the increased shielding effect of trees and shrubs. Green leaves and needles on tree crowns smoke and char but do not ordinarily sustain ignition. This smoke production materially reduces the radiant exposure of the ground surface. Ignitions occur in open areas if the dimensions are large enough so that the area is not completely in the shadow of adjacent timber or brush stands. It is estimated that very few ignitions occur within a timber stand in which the tree canopy shades more than 20 percent of the ground surface. Smoldering ignitions are likely to occur in snags and dead limbs on the forest floor. While such ignitions are not an immediate hazard, they may cause fires to break out up to two or three days later, especially if a large amount of blast breakage occurs, opening the stand to the prevailing winds.

c. Fire Seasons. The fire season of an area is primarily a function of the annual rainfall-temperature pattern and its associated vegetation development, and varies widely between geographic locations. Table 11-2 summarizes these conditions for the more important wildland fuels found throughout the world. Once it is determined that fuel conditions meet those prevailing in the fire season, local weather conditions will determine burning potential.

Table 11-2. Condition of Wildland Fuels During Fire Season

Fuel type	Amount and density of fuel required to constitute a fire hazard	Condition during fire season
Grass or heath... Grassland; dry bracken ferns and other seasonal plants; dry re-growth in previously burned areas.	Uniform grass cover one-half ton or more per acre.	Vegetation nearly cured or dead.
Evergreen brush... Perennial evergreen shrubs and brush; chaparral; young ever-green growth.	75 percent or more area covered.	15-25 percent by weight of leaves and associated twigs dead.
Deciduous broad-leaf forest. Forest predominantly of trees such as oak, birch, maple, etc., leaves of which die and fall every year.	Ground covered with more or less continuous layer of dead leaves.	Leaves off trees; ground vege-tation dead or nonexistent.
Coniferous forest. Forest of evergreen pines, firs, spruces, etc.; generally the family of needle bearing trees.	Ground covered with more or less continuous layer of dead needles and twigs.	Needles and twigs dry enough to break easily when bent. Grass and other ground vegetation, if present, curing or dead.

d. Kindling Fuels. The majority of thin wild-land fuels which serve as kindling material are typed as shown in table 11-3 into four classes corresponding to different minimum exposures required for ignition. Ignition exposures required increase as fuel moisture content increases. Since ignition generally occurs on those surfaces most exposed to the atmosphere, required ignition exposures are a function of relative humidity as shown in figure 11-7. Fires may be blown out by the blast wave, depending on the time interval between ignition and arrival of the shock. Blow-out is not expected in overpressure regions below 5 psi for fully exposed fuels. When fires are not blown out, they generally increase in intensity due to action of the blast wind.

Table 11-3. Classes of Thin Wildland Kindling Fuels (Arranged in Order of Decreasing Flammability)

Class	Description
I.....	Broadleaf and coniferous litter—mixture of fine grass, broken leaves and duff, and thin translucent broadleaf leaves.
II.....	Hardwood and softwood punk in various stages of decay.
III.....	Cured or dead grass.
IV.....	Conifer needles and thick, nearly opaque broadleaf leaves.

e. Burning Potential. The principal factors, aside from the fuels present, that influence the burning potential of a forest or wildland area are—the nature of the terrain, the wind speed close to the ground, the relative humidity and the precipitation history. An approximate guide for evaluating the effects of weather on burning potential is given in table 11-4. Fuels seldom burn vigorously, regardless of wind conditions, when the fuel moisture is greater than 16 percent. This corresponds to an equilibrium moisture content for 80 percent relative humidity. About a quarter inch of rain renders fuels temporarily nonflammable and may extinguish going fires in thin fuels. The time required to restore the burning potential to the value prior to the rain may vary from hours to days depending on local weather conditions. Surface fuels in the interior of timber stands are exposed to reduced wind velocities and generally have high fuel moisture due to shading by the canopy.

f. Fire Spread. Under identical weather conditions, concentrations of heavy fuel are more hazardous than thin fuels, even though they tend to reduce local wind speeds and do not respond as rapidly to changes in relative humidity. Trees and heavy limbs on the forest floor may be ignited by an otherwise nonhazardous surface fire. When heavy fuels are present near the borders of standing timber, fire may travel into the tree crowns and continue to crown (spread

Table 11-4. Burning Potential for Light Wildland Fuels During Fire Season (Terrain With Slopes Less Than 20 Percent)

Wind speed at 20 feet above ground in the open	Relative humidity (percent)			
	Below 15	15-40	40-65	65-80
Below 5 knots.....	Dangerous*.....	Dangerous.....	Low*.....	Low.
5-10 knots.....	Critical*.....	Dangerous.....	Dangerous.....	Low.
10-15 knots.....	Critical.....	Critical.....	Dangerous.....	Low.
Above 15 knots.....	Critical.....	Critical.....	Critical.....	Dangerous.

***Definitions:**

Low—irregular fire perimeter, spread greatly affected by local changes in fuel structure and topography, depth of fire small. Fire generally stops at roads and ridge tops. Control action can be on an individual basis.

Dangerous—continuous intense fire front which moves rapidly, frequently spots ahead. Aggressive organized action required to protect personnel and equipment.

Critical—conflagration-type fire, in heavy fuels readily crowns and spots as much as a mile ahead. Requires personnel and equipment to be evacuated from in front and from near the flanks of such fires. Control action effective only when changes in fuel type or burning conditions permit.

Note 1. For heavy fuels, use the classification for the next higher wind speed.

Note 2. For terrain with slopes greater than 20 percent, use the classification for the next higher wind speed.

Note 3. For canopy shading 20 percent of the ground, reduce wind one class and increase relative humidity one class.

Note 4. For full shading, reduce wind two classes and increase relative humidity two classes.

from top to top) even though ground fuel concentrations are low. Pine species are most likely to crown, fir and spruce less likely, and hardwoods least likely. Where large areas of heavy dry fuels are ignited simultaneously, a large whirling fire may develop. Such fires exhibit erratic spread behavior. Whirls may break off the main fire

and travel against the prevailing wind. Whenever a strong upward convection column is built up in the case of a heavy fuel fire, the fire may spread very rapidly by "spotting", i. e., by throwing firebrands. Fires started by spotting may travel toward the main fire due to strong in-drafts.

MINIMUM RADIANT EXPOSURE FOR IGNITION OF WILDLAND KINDLING FUELS BY CLASS SCALED TO 1KT

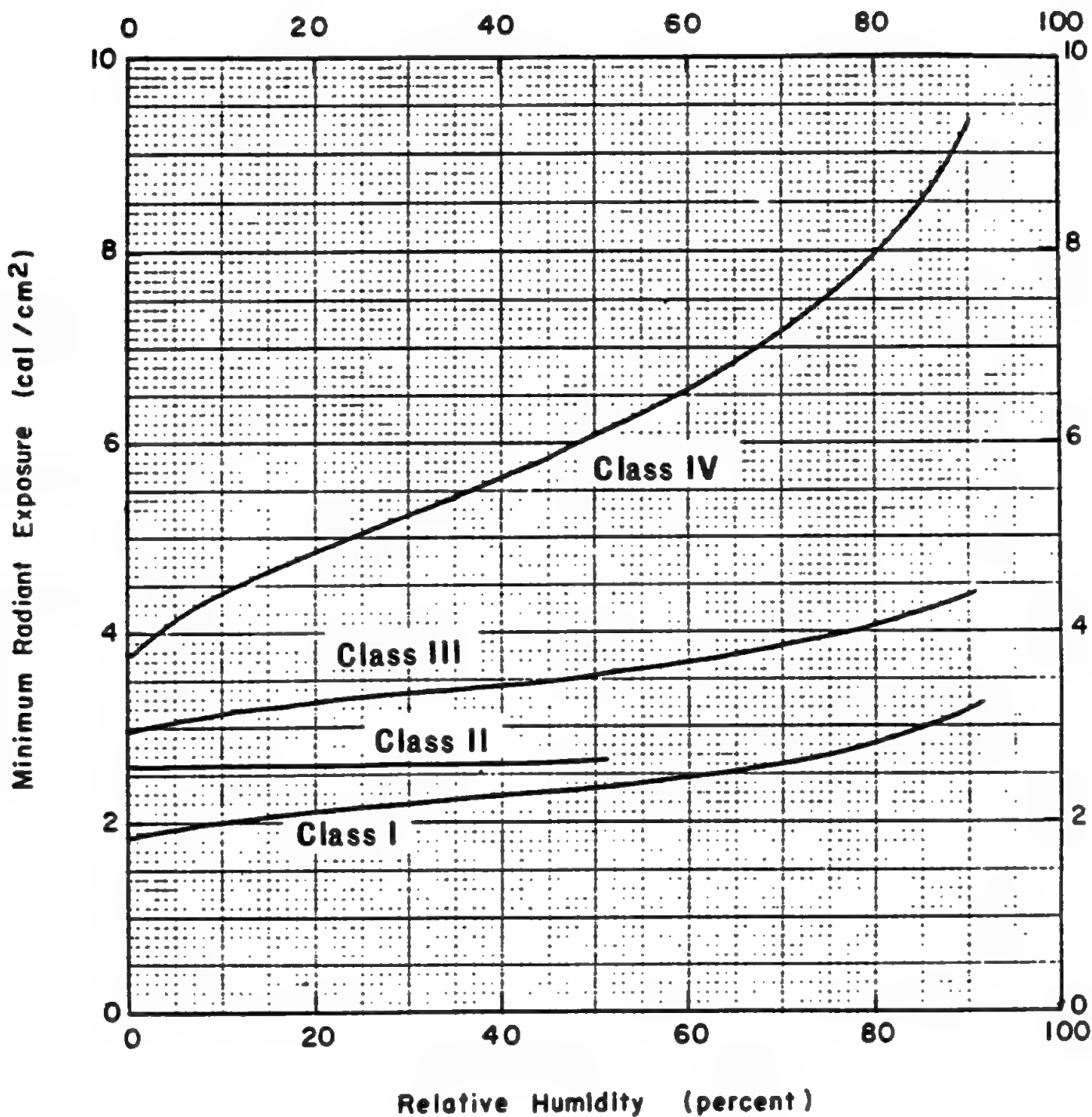

SECTION XII

MISCELLANEOUS RADIATION DAMAGE CRITERIA

12.1 Fire in Urban Areas

a. General. The employment of an air burst weapon over urban areas may produce, in addition to blast damage, mass fires which under proper conditions materially increase the degree and extent of damage. The behavior of such fires, whether they are of primary or secondary origin, follows the pattern of fires in forest and wildland areas. The burning potential for urban areas varies with weather conditions in much the same manner as for wildlands; however, the fire season as such is not as pronounced as in wildlands. During those seasons when weather conditions may reduce exterior potentials to zero, dwellings are usually heated, so that interior fuels are dried out. Fire incidence and subsequent fire buildup depend also upon the amount and distribution of flammable material used in interior furnishing and building construction, the incidence of interior kindling fuels, and the relative cleanliness of the living habits of the population.

b. Ignition Points. A survey of metropolitan areas in the United States indicates that the incidence of exterior ignition points can be correlated with urban land use. Table 12-1 presents a relative tabulation based on exterior kindling fuels. Newspapers and other paper products account for 70 percent of the total, while dry grass and leaves account for another 10 percent in residential areas. Most other exterior kindling fuels are present in small percentages or require radiant exposures in excess of 10 cal/cm² for ignition. Weathered and badly checked fences and building exteriors which contain appreciable dry rot constitute an ignition hazard. The tabulation presented in table 12-1 is not representative of European cities and other areas where fuel is at a premium or where extensive use is made of stone, brick, masonry, and heavy timber construction. Multi-story buildings and narrow streets reduce both interior and exterior primary ignitions, since such ignitions are proportional to the amount of sky seen from the location of the probable ignition point.

Table 12-1. Relative Incidence of Ignitions in Metropolitan Areas of the United States by Land Use (Based on Exterior Kindling Fuels)

Land use	Relative Incidence
Downtown retail.....	1. 0
Large manufacturing*.....	1. 4
Good residential.....	1. 6
Small manufacturing.....	3. 8
Poor residential.....	5. 2
Neighborhood retail.....	5. 5
Waterfront areas.....	8. 0
Slum residential.....	11. 7
Wholesale.....	15. 1

*May be likened to a typical fixed military installation in the Z. I.

c. Humidity Effects. Since paper is the major exterior kindling fuel and is also an important interior fuel, the extent of ignitions may be estimated from the minimum radiant exposure requirements for this material (fig. 12-1). Thin exterior kindling fuels respond to hourly changes in relative humidity; however, fire buildup and subsequent fire behavior are best estimated from the average daytime relative humidity. Maximum fire effects occur during daily periods of lowest relative humidity, usually mid-afternoon. Guides for estimating urban burning potentials are given in figures 12-2 and 12-3. Where central heating of dwellings is a common practice, interiors are much drier than would be indicated by exterior relative humidities and temperatures. Based on United States experience, interior heating becomes an important factor when the maximum daily temperature drops below 70° F. Where fuel is scarce or expensive, this temperature may drop to 60° F., or even lower.

d. Fire Spread. The rate of fire buildup in urban areas is expected to be slower than for wildlands. The time to maximum fire intensity is less for the relatively high ignition incidence areas of table 12-1 than for those of lower ignition incidence. Aside from weather conditions, the principal factors which influence fire spread are the continuity, size and combustibility of buildings, fuel value of building contents, and

topography. When strong convective action develops and spotting is frequent, the flammability of roof material is an important factor in spread. Spread of the fire front generally occurs by radiation from adjacent buildings; hence, fire stops only when the building spacing becomes great enough to reduce this radiation level below a critical value. This critical spacing is greater for multi-story buildings and varies with building combustibility, but on the average is about 50 to 100 feet.

12.2 Nuclear Radiation Damage

a. Neutron Irradiation.

- (1) *Free air neutron flux.* The curves in figure 12-4 show the number of fast neutrons per square centimeter expected per kiloton of yield at various horizontal distances from typical airburst fission weapons detonated at altitudes up to 100,000 feet MSL. It is believed that these curves will give results correct within a factor of five.
- (2) *Permanent damage.* Except for photographic film, which is clouded by neutron interaction with particles in the emulsion, and for electronic equipment which utilizes transistors, no permanent damage to equipment results from neutron irradiation. There is evidence that exposure to a neutron flux in excess of 10^{11} neutrons per square centimeter permanently alters the characteristics of transistors. However, any electronic equipment exposed to this flux of neutrons from a nuclear weapon detonation is likely to be severely damaged or destroyed by other effects. Discoloration of glass by neutrons does not occur for fluxes less than about 10^{18} neutrons per square centimeter, and thus can be disregarded as a significant effect.
- (3) *Induced activity.* If the neutron flux is sufficiently high, a certain amount of neutron induced gamma activity results for most articles made of steel, due to the manganese which is usually present in commercial steels. The induced activity presents no personnel hazard except for articles exposed within or almost within the fireball, and even then the activity

decays so rapidly as to be negligible less than a day after exposure. Significant neutron induced beta activity results in articles made of brass or other copper alloys, if exposed in or near the fireball. The personnel hazard is negligible unless the articles are handled very soon after the detonation. Radioactive decay reduces the activity to negligible levels within a few days.

b. *Gamma Radiation.* In general, massive quantities of gamma radiation are required to produce any damage to materials, so that damage by some other weapon phenomenon is nearly always more significant. Gamma radiation in excess of 10,000 roentgens can cause deterioration of rubber and other polymers as evidenced by a decrease in breaking strength. Exposure of glass to very high quantities of gamma radiation can produce discoloration. The intensity of radiation required is so great that this may be disregarded as a significant effect. Gamma rays, unlike neutrons, induce negligible radioactivity in materials; therefore, no residual radiation hazard is caused by initial gamma radiation.

c. *Electromagnetic Radiation.* A large electrical signal is produced by a nuclear weapon detonation. The signal consists of a rather sharp transient signal with a strong frequency component in the neighborhood of 15 kilocycles. Field strengths greater than 1 volt per meter have been detected from megaton yield weapons at a distance of about 2,000 miles. Electronic equipment which responds to rapid, short duration transients can be expected to be actuated by pickup of this electrical noise.

12.3 Thermal Damage to Various Materials

In table 12-2 the critical radiant exposures for specified damage to various materials are shown for three weapon yields. The values presented for fabrics apply for an ambient relative humidity of 65 percent and an ambient temperature of 20° C. For extremely dry conditions the values shown for fabrics should be reduced by 20 percent. For extremely high relative humidities, near 100 percent (at 20° C), the values for fabrics should be increased by 25 percent. If the fabrics are watersoaked, the critical radiant exposures should be increased by 300 percent.

Table 12-2. Critical Radiant Exposure Values for Various Materials

Uniforms	Color	Weight (oz./yd ²)	Damage	Critical radiant exposure Q _c . (cal./sq. cm)		
				1 KT	100 KT	10 MT
<i>Army</i>						
Cotton twill (fatigue).....	Green.....	8	{ Scorchd.....	3	5	9
			{ Destroyed.....	8	14	25
Wool serge (winter service).....	OD.....	9	{ Scorchd.....	3	6	10
			{ Destroyed.....	21	37	66
Wool flannel.....	OD.....	11	{ Scorchd.....	3	5	8
			{ Destroyed.....	20	40	70
Wool tropical worsted.....	Khaki.....	11	{ Scorchd.....	6	9	13
			{ Destroyed.....	13	20	30
Cotton twill shirt and trousers (summer).....	Khaki.....	6	{ Scorchd.....	4	6	11
			{ Destroyed.....	18	31	56
<i>Navy</i>						
Cotton twill (working).....	Khaki.....	8	{ Scorchd.....	3	5	8
			{ Destroyed.....	15	26	46
Cotton denim (dungaree).....	Blue.....	9	{ Nap Scorchd.....	6	10	17
			{ Destroyed.....	7	13	23
Cotton chambray shirting (working).....	Blue.....	3	{ Scorchd.....	3	6	11
			{ Destroyed.....	7	13	22
Cotton twill (white uniform).....	White.....	8	{ Scorchd.....	4	8	14
			{ Destroyed.....	34	60	109
Wool, Melton, (dress blues).....	Blue.....	16	{ Scorchd.....	1	16	13
			{ Destroyed.....	9	18	28
Wool, Kersey (overcoat).....	Blue.....	30	{ Scorchd.....	1	2	3
			{ Destroyed.....	37	65	110
Wool, serge (officer's uniform).....	Blue.....	14	{ Scorchd.....	5	9	16
			{ Destroyed.....	11	21	37
Wool, tropical worsted (officer's uniform).....	Khaki.....	11	{ Scorchd.....	5	9	16
			{ Destroyed.....	11	20	37
Vinyl resin, combined (rain).....	Black.....	13	{ Scorchd.....	1	1	2
			{ Destroyed.....	5	6	8
<i>Marine Corps</i>						
Cotton poplin shirting.....	OD.....	6	{ Scorchd.....	3	6	10
			{ Destroyed.....	10	18	32
Wool elastique (winter).....	Green.....	16	{ Scorchd.....	2	4	7
			{ Destroyed.....	25	45	80
		21	{ Scorchd.....	5	8	15
			{ Destroyed.....	30	54	95
Wool, Kersey (winter).....	Green.....	16	{ Scorchd.....	2	2	6
			{ Destroyed.....	27	48	85
Wool serge.....	Green.....	12	{ Scorchd.....	2	3	6
			{ Destroyed.....	16	28	50
<i>Air Force</i>						
Cotton twill shirt (tropical).....	Khaki.....	5	{ Scorchd.....	6	10	19
			{ Destroyed.....	9	15	27
Wool gabardine shirt.....	Gray.....	8	{ Scorchd.....	10	17	28
			{ Destroyed.....	14	22	37
Wool gabardine shirt.....	Blue.....	8	{ Scorchd.....	1	2	4
			{ Destroyed.....	8	14	25
Nylon—flying jacket.....	OD.....	5	{ Scorchd.....	2	3	6
			{ Destroyed.....	7	13	23

Table 12-2. Critical Radiant Exposure Values for Various Materials—Continued

Material	Damage	Critical radiant exposure Q_c (cal/sq cm)		
		1 KT	100 KT	10 MT
Tent material:				
Canvas, white, 12 oz/yd ² , untreated.....	Destroyed.....	12	21	37
Canvas, OD, 12 oz/yd ² , flame-proofed.....	Destroyed.....	5	9	17
Packaging materials:				
Fibreboard, V2S, BT 350 psi, laminated.....	Flames during exposure.....	9	16	29
Fibreboard, V3S, BT 275 psi, laminated.....	Flames during exposure.....	7	13	23
Fibreboard, V3C, BT 350 psi, corrugated.....	Flames during exposure.....	6	11	19
Fibreboard, W5C, BT 200 psi, corrugated.....	Flames during exposure.....	5	10	18
Plywood, douglas fir (3/4 in.).....	Flames during exposure.....	9	16	20
Airship material, aluminized, N-113A100, 16 oz/yd ²	{ Aluminum surface discolored.....	20	35	61
	{ Aluminum surface destroyed.....	24	43	75
	{ Fabric destroyed.....	27	47	82
Airship material, aluminized, N-113A70, 19.4 oz/yd ²	{ Aluminum surface discolored.....	10	18	31
	{ Aluminum surface destroyed.....	15	27	44
	{ Fabric destroyed.....	20	35	61
Airship material, aluminized, N-128A170, 8 oz/yd ²	{ Delaminates.....	2	4	7
	{ Fabric destroyed.....	5	10	17
Doped fabrics (used on some aircraft control surfaces):				
Cellulose nitrate covered with 0.0015" thick aluminum foil.....	Sporadic flaming.....	60	80	140
Cellulose nitrate, aluminized.....	Persistent flaming.....	5	6	10
Plastics:				
Laminated methyl methacrylate.....	Surface melts.....	73	120	230
USAF window plastic (1/2 in.).....	Bubbling.....	240	430	750
Vinylite (opaque), 1/2 in. thick.....	{ Dense smoking.....	3	4	6
	{ Flaming.....	20	20	25
Sand:				
Coral.....	Explosion*.....	15	27	47
Siliceous.....	Explosion*.....	11	19	35
Sandbags: Cotton canvas, dry, filled.....	Failure.....	10	18	32
Wood, white pine.....	0.1 mm depth char.....	10	18	32
White pine, given protective coating.....	0.1 mm depth char.....	40	71	126
Construction materials:				
Roll roofing, mineral surface.....	{ Surface melts.....	8	14	25
	{ Flaming during exposure.....	22	40	71
Roll roofing, smooth surface.....	{ Surface melts.....	4	7	12
	{ Flaming during exposure.....	9	16	29

* "Popcornng."

It should be emphasized that the values in table 12-2 for uniforms refer to damage to the material itself and are not applicable for predicting skin burns under uniforms.

The above discussion does not include the damage to materials when they come in contact with or are enveloped by the fireball. The heat input under these conditions is many orders of magnitude higher than the cases just discussed. Several of the variables considered as influential factors in determining the amount of surface material lost by an object exposed within a fireball

include: type of material, surface curvature, orientation, thermal attenuation by the metallic vapors given off by the object, and spallation.

Figures 12-5A and 12-5B give the material loss from spheres of various materials due to ablation or scaling off of the surface material from contact with or envelopment by the fireball. Data for three types of 10-inch diameter spheres are shown; namely, solid steel, solid aluminum, and solid aluminum with small cylindrical wells filled with ceramic inserts. The one curve in figure 12-5A represents all three types.

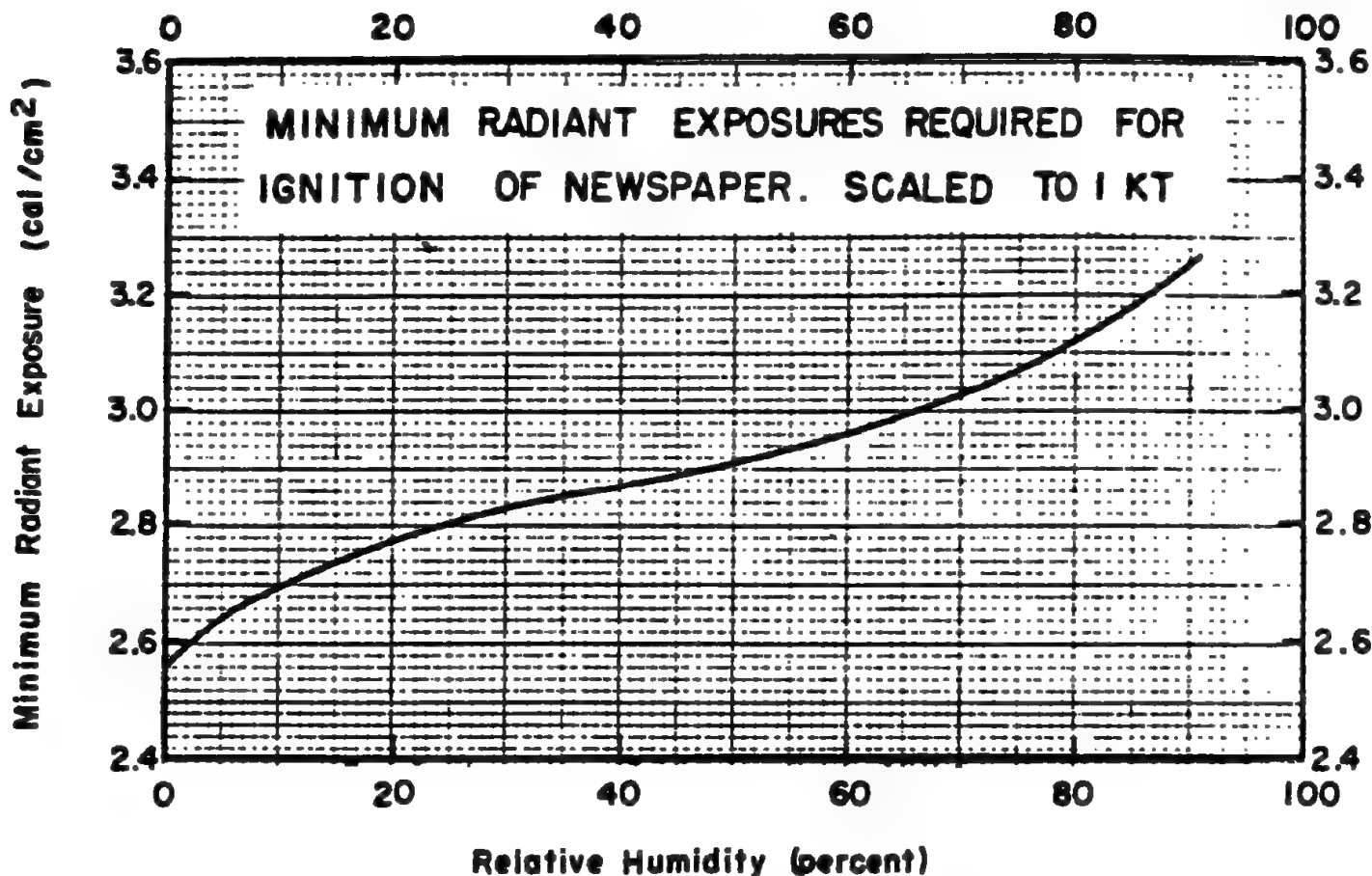

NEWSPAPER IGNITION REQUIREMENTS

Scaling. To find minimum radiant exposures for another yield W at the same relative humidity, multiply the exposures read from figure 12-1 by $W^{1/3}$.

Reliability. Based upon limited empirical data.

Related material.

See paragraphs 12.1b and c.

See also figure 11-1 for radiant exposures required for wildland kindling fuel ignition.

**BURNING POTENTIAL FOR URBAN AREAS
(CENTRAL HEATING NOT IN USE)**

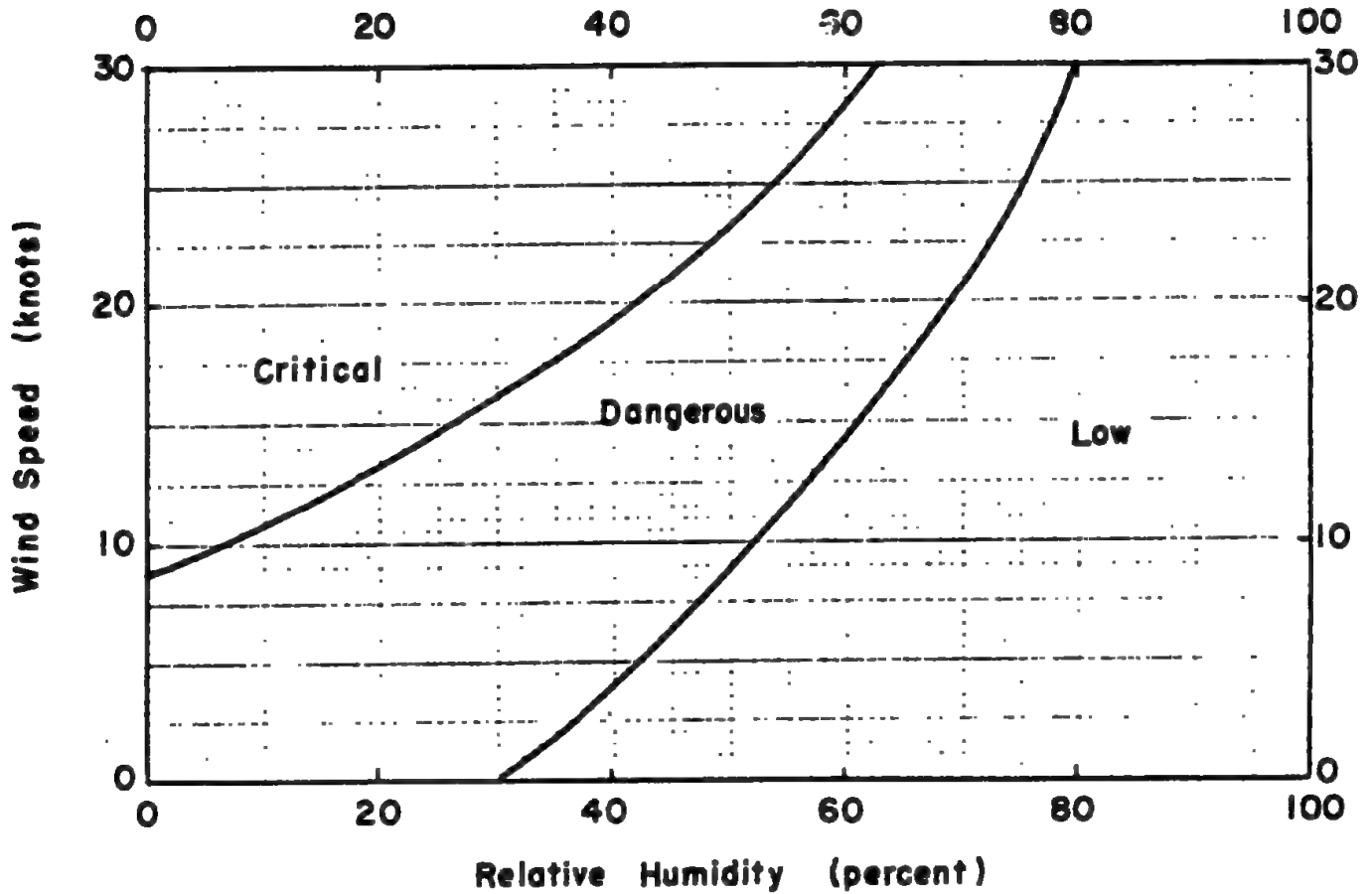

BURNING POTENTIAL FOR URBAN AREAS (CENTRAL HEATING NOT IN USE)

Figure 12-2 represents approximate values of wind speed and average daytime relative humidity conditions corresponding to low, dangerous and critical burning potentials according to the following definitions:

Low. Slow burning fires; fire can be controlled at will. Control action can be on unit structure basis.

Dangerous. Fires burn rapidly; individual building fires combine to form an area fire.

Organized action needed to confine fire to area originally ignited.

Critical. Rapid buildup into conflagration-type fires, high probability of fire storm, spotting frequent and severe. Requires evacuation of fire fighting equipment and personnel; control action effective only at critical breaks in building continuity or density.

Related material.

See paragraphs 12.1c and d.

See also figure 12-3.

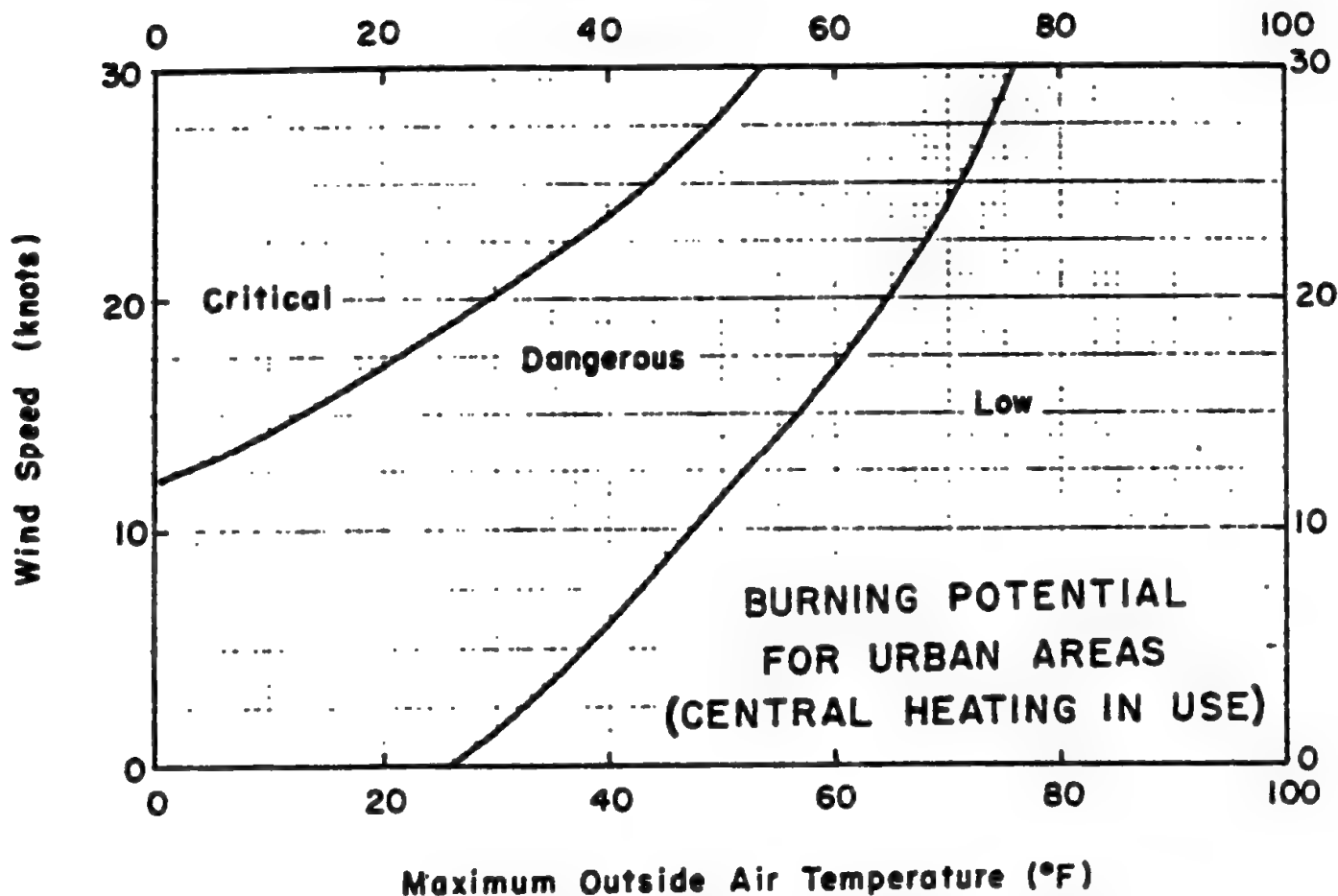

BURNING POTENTIAL FOR URBAN AREAS (CENTRAL HEATING IN USE)

Figure 12-3 shows approximate values of wind speed and maximum outside air temperature conditions corresponding to low, dangerous and critical burning potentials. These burning potentials are defined in the same way as those in figure 12-2.

Note. Temperature must have been below value read on abscissa for at least four consecutive days, with no rain in the previous 24 hours. Snow may be disregarded.

Related material.

See paragraphs 12.1c and d.
See also figure 12-2.

NEUTRON FLUX FOR A TYPICAL FISSION WEAPON

The curves in figure 12-4 show the number of neutrons per square centimeter per kiloton at various horizontal ranges for different heights of burst of typical fission weapons. The curves are for standard atmospheric conditions. Data are presented in AFSWP-1100, published with a higher security classification, from which neutron flux for specific weapons may be computed.

Scaling. At a given horizontal range and altitude, the neutron flux is proportional to the yield of the weapon.

Example.

Given: A 100 KT air burst at 20,000 feet.

Find: The number of neutrons per square centimeter at a horizontal range of 3,400 yards.

Solution: Reading directly from figure 12-4, the neutron flux from a 1 KT weapon is 10^8 neutrons per cm^2 . Since this is a 100 KT burst, 100×10^8 neutrons per $\text{cm}^2 = 10^{10}$ neutrons per square centimeter.

Answer.

Reliability. Neutron flux is dependent upon weapon design. For most fission weapons the curves of figure 12-4 are considered reliable within a factor of 5.

**NEUTRON FLUX FROM TYPICAL FISSION WEAPONS
FOR A 1KT BURST IN A STANDARD ATMOSPHERE
AS A FUNCTION OF BURST ALTITUDE AND HORIZONTAL RANGE**

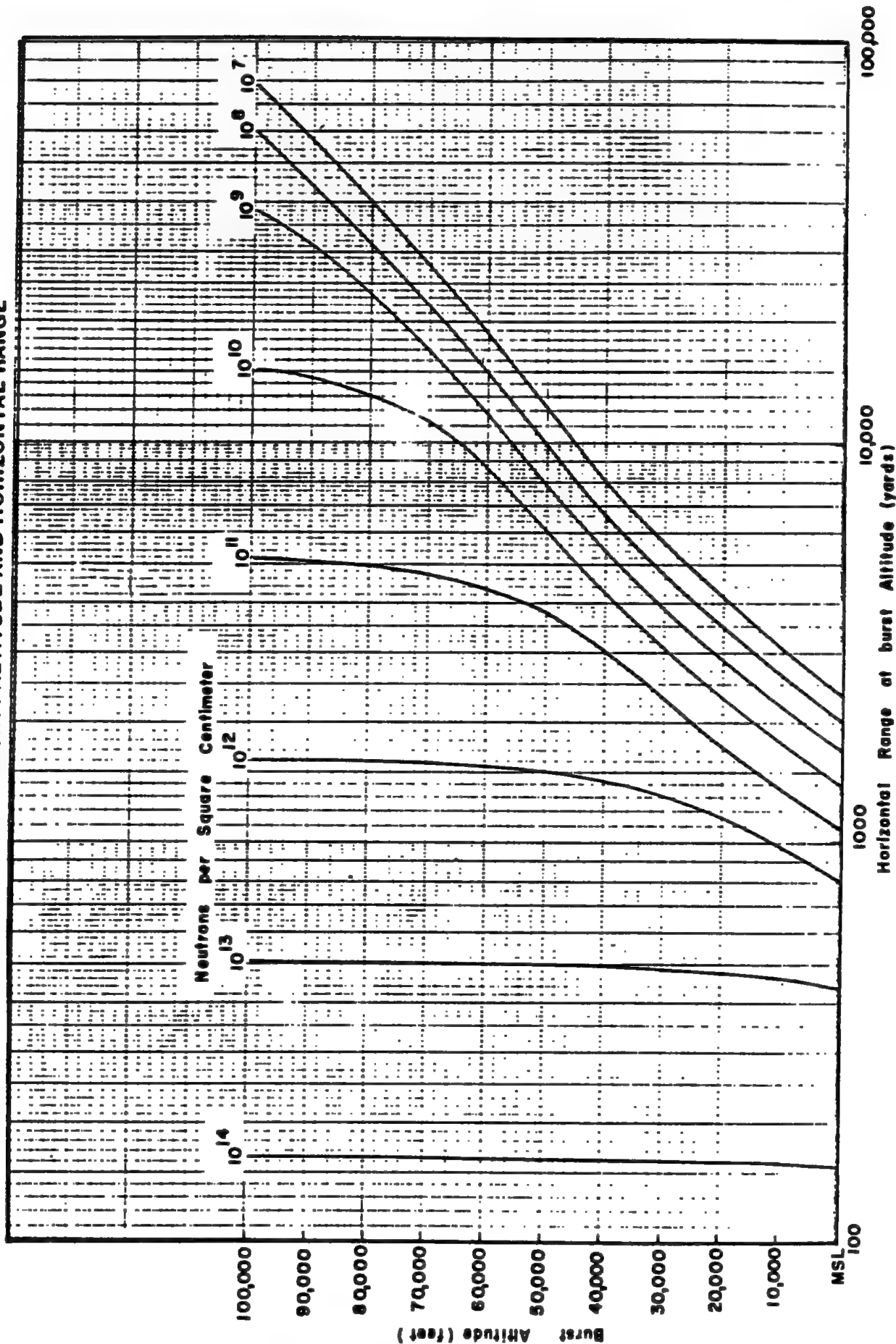

A

**WEIGHT LOSS WITH DISTANCE FROM A 23 KT BURST
FOR ALUMINUM, STEEL, CERAMIC INSERT SPHERES**

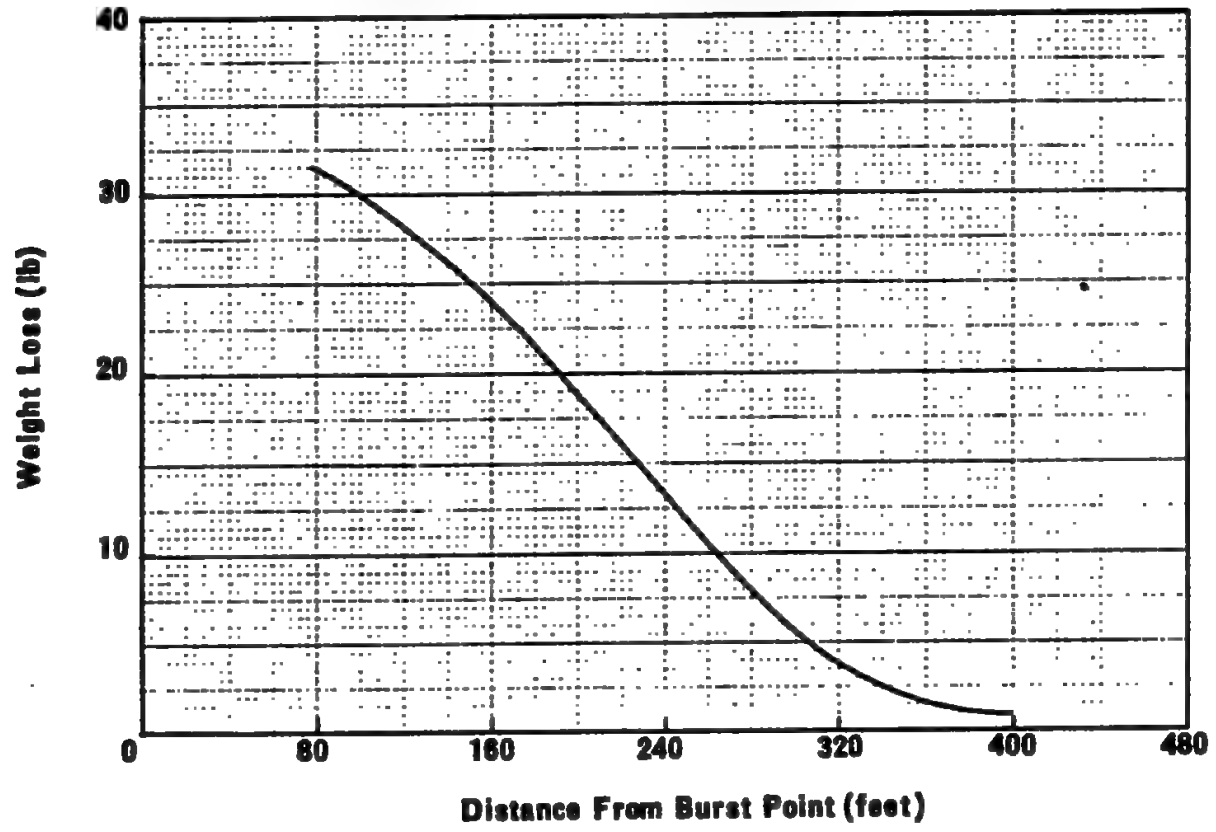

B

**REDUCTION OF SPHERE RADIUS WITH DISTANCE FROM A 23 KT BURST
FOR ALUMINUM, STEEL, CERAMIC INSERT SPHERES**

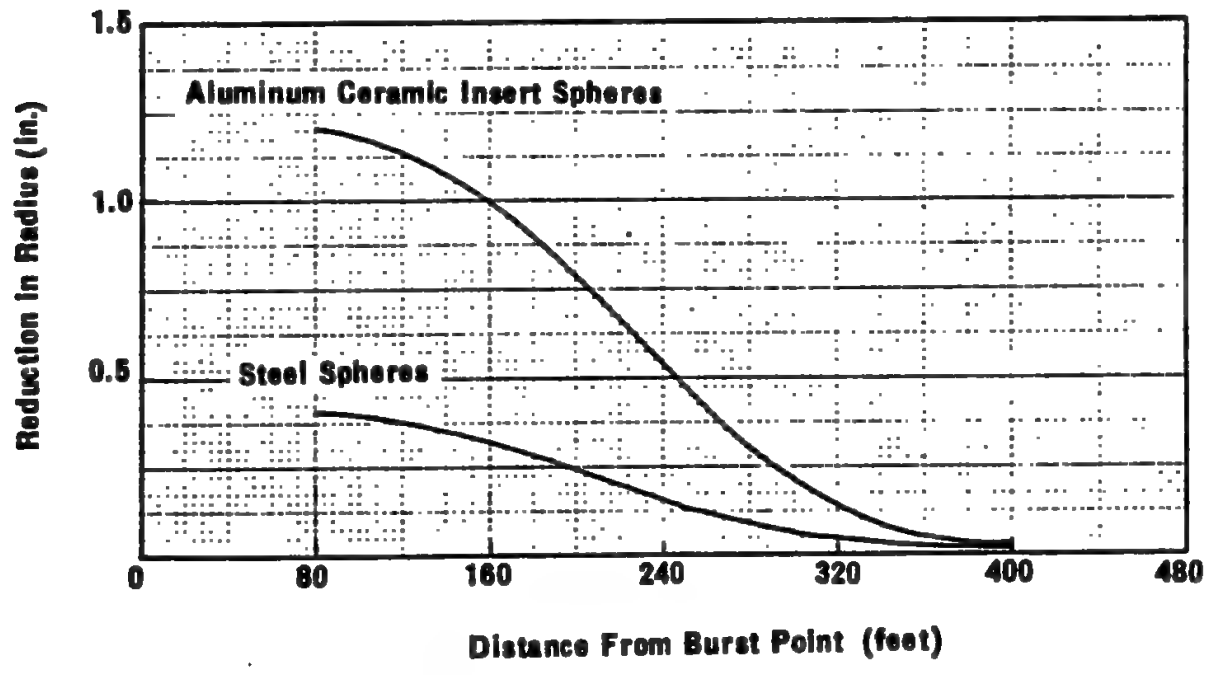

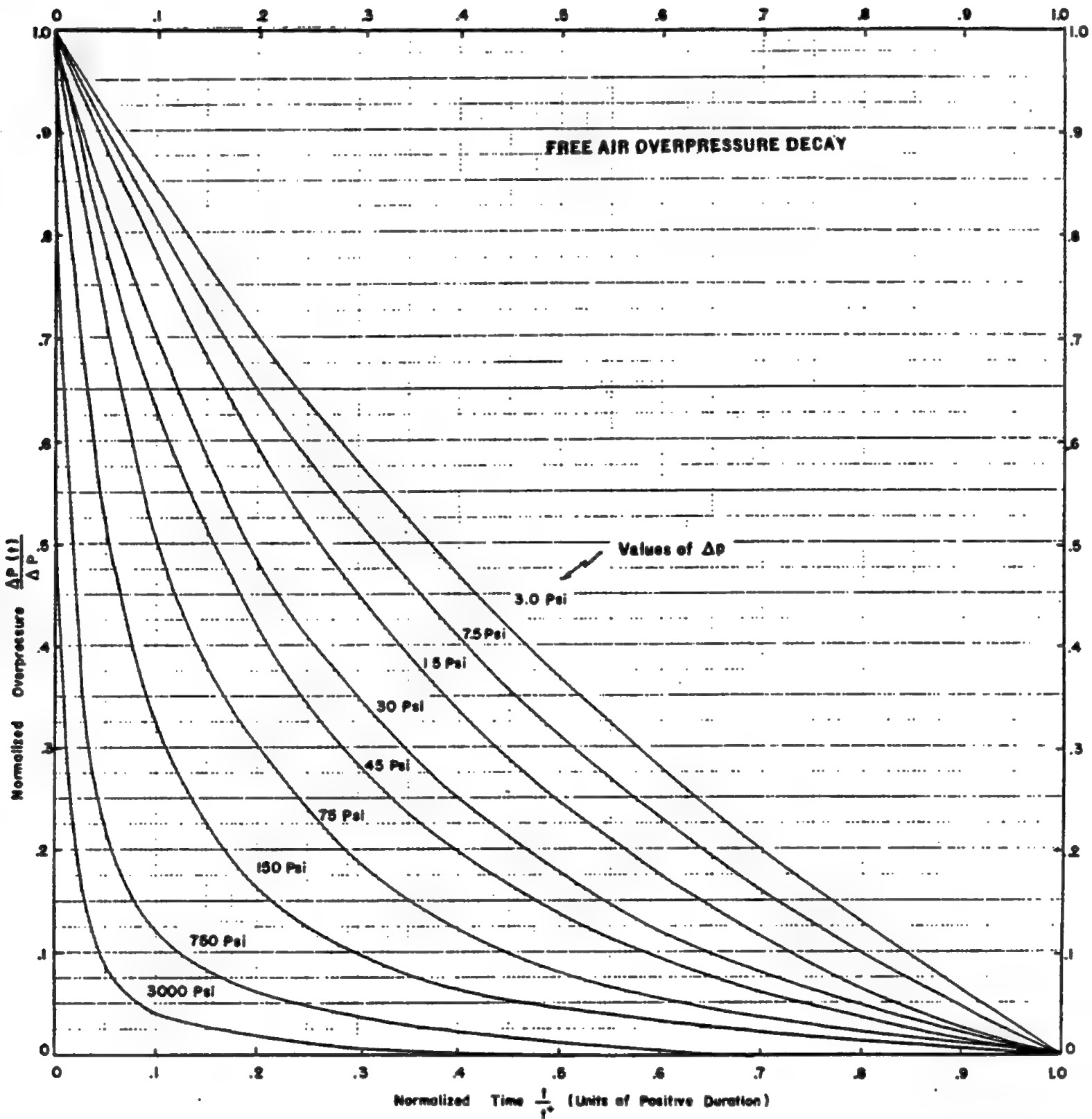

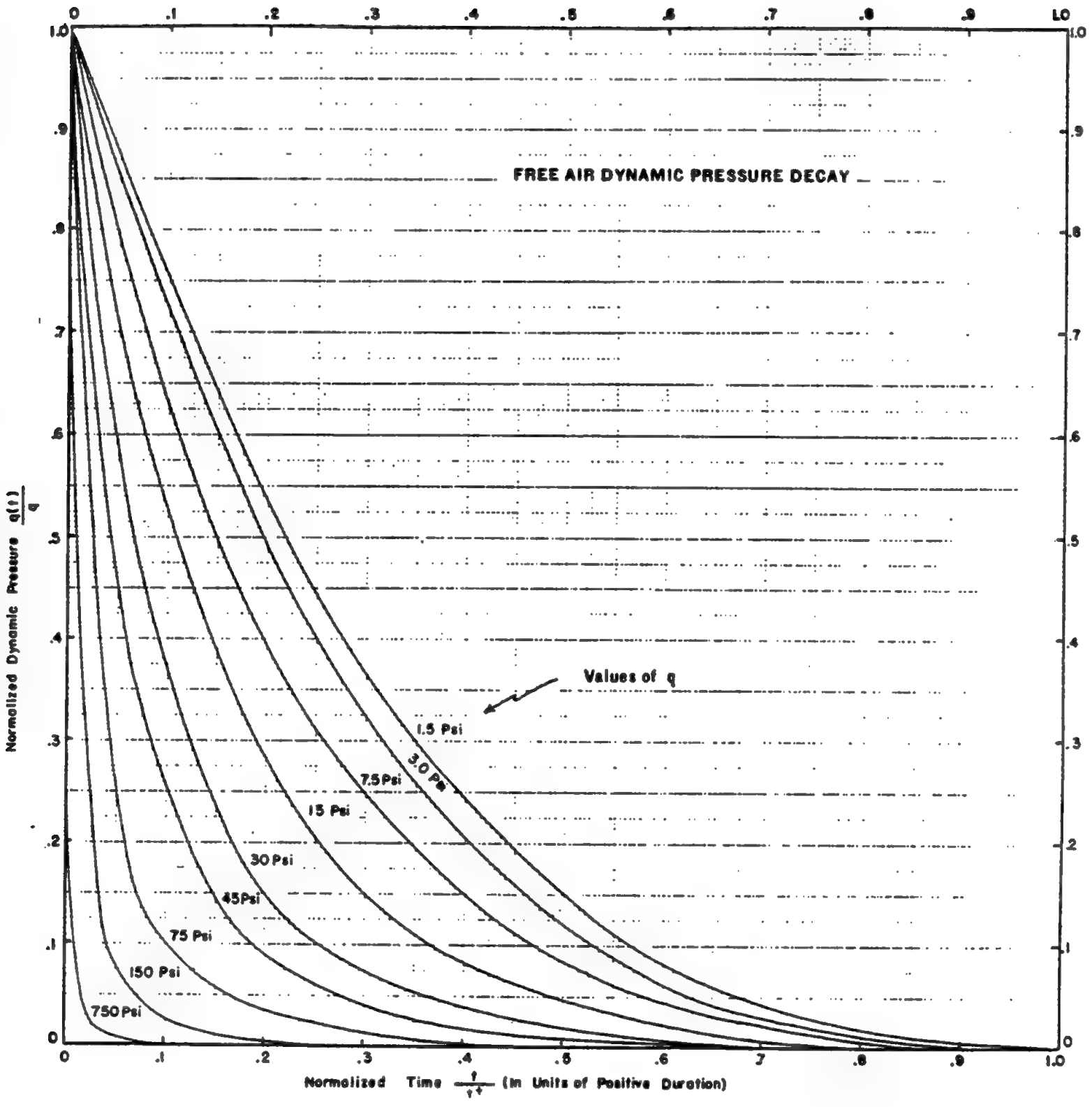

Second radiant power maximum:
For air bursts under 50,000 feet:

$$P_{\max} = 4 W^{1/2} \text{ KT/sec} = 4 W^{1/2} \times 10^{12} \text{ cal/sec (} W \text{ in KT)}$$

Less than 1 percent of the thermal radiation from a nuclear detonation near sea level is emitted before the radiant power minimum.

11.3. Nuclear

1 KT fission yield makes available 300 megacuries of radioactive fission product gamma activity at a time of one hour after a detonation.

1 curie is that quantity of radioactive material which undergoes 3.7×10^{10} disintegrations per second.

The roentgen is a measure of *quantity of ionization*, and is equivalent to:

- 83.8 ergs per gram of air; or
- 1.64×10^{12} ion-pairs per gram of air; or
- 5.24×10^7 Mev per gram of air.

0.7 Mev is the approximate mean effective energy for the gamma rays from a residual fission product field.

To obtain the radiation intensity in roentgens per hour three feet above a plane residual fission product field, multiply the concentration of the contaminant in curies per square foot by 120, or in megacuries per square mile by 4.

Total dose in roentgens accumulated to infinite time from one hour after a burst is numerically equal to five times the dose rate in roentgens per

hour at $H+1$ hour. (Fission product activity.)

The radioactive decay of gross fission products is approximately exponential with time, so that—

$$I = I_1 t^{-1.2}$$

where I is the dose rate at any time t , and I_1 is the dose rate at unit time.

The velocity of a thermal neutron ($E=1/40$ ev) is 2,200 meters per second.

Shielding thicknesses in inches required to cut incident gamma radiation by a factor of ten are:

Material	Initial bomb gamma	Residual gamma
Lead.....	2.1	1.0
Iron.....	4.5	2.8
Concrete.....	18	9.5
Soil.....	26	14
Water.....	41	21

As a rough rule of thumb, the area of effect for a given degree of contamination resulting from a nuclear surface burst can be considered directly proportional to the fission yield of the weapon.

Greatest cloud diameter at 9 minutes after burst time (for kiloton yields) is approximately given by—

$$d = 10,000 W^{1/3} \text{ feet}$$

The dose rate inside the bomb cloud is independent of yield (in the kiloton range) and is given by the formula,

$$D = 1.31 \times 10^5 t^{-2.06} \text{ roentgens per hour,}$$

where t is the time after detonation in minutes.

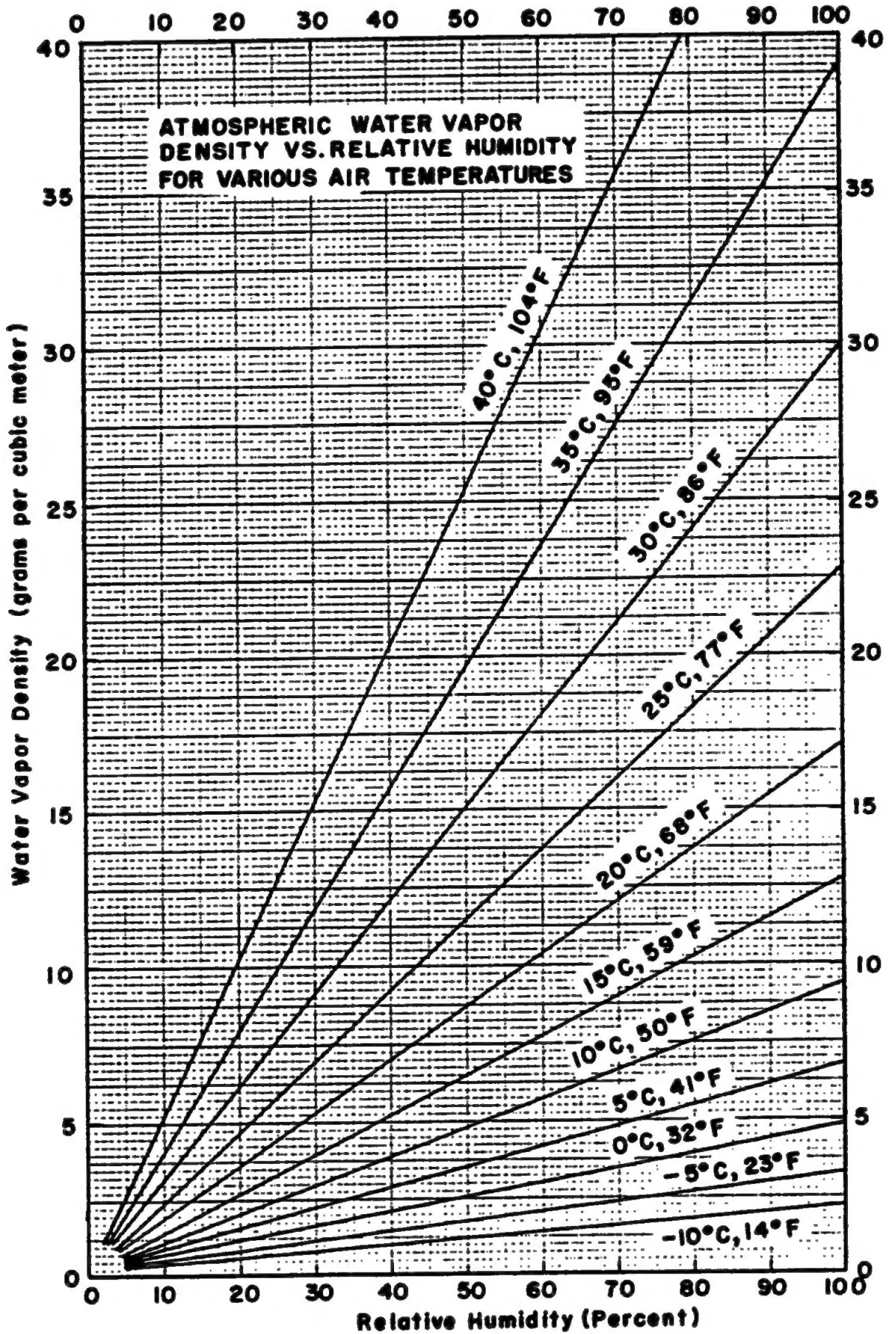

BIBLIOGRAPHY

- The Effects of the Atomic Bomb on Hiroshima, Japan*, Volumes I, II, III (Physical Damage Div. of U. S. Strategic Bombing Survey), May 1947 (U).
- The Effects of the Atomic Bomb on Nagasaki, Japan*, Volumes I, II, III (Physical Damage Div. of U. S. Strategic Bombing Survey), June 1947 (U).
- Convective Heating of Air Above an Inorganic Surface Heated by Radiation from a Nuclear Weapon*, AFSWP-862, F. M. Sauer and W. Lai (For. Serv.), Nov 55 (C).
- Cratering from Atomic Weapons*, AFSWP-514 TAR, W. J. Christensen (AFSWP), 29 Jun 56 (SRD).
- Curves of Atomic Weapons Effects for Various Burst Altitudes (Sea level to 100,000 ft.)*, SC-3282 (TR), Cook and Broyles (SC), 9 Mar 54 (SRD).
- The Effect of Earth Cover in Protecting Structures Against Blast*, AFSWP-357, R. B. Vaile, Jr. (SR1), 30 Sep 54 (CRD).
- The Effect of Rain or Fog on Air Blast*, NAVORD-2944, G. K. Hartmann (NOL), 1 Aug 53 (S).
- Height of Burst for Atomic Weapons*, LA-1665, F. B. Porzel (LASL), May 1954, (SRD).
- Height of Burst for Atomic Bombs*, LA-1406, Francis B. Porzel (LASL), Mar 52 (SRD).
- Height of Burst for Nuclear Weapons*, RM 1107, H. L. Brode (RAND), 1 June 54 (SRD).
- The Interaction of Shock Waves with a Thermal Layer*, Robert Varwig and Jay Zemel (NOL), 18 Jun 55 (OUO).
- Mach Shock Formation from a Nuclear Detonation*, AFSWP-510 TAR, R. J. Hesse and J. R. Kelso (AFSWP), 10 Mar 55 (SRD).
- Operation TEAPOT—Underground Shot Base Surge Analysis*, AFSWP-876, M. L. Milligan and G. A. Young (NOL), 31 Jan 56 (SRD).
- Phenomenology of a High Altitude Atomic Explosion*, SC-3363, Shelton (SC), 28 Apr 54 (SRD).
- The Precursor—Its Formation, Prediction and Effects*, SC-2850 (TR), Frank H. Shelton (SC), 27 Jul 53 (SRD).
- A Preliminary Estimate of the Effect of Fog and Rain on the Peak Shock Pressure from an Atomic Bomb*, AFCD AFSG-16, H. P. Gauvin and J. H. Healy (AFCRC), Sep 52 (SRD).
- Rain, Fog and Cloud Effects on Blast Damage from Atomic Weapons*, SC-3008 (TR), Thomas B. Cook (SC), 22 Oct 53 (SRD).
- The Scaling of Base Surge Phenomena of Shallow Underwater Explosions*, AFSWP-484, M. L. Milligan and G. A. Young (NOL), 1 May 54 (C).
- High Altitude Effects on Blast-Thermal Partition of Energy from Nuclear Explosions, and Associated Scaling Laws*, SC-2969 (TR), F. H. Shelton (SC), 15 Sep 53 (SRD).
- Contamination Patterns at Operation JANGLE*, USNRDL-399, R. K. Laurino and I. G. Poppoff (NRDL), 30 Apr 53 (SRD).
- Gamma-Ray Spectral Measurements of Fall-Out Samples from Operation CASTLE*, AFSWP-822, C. S. Cook (NRDL), 26 Jan 55 (SRD).
- Hazard Due to Beta Radiation from Fission Products Deposited on the Ground After an Atomic Explosion*, CREL-529, F. S. Goulding and G. Cowper, Atomic Energy Commission of Canada, Ltd., Jan 53 (U).

Investigation of Gamma Radiation Hazards Incident to an Underwater Atomic Explosion, W. E. Strobe (BuShips, DN), 1948 (C).

The Nature of Individual Radioactive Particles. I. Surface and Underground ABD Particles from Operation JANGLE, USNRDL-374, C. E. Adams, I. G. Poppoff, and N. R. Wallace (NRDL), 28 Nov 52 (S).

Radioactive Fall-Out Hazards from Surface Bursts of Very High Yield Nuclear Weapons, AFSWP-507, D. C. Borg, L. D. Gates, T. A. Gibson, Jr., and R. W. Paine, Jr. (AFSWP), May 54 (SRD).

The Residual Radiological Hazard from the Air Detonation of an Atomic Weapon in the Rain, AFSWP-501, L. D. Gates, et al. (AFSWP), May 53 (SRD).

Scaling of Contamination Patterns, Surface and Underground Detonations, NRDL-TR-1, C. F. Ksanda, et al. (USNRDL), Sep 53 (SRD).

Prediction of Neutron-Induced Activity in Soils, AFSWP-518, J. F. Canu and P. J. Dolan (AFSWP), 11 Jun 57 (SRD).

The Combined Effects of Thermal Burns and Whole-Body X-Irradiation on Survival Time and Mortality, AFSWP-470, and 473, 474, 475, E. L. Alpen, et al. (NRDL), May, Oct, 53 (U).

Effect of Nuclear Weapon Yield on Effectiveness of Thermal Energy for Burn Production, AFSWP-734, E. L. Alpen (NRDL), 30 Aug 54 (SRD).

Effects of Spectral Distribution of Radiant Energy of Cutaneous Burn Production in Man and Rat, AFSWP-737, E. L. Alpen, et al. (NRDL), 25 Apr 55 (U).

Heat-Reflecting Textiles as Protective Barriers Against Intense Thermal Radiation, AFSWP-849, R. C. Maggio and T. B. Gilhooly (NML), 25 Mar 55 (U).

Reflectance and Absorptance of Human Skin, AFSWP-840, W. Derksen (NML), 31 Mar 55 (U).

Research Report on the Influence of Air Supply and Air Flow on Burns Behind Irradiated Fabrics, AFSWP-1000, W. L. Derksen and J. J. Bates (NML) (U).

The Effect of Earth Cover in Protecting Structures Against Blast, AFSWP-357A, R. B. Vaile, Jr. (SRI), 30 Sep 54 (CRD).

Field Fortifications Test. Exercise Desert Rock VI, Technical Rpt. 1468-TR (ERDL), 2 Nov 56 (SRD).

The Vulnerability of Parked Army Aircraft to Nuclear Detonations, WADC Tech. Rpt. 56-354, D. H. Whitford (WADC), Jun 56 (SRD).

Exercise Desert Rock I (Hq III Corps, Ft McArthur), Oct 51 (SRD).

Report of Test Exercises Desert Rock II and III (Hq Camp Desert Rock), 15 Dec 51 (SRD).

Exercise Desert Rock IV (Hq Sixth Army), Apr-Jun 1956 (SRD).

Exercise Desert Rock V (Hq Camp Desert Rock), Jan-Jun 53 (SRD).

Damage to Field Military Equipment from Nuclear Detonations, AFSWP-511 TAR, R. J. Hesse (AFSWP), 1 Feb 56 (SRD).

Blast Effects on Forest Stands by Nuclear Weapons, AFSWP-971, W. L. Fons, F. M. Sauer, and W. Y. Pong (For. Serv.), 1957 (C).

Distribution of Primary Ignition Points Following Atomic Attack on Urban Targets-Transient Exterior Fuels, AFSWP-412, G. C. Chandler and Keith Arnold (For. Serv.), Mar 53 (U).

Frequency of Urban Building Fires as Related to Daily Weather Conditions, AFSWP-866, A. R. Pirsko (For. Serv.), Mar 56 (U).

A Method for Estimating Probable Ignitions of Interior Fuels by Atomic Weapon Explosion (Survey of Boston and Detroit), AFSWP-340, H. D. Bruce and L. E. Downs (Forest Products Lab), 1 Feb 56 (SRD).

Primary Ignitions Following Atomic Attack on Urban Targets-Transient Exterior Fuels, AFSWP-413, F. M. Sauer, et al. (For. Serv.), Jun 53 (U).

Remarks on Estimation of the Number of Fires Due to the Ignition of Transient Exterior Kindling Fuels, AFSWP-861, F. M. Sauer (For. Serv.), Oct 55 (U).